



一般

型號:	shr811MCX12
產品編號:	F004227
產品系列:	SHR CoaXPress
狀態:	Available

感測器

感測器類型:	Area scan
色度:	Mono
光譜:	Visible
光譜範圍:	400 nm to 1000 nm
解析度:	19,200 × 12,800 (245.80 MP)
感測器型號:	Sony IMX811
感測器架構 (材料):	cmos
快門類型:	rolling-shutter
感測器尺寸:	53.95 × 35.97 mm (64.84 mm, 64.84mm (Type 4.1))
像素大小:	2.81 μm × 2.81 μm

像素格式

感測器位深:	12-Bit, 14-Bit, 16-Bit
單色像素格式:	mono12, mono14, mono16

影像性能

動態範圍: 77.8 dB

訊噪比: 44.4 dB

時序與增益

最大影格率: 12.4 fps

曝光時間: 60 μ s to 60 s

增益: 0.0 dB to 24.0 dB

I/O 與電源

非隔離線: 0 x LVDS input, 0 x LVDS output, 0 x TTL input, 0 x TTL output, 2 x 24V input, 4 x Open drain output,

特定非隔離線: 1 x RS232 input, 1 x RS232 output, 0 x RS422 input, 0 x RS422 output,

光隔離線: 1 x Optical isolated input, 0 x Optical isolated input,

電源供應: 10 to 25VDC, Power over CoaXPress

功耗: External: 17 W (typical)

操作條件

操作溫度 (機殼): -10 °C to 60 °C

機械特性

機殼尺寸 (長 x 寬 x 高 mm): 86 x 80 x 80

防護等級: IP30

鏡頭接口: M72x0.75

重量: 600 g

板載記憶體與 FPGA

非揮發性記憶體 (Flash): 160 MByte

介面

數位介面: cxp-12 with 4 connections

介面連接器: (micro-BNC)

FW 功能 – 影像控制

曝光模式: Manual, Auto

增益模式: Auto, Manual

影像控制功能: FW Features - Image Control

FW 功能 – 相機控制

觸發模式/同步:

INTERNAL, SOFTWARE, EXTERNAL

相機控制功能:

PoCxP, User Sets, PWM(4), Sequencer,

Monochrome

(not included: lens- and light source characteristics)

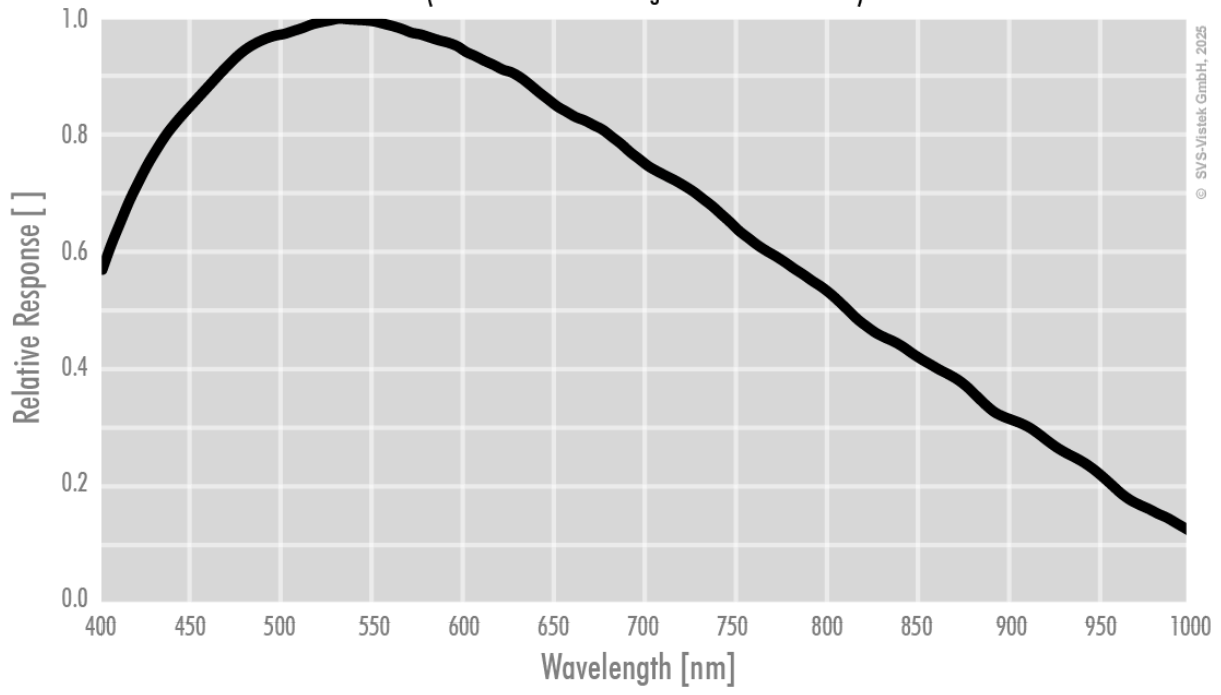

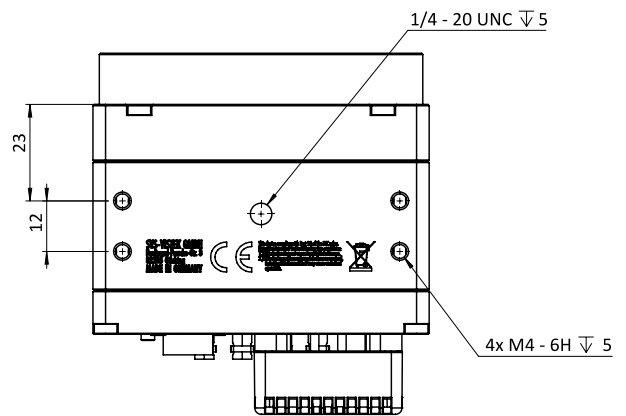
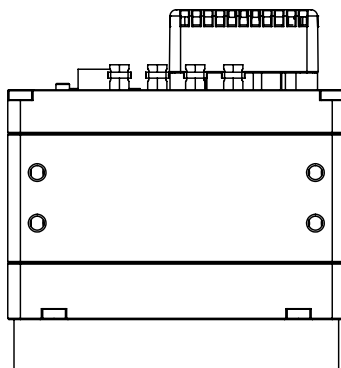
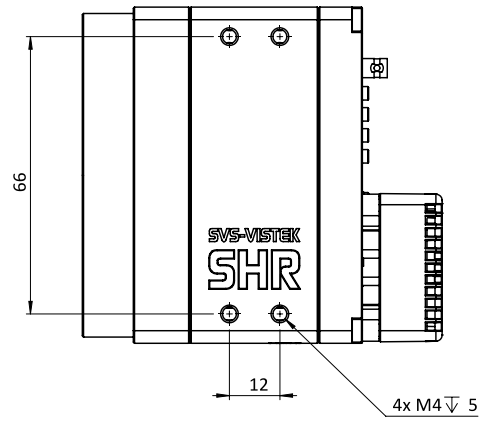
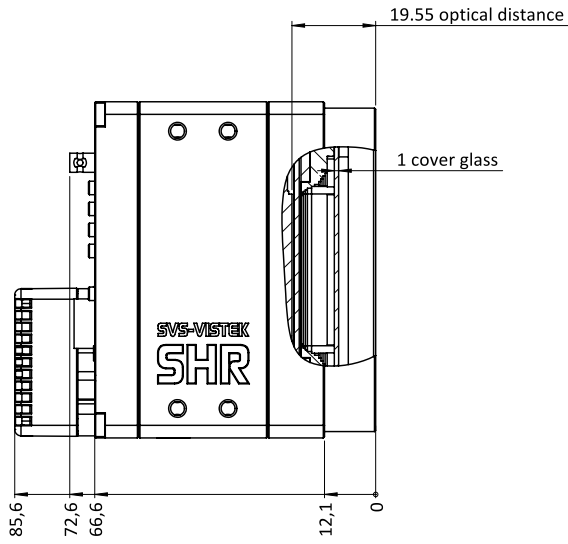
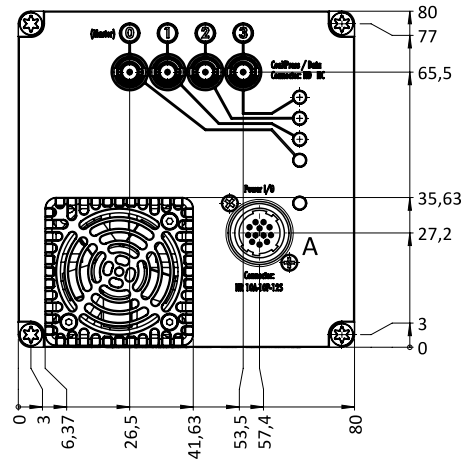
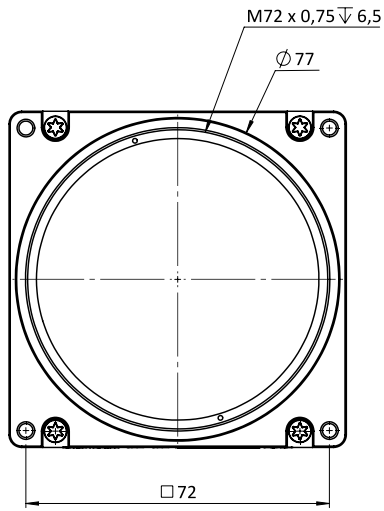

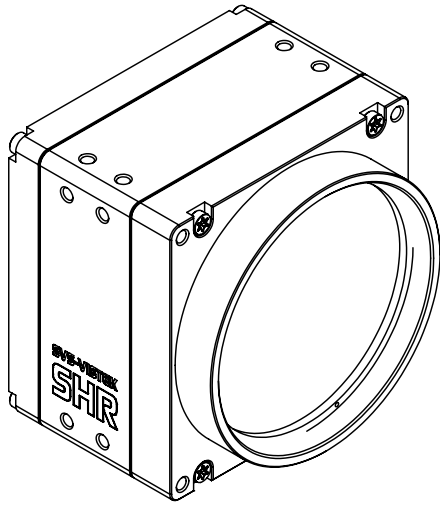

I/O 引脚分配

Hirose 12 Pin

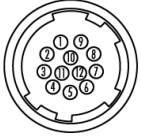

1	VIN - (GND)	7	OUT1 (open drain)
2	VIN+ (10V to 25V DC)	8	OUT2 (open drain)
3	IN4 (RXD RS232)	9	IN3+ (opto In+)
4	OUT4 (TXD RS232)	10	IN3- (opto In-)
5	IN1 (0-24V)	11	OUT3 (open drain)
6	IN2 (0-24V)	12	OUT0 (open drain)