



一般

型號:	hr51MCX
產品編號:	F004102
產品系列:	HR CoaXPress
狀態:	Available

感測器

感測器類型:	Area scan
色度:	Mono
光譜:	Visible
光譜範圍:	400 nm to 1000 nm
解析度:	8,416 × 6,032 (51.00 MP)
感測器型號:	Gpixel GMAX4651
感測器架構 (材料):	cmos
快門類型:	global-shutter
感測器尺寸:	38.71 × 27.75 mm (47.63 mm, 35mm Full Frame)
像素大小:	4.60 μm × 4.60 μm

像素格式

感測器位深:	8-Bit,12-Bit
單色像素格式:	mono8, mono12

影像性能

動態範圍:	65 dB
訊噪比:	42.6 dB

時序與增益

最大影格率:	30 fps
曝光時間:	16 μ s to 60 s
增益:	0.0 dB to 40.0 dB

I/O 與電源

非隔離線:	0 x LVDS input, 0 x LVDS output, 0 x TTL input, 0 x TTL output, 2 x 24V input, 4 x Open drain output,
特定非隔離線:	1 x RS232 input, 1 x RS232 output, 0 x RS422 input, 0 x RS422 output,
光隔離線:	1 x Optical isolated input, 0 x Optical isolated input,
電源供應:	10 to 25VDC, Power over CoaXPress
功耗:	External: 13 W (typical)

機械特性

機殼尺寸 (長 x 寬 x 高 mm):	76 x 70 x 70
濾光片/保護玻璃:	N-BK7 - AR coating 380-850nm
防護等級:	IP30
鏡頭接口:	M58x0.75
重量:	380 g

板載記憶體與 FPGA

非揮發性記憶體 (Flash):	160 MByte
------------------	-----------

介面

數位介面:	cxp-6 with 4 connections
介面連接器:	(Din1.0/2.3)

FW 功能 – 影像控制

曝光模式:	Manual, Auto
增益模式:	Auto, Manual
影像控制功能:	FW Features - Image Control

FW 功能 – 相機控制

觸發模式/同步:

INTERNAL, SOFTWARE, EXTERNAL

相機控制功能:

PoCxP, User Sets, PWM(4), Sequencer,

Monochrome

(not included: lens- and light source characteristics)

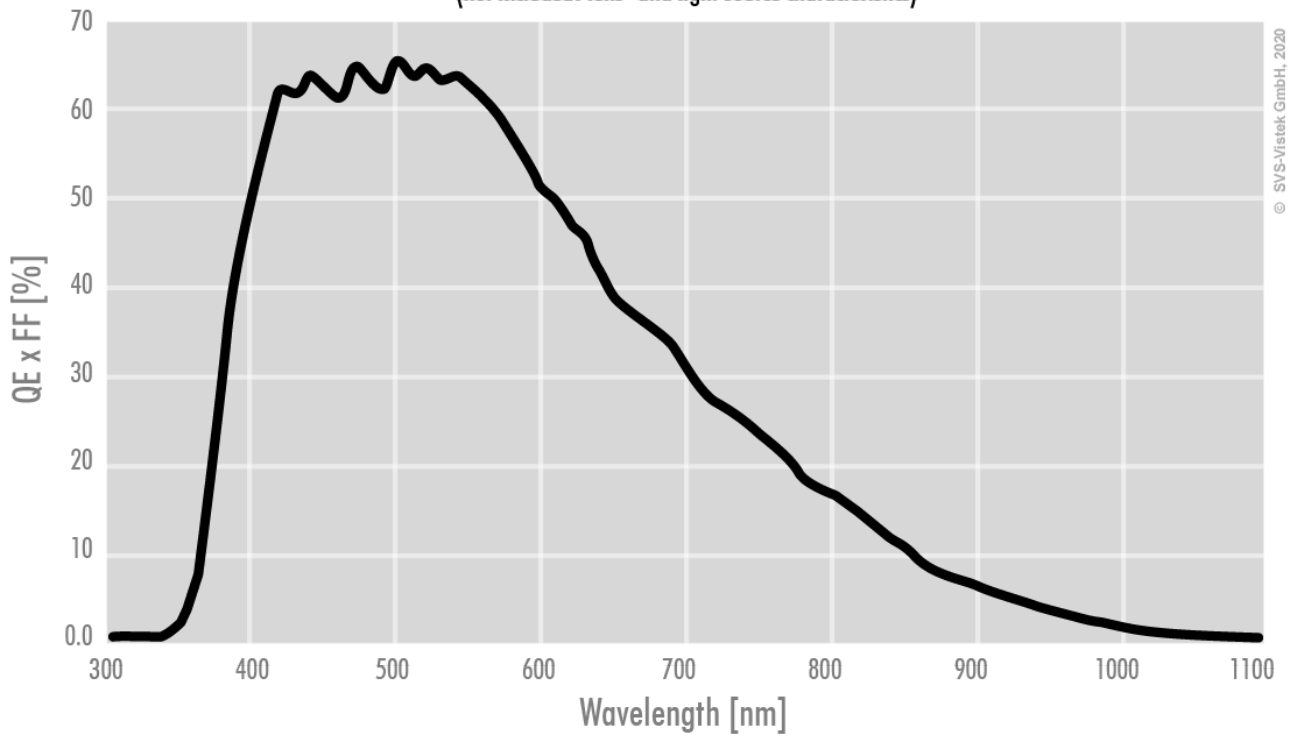

front

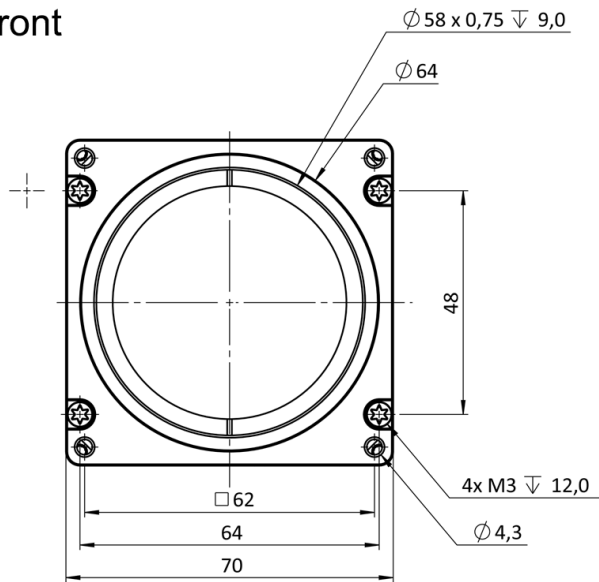

back

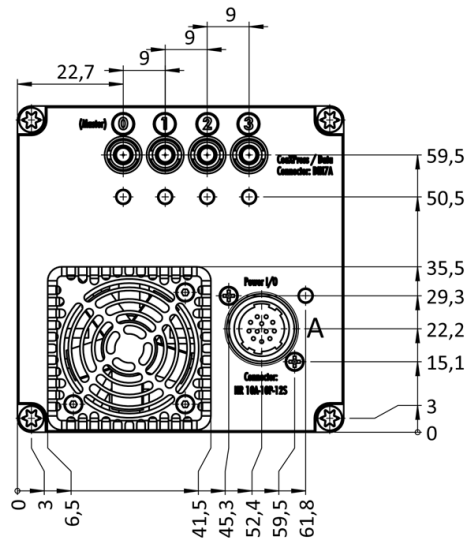

cross section

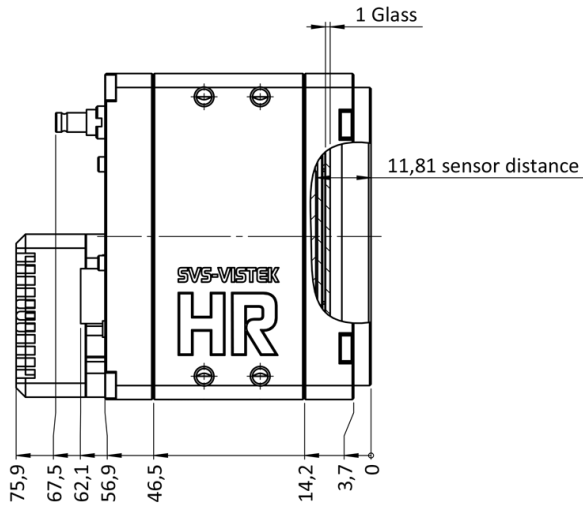

right side

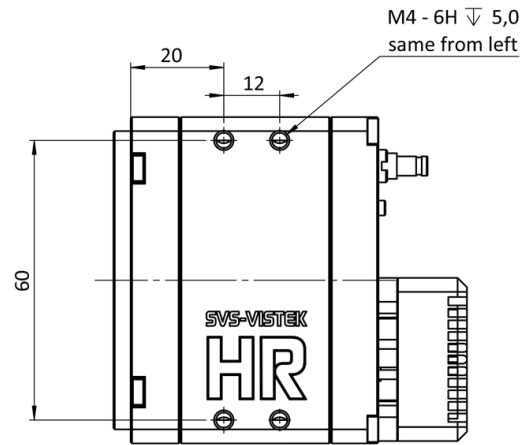

top

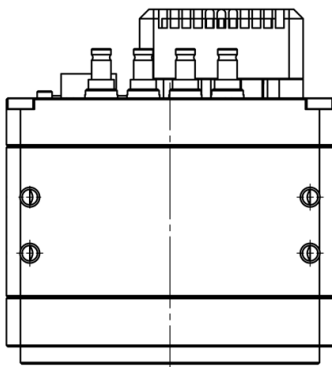

bottom

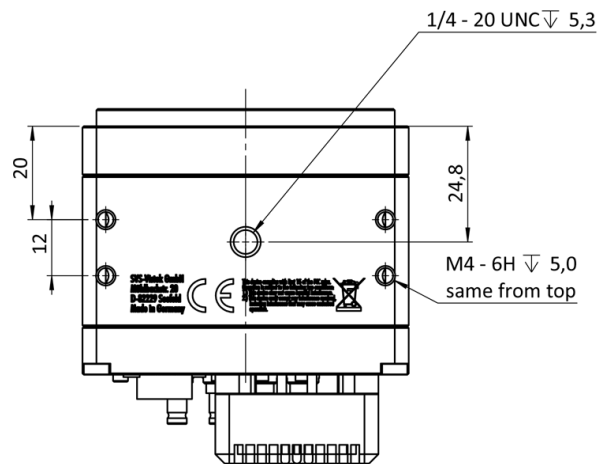

3D

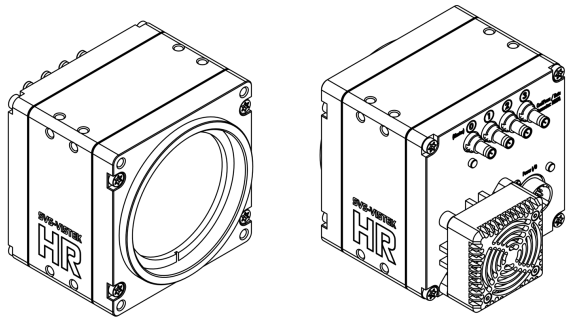

I/O 引脚分配

Hirose 12 Pin



1	VIN - (GND)	7	OUT 1 (open drain)
2	VIN + (10 V to 25 V DC)	8	OUT 2 (open drain)
3	IN 4 (RXD RS232)	9	IN 3 + (opto In +)
4	OUT 4 (TXD RS232)	10	IN 3 - (opto In -)
5	IN 1 (0-24V)	11	OUT 3 (open drain)
6	IN 2 (0-24V)	12	OUT 0 (open drain)