



### 一般

型號:	hr65MXGE
產品編號:	F004121
產品系列:	HR 10GigE
狀態:	Available

### 感測器

感測器類型:	Area scan
色度:	Mono
光譜:	Visible
光譜範圍:	400 nm to 1000 nm
解析度:	9,344 × 7,000 (65.00 MP)
感測器型號:	Gpixel GMAX3265
感測器架構 (材料):	cmos
快門類型:	global-shutter
感測器尺寸:	29.9 × 22.4 mm (37.36 mm, 37.4mm)
像素大小:	3.20 μm × 3.20 μm

### 像素格式

感測器位深:	8-Bit,12-Bit
單色像素格式:	mono8, mono12

## 影像性能

動態範圍: 65.6 dB

訊噪比: 40 dB

## 時序與增益

最大影格率: 17.4 fps

曝光時間: 62  $\mu$ s to 60 s

增益: 0.0 dB to 18.0 dB

## I/O 與電源

非隔離線: 0 x LVDS input, 0 x LVDS output, 0 x TTL input, 0 x TTL output, 2 x 24V input, 4 x Open drain output,

特定非隔離線: 1 x RS232 input, 1 x RS232 output, 0 x RS422 input, 0 x RS422 output,

光隔離線: 1 x Optical isolated input, 0 x Optical isolated input,

電源供應: 10 to 25VDC, Power over Ethernet (POE+, in option -P)

功耗: External: 14 W (typical)

## 機械特性

機殼尺寸 (長 x 寬 x 高 mm): 76 x 70 x 70

濾光片/保護玻璃: N-BK7 - AR coating

防護等級: IP30

鏡頭接口: M58x0.75

重量: 420 g

## 板載記憶體與 FPGA

影像緩衝區 (RAM): 448 MByte

非揮發性記憶體 (Flash): 32 MByte

## 介面

數位介面: 10gige

介面連接器: (RJ-45)

## FW 功能 – 影像控制

曝光模式: Manual, Auto, External

增益模式: Auto, Manual

影像控制功能: FW Features - Image Control

## FW 功能 – 相機控制

觸發模式/同步:

INTERNAL, SOFTWARE, EXTERNAL

相機控制功能:

User Sets, POE, PWM(4), Sequencer,

# Monochrome

(not included: lens- and light source characteristics)

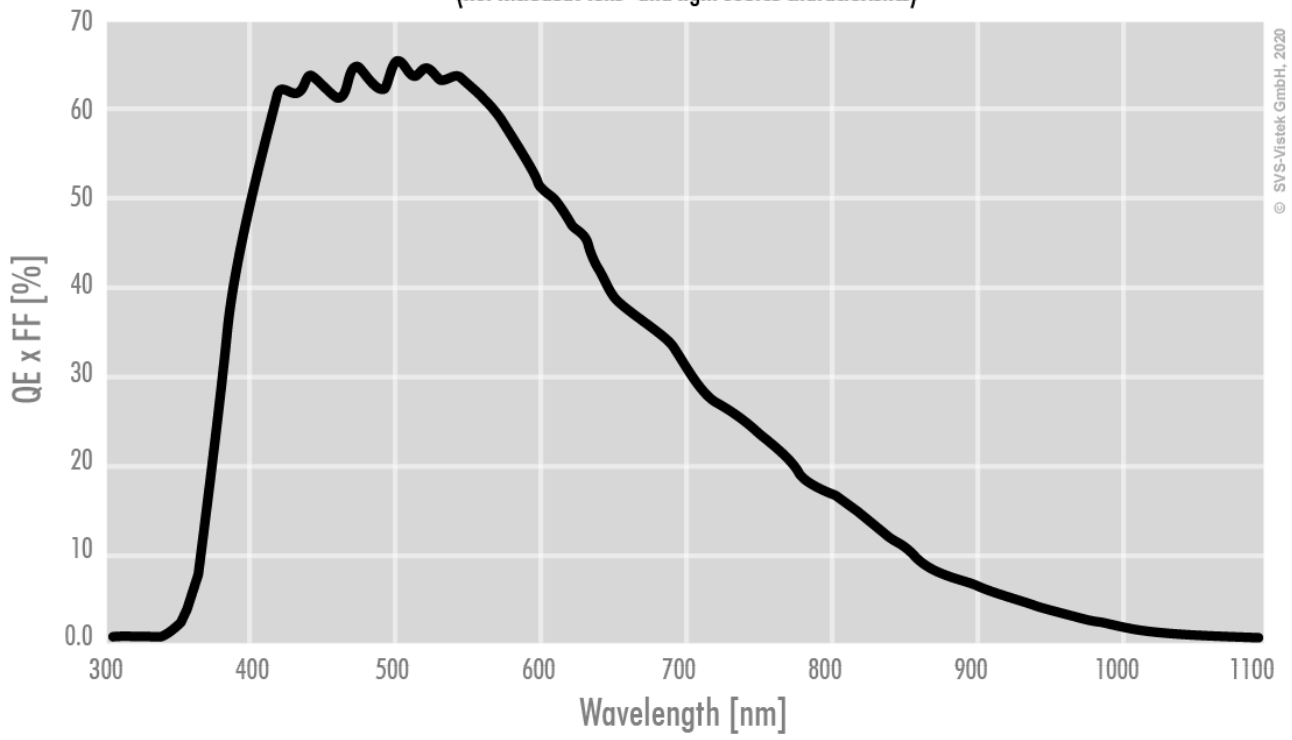



3D

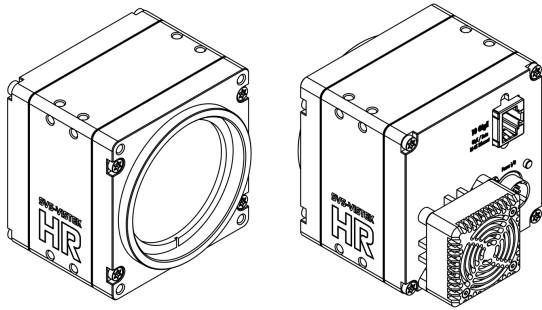

## I/O 引腳分配

Hirose 12 Pin



1	VIN - (GND)	7	OUT 1 (open drain)
2	VIN + (10 V to 25 V DC)	8	OUT 2 (open drain)
3	IN 4 (RXD RS232)	9	IN 3 + (opto In +)
4	OUT 4 (TXD RS232)	10	IN 3 - (opto In -)
5	IN 1 (0-24V)	11	OUT 3 (open drain)
6	IN 2 (0-24V)	12	OUT 0 (open drain)