

HR 10GigE

hr455MXGE



一般

型號:	hr455MXGE
產品編號:	F004098
產品系列:	HR 10GigE
狀態:	Available

感測器

感測器類型:	Area scan
色度:	Mono
光譜:	Visible
光譜範圍:	400 nm to 1000 nm
解析度:	9,568 × 6,380 (61.00 MP)
感測器型號:	Sony IMX455
感測器架構 (材料):	cmos
快門類型:	rolling-shutter
感測器尺寸:	35.98 × 23.99 mm (43.24 mm, 43.3mm (Type 2.7))
像素大小:	3.76 μm × 3.76 μm

像素格式

感測器位深:	8-Bit,12-Bit,16-Bit
單色像素格式:	mono8, mono12, mono16

影像性能

動態範圍: 81.4 dB

訊噪比: 47 dB

時序與增益

最大影格率: 18 fps

曝光時間: 34 μ s to 60 s

增益: 0.0 dB to 36.0 dB

I/O 與電源

非隔離線: 0 x LVDS input, 0 x LVDS output, 0 x TTL input, 0 x TTL output, 2 x 24V input, 4 x Open drain output,

特定非隔離線: 1 x RS232 input, 1 x RS232 output, 0 x RS422 input, 0 x RS422 output,

光隔離線: 1 x Optical isolated input, 0 x Optical isolated input,

電源供應: 10 to 25VDC, Power over Ethernet (POE+, in option -P)

功耗: External: 18 W (typical)

操作條件

操作溫度 (機殼): -10 °C to 60 °C

機械特性

機殼尺寸 (長 x 寬 x 高 mm): 78 x 70 x 70

濾光片/保護玻璃: N-BK7 - AR coating

防護等級: IP30

鏡頭接口: M58x0.75

重量: 420 g

板載記憶體與 FPGA

影像緩衝區 (RAM): 448 MByte

介面

數位介面: 10gige

介面連接器: (RJ-45)

FW 功能 – 影像控制

曝光模式: Manual, Auto, External

增益模式: Auto, Manual

FW 功能 – 影像控制

影像控制功能:

FW Features - Image Control

FW 功能 – 相機控制

觸發模式/同步:

INTERNAL, SOFTWARE, EXTERNAL

相機控制功能:

User Sets, POE, PWM(4), Sequencer,

Monochrome

(not included: lens- and light source characteristics)

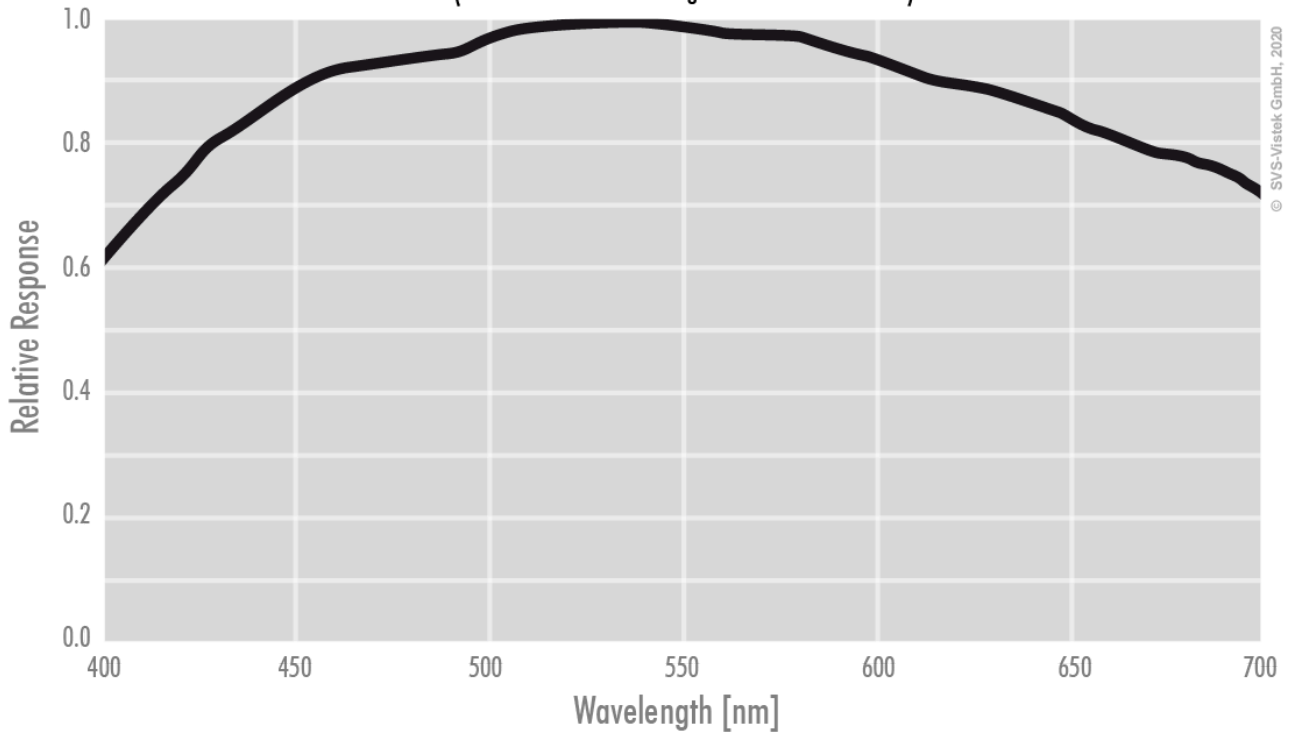

front

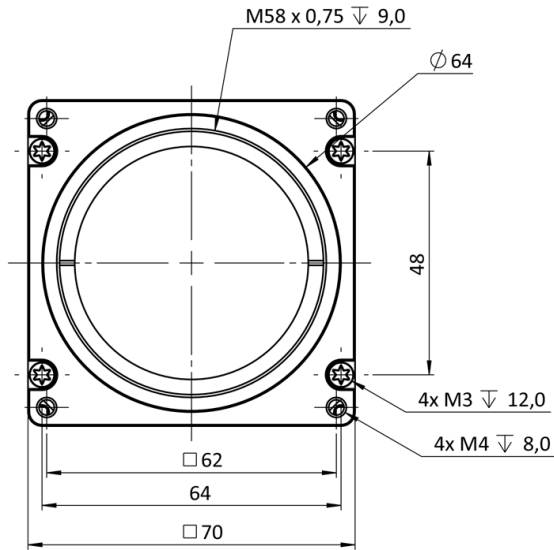

back

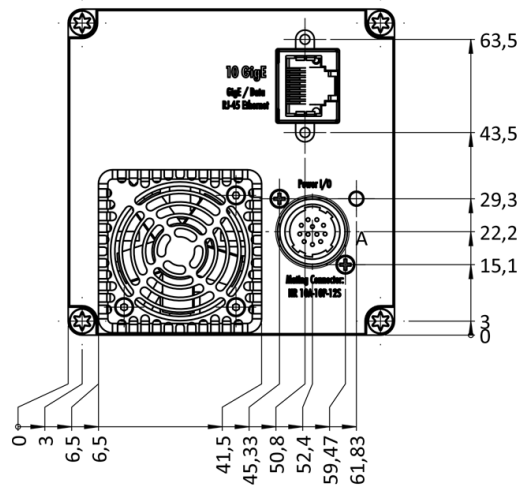

cross section

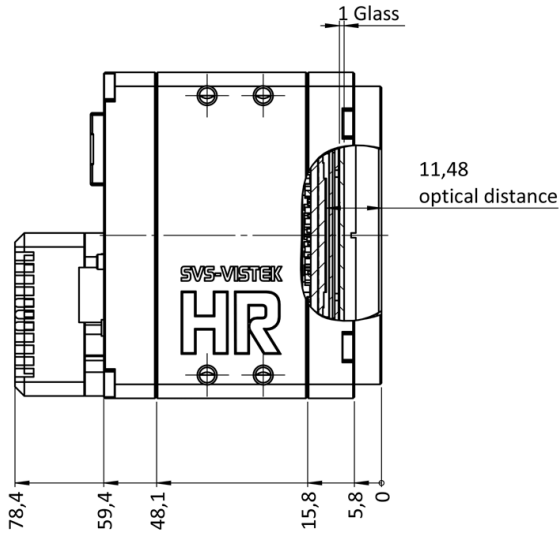

right side

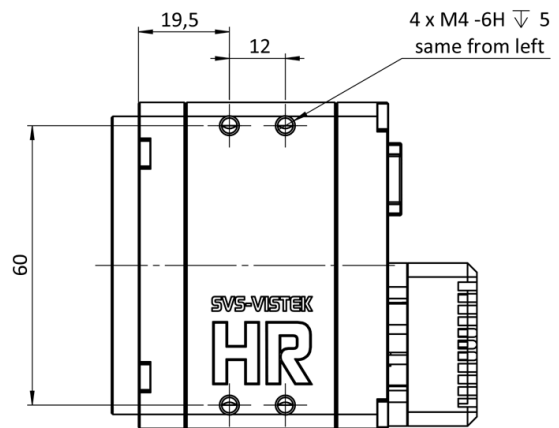

top

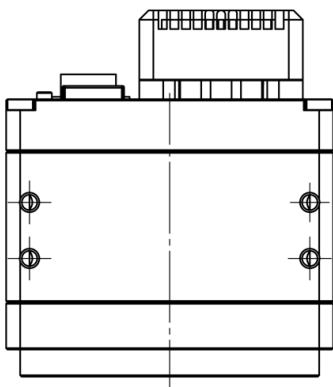

bottom

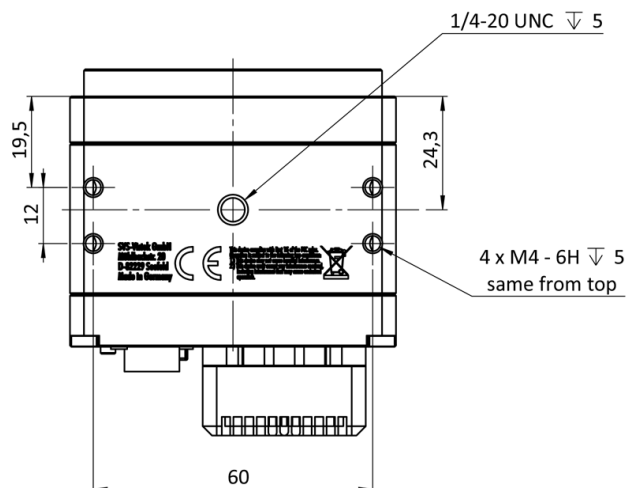

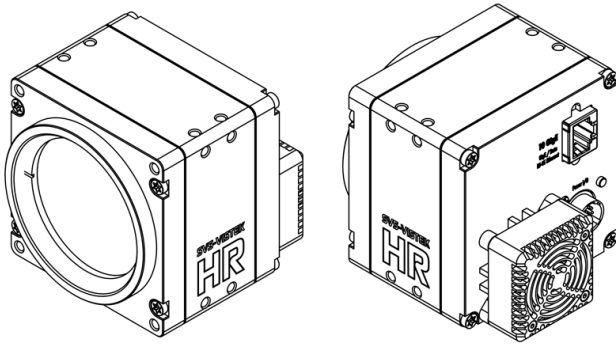

I/O 引腳分配

Hirose 12 Pin

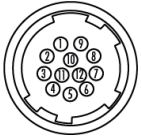

1	VIN - (GND)	7	OUT 1 (open drain)
2	VIN + (10 V to 25 V DC)	8	OUT 2 (open drain)
3	IN 4 (RXD RS232)	9	IN 3 + (opto In +)
4	OUT 4 (TXD RS232)	10	IN 3 - (opto In -)
5	IN 1 (0-24V)	11	OUT 3 (open drain)
6	IN 2 (0-24V)	12	OUT 0 (open drain)