

HR 10GigE

hr387CXGE



一般

型號:	hr387CXGE
產品編號:	F004076
產品系列:	HR 10GigE
狀態:	Available

感測器

感測器類型:	Area scan
色度:	Color
光譜:	Visible
光譜範圍:	400 nm to 1000 nm
解析度:	5,440 × 3,076 (16.70 MP)
感測器型號:	Sony IMX387
感測器架構 (材料):	cmos
快門類型:	global-shutter
感測器尺寸:	18.77 × 10.61 mm (21.56 mm, 21.7mm (Type 4/3))
像素大小:	3.45 μm × 3.45 μm

像素格式

感測器位深:	8-Bit,12-Bit
RGB 像素格式:	bayer8, bayer12

時序與增益

最大影格率:	56.4 fps
曝光時間:	21 μ s to 60 s
增益:	0.0 dB to 48.0 dB

I/O 與電源

非隔離線:	0 x LVDS input, 0 x LVDS output, 0 x TTL input, 0 x TTL output, 2 x 24V input, 4 x Open drain output,
特定非隔離線:	1 x RS232 input, 1 x RS232 output, 0 x RS422 input, 0 x RS422 output,
光隔離線:	1 x Optical isolated input, 0 x Optical isolated input,
電源供應:	10 to 25VDC, Power over Ethernet (POE+, in option -P)
功耗:	External: 15.5 W (typical)

機械特性

機殼尺寸 (長 x 寬 x 高 mm):	80 x 70 x 70
濾光片/保護玻璃:	N-BK7 - AR coating
防護等級:	IP30
鏡頭接口:	M58x0.75
重量:	400 g

板載記憶體與 FPGA

影像緩衝區 (RAM):	448 MByte
非揮發性記憶體 (Flash):	32 MByte

介面

數位介面:	10gige
介面連接器:	(RJ-45)

FW 功能 – 影像控制

曝光模式:	Manual, Auto, External
增益模式:	Auto, Manual
白平衡模式:	auto, manual
影像控制功能:	FW Features - Image Control

FW 功能 – 相機控制

觸發模式/同步:	INTERNAL, SOFTWARE, EXTERNAL
相機控制功能:	User Sets, POE, PWM(4), Sequencer,

Sensor data – excludes camera cover- or IR-cut filter characteristics

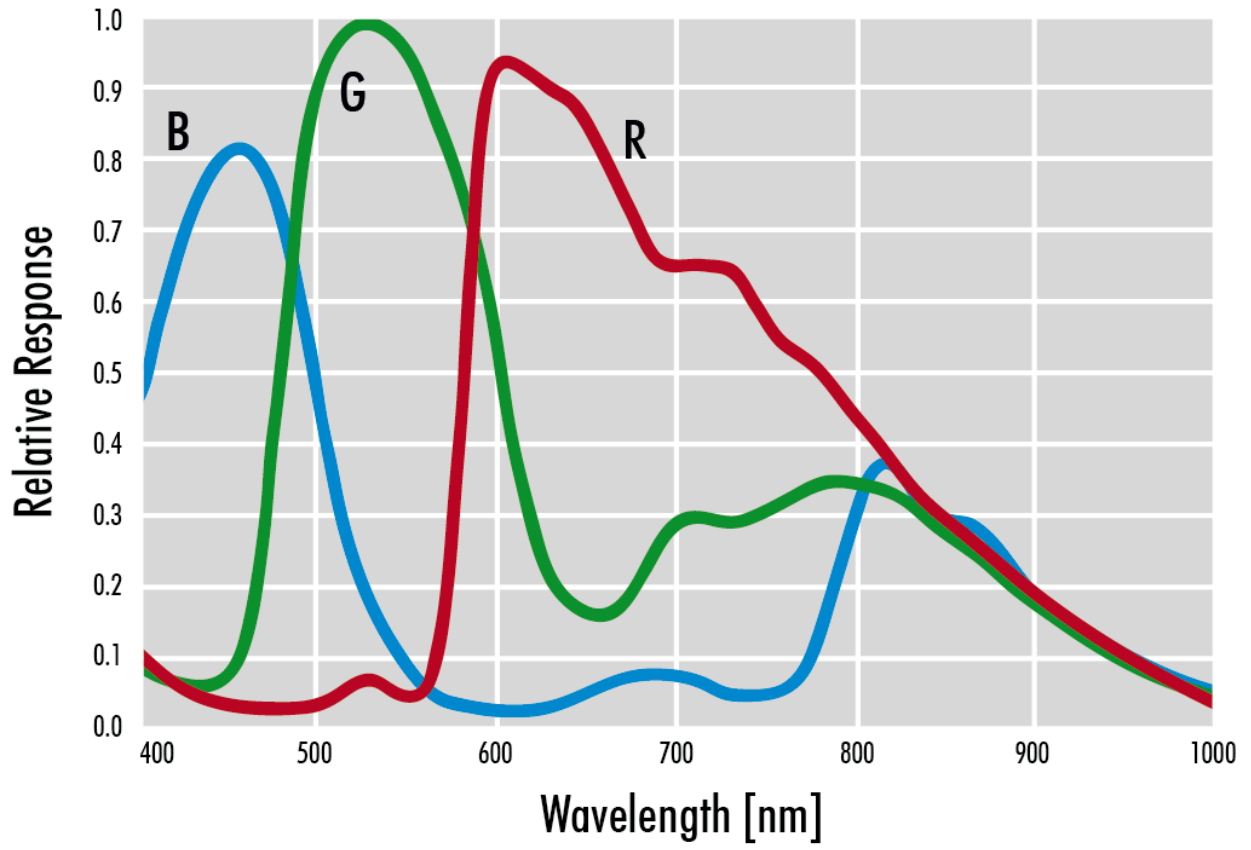

front view

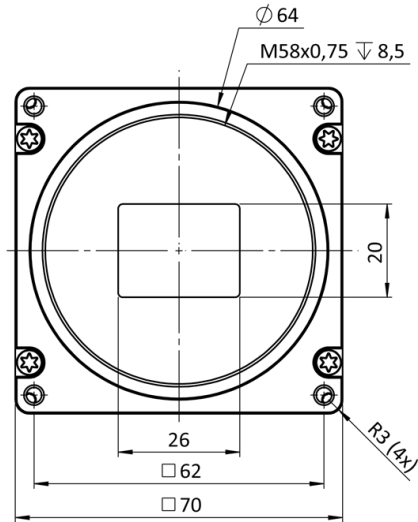

back view

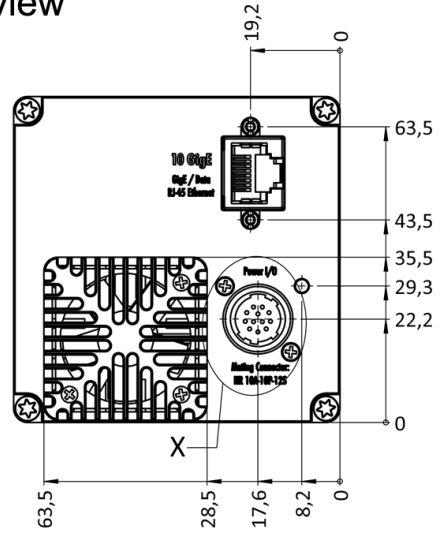

cross section

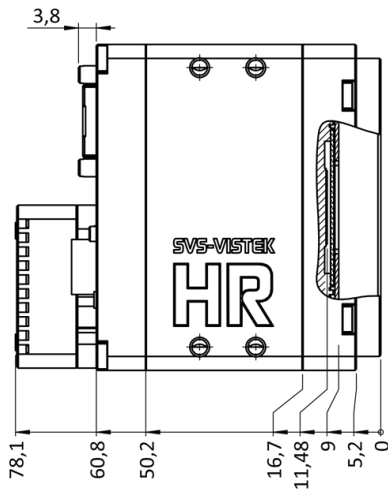

right view

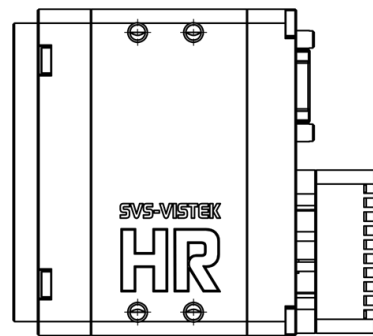

top view

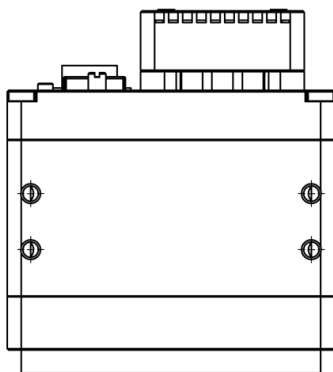

bottom view

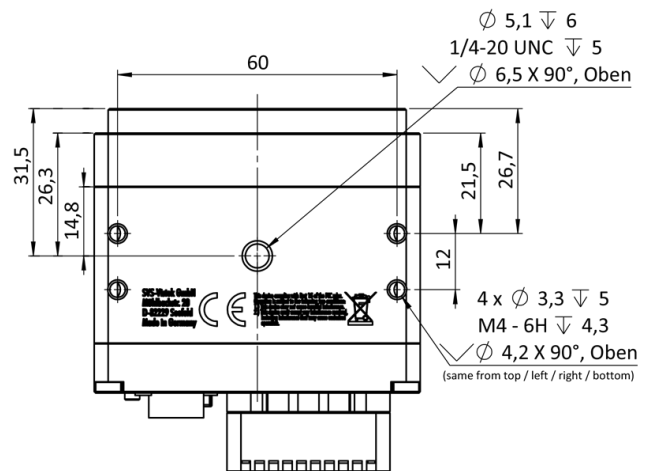

3D view

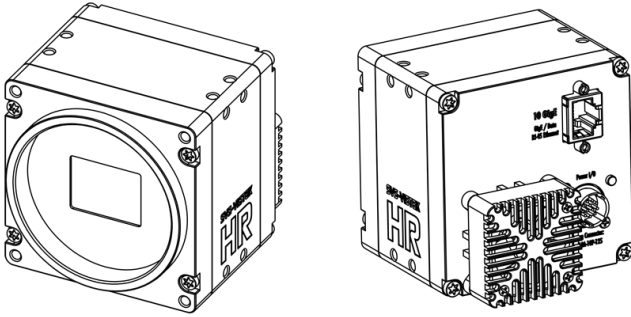

I/O 引腳分配

Hirose 12 Pin

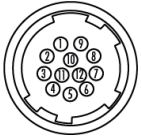

1	VIN - (GND)	7	OUT 1 (open drain)
2	VIN + (10 V to 25 V DC)	8	OUT 2 (open drain)
3	IN 4 (RXD RS232)	9	IN 3 + (opto In +)
4	OUT 4 (TXD RS232)	10	IN 3 - (opto In -)
5	IN 1 (0-24V)	11	OUT 3 (open drain)
6	IN 2 (0-24V)	12	OUT 0 (open drain)