

# FXO 10GigE

fxo546MXGE



## 一般

型號:	fxo546MXGE
產品編號:	F002152
產品系列:	FXO 10GigE
狀態:	Available

## 感測器

感測器類型:	Area scan
色度:	Mono
光譜:	Visible
光譜範圍:	400 nm to 1000 nm
解析度:	2,840 × 2,840 (8.10 MP)
感測器型號:	Sony IMX546
感測器架構 (材料):	cmos
快門類型:	global-shutter
感測器尺寸:	7.78 × 7.78 mm (11 mm, 11.1mm (Type 2/3))
像素大小:	2.74 μm × 2.74 μm

## 像素格式

感測器位深:	8-Bit,12-Bit
單色像素格式:	mono8, mono12

## 時序與增益

最大影格率:	88 fps
曝光時間:	6 $\mu$ s to 60 s
增益:	0.0 dB to 48.0 dB

## I/O 與電源

非隔離線:	0 x LVDS input, 0 x LVDS output, 0 x TTL input, 0 x TTL output, 2 x 24V input, 4 x Open drain output,
特定非隔離線:	1 x RS232 input, 1 x RS232 output, 0 x RS422 input, 0 x RS422 output,
光隔離線:	1 x Optical isolated input, 0 x Optical isolated input,
電源供應:	10 to 25VDC, Power over Ethernet
功耗:	External: 9 W (typical)

## 操作條件

操作溫度 (機殼):	-10 °C to 60 °C
------------	-----------------

## 機械特性

機殼尺寸 (長 x 寬 x 高 mm):	76 x 50 x 50
濾光片/保護玻璃:	K9 - AR coating - 400-850nm
防護等級:	IP30
鏡頭接口:	C-Mount
重量:	240 g

## 板載記憶體與 FPGA

影像緩衝區 (RAM):	896 MByte
非揮發性記憶體 (Flash):	32 MByte

## 介面

數位介面:	10gige
介面連接器:	(RJ-45)

## FW 功能 – 影像控制

曝光模式:	Manual, Auto, External
增益模式:	Auto, Manual
影像控制功能:	FW Features - Image Control

## FW 功能 – 相機控制

觸發模式/同步:

INTERNAL, SOFTWARE, EXTERNAL

相機控制功能:

PTP, User Sets, POE, PWM(4), Sequencer,

# Monochrome

(not included: lens- and light source characteristics)

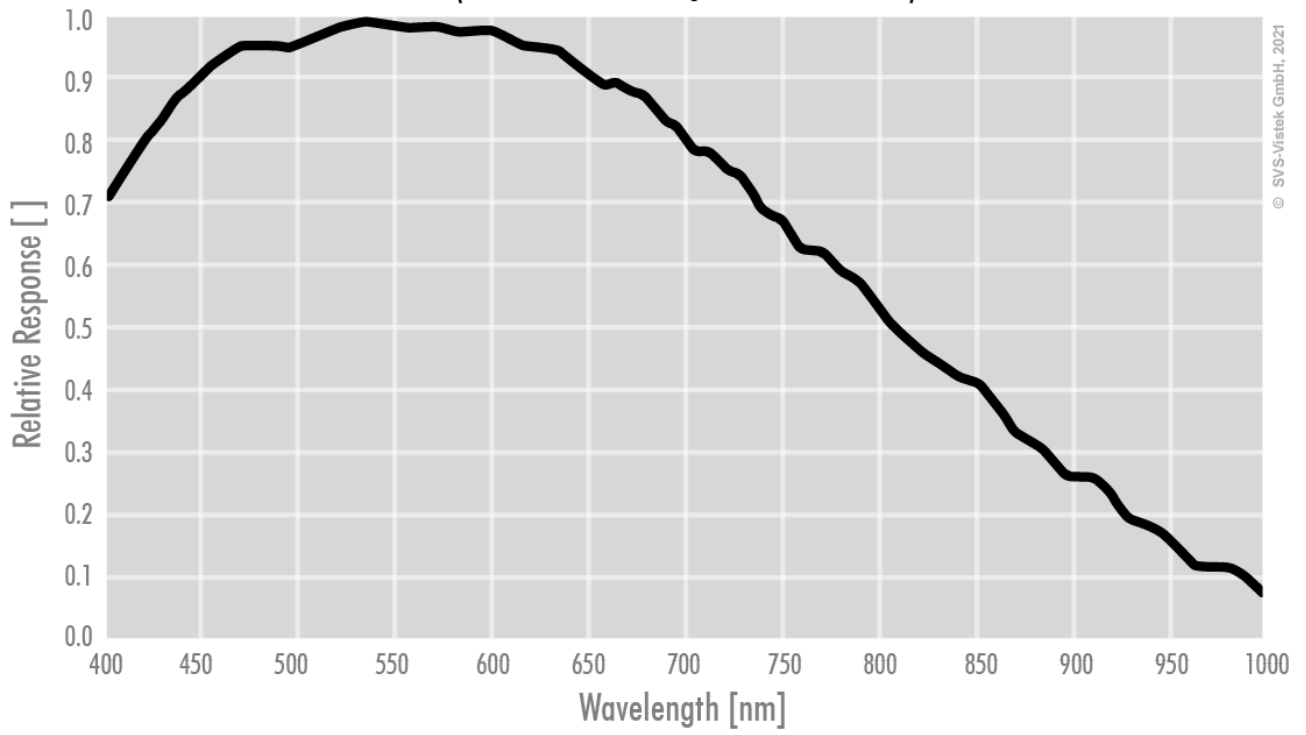

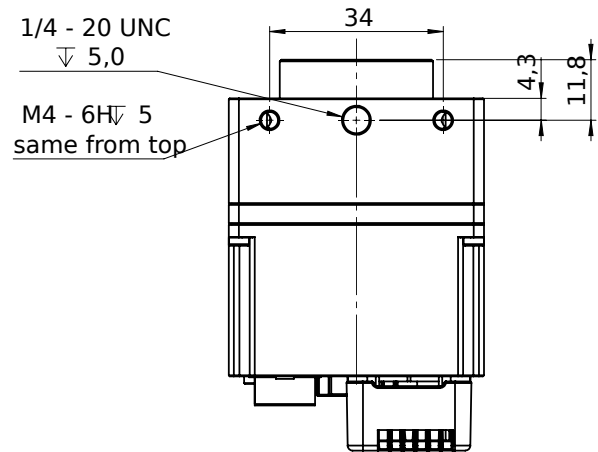
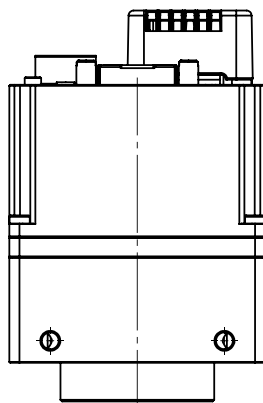
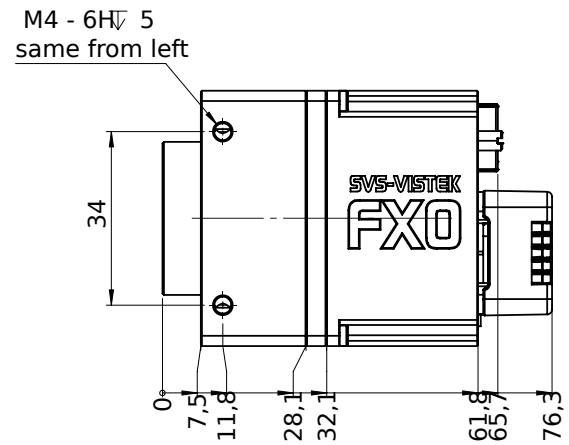
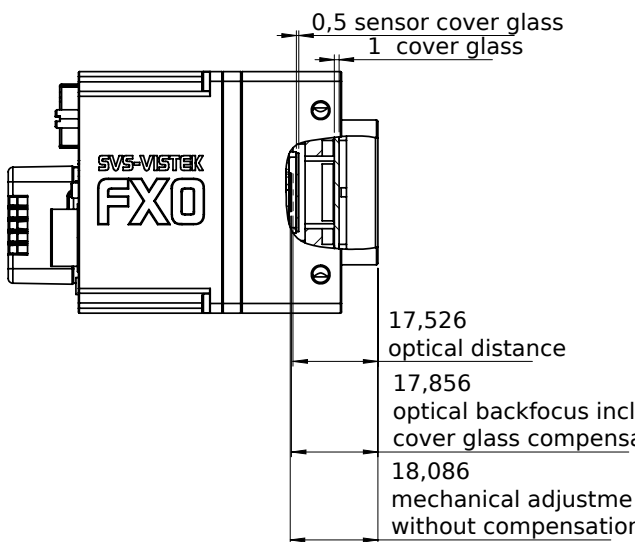
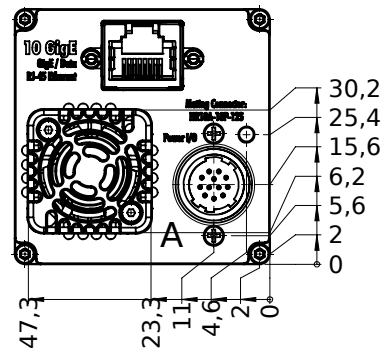
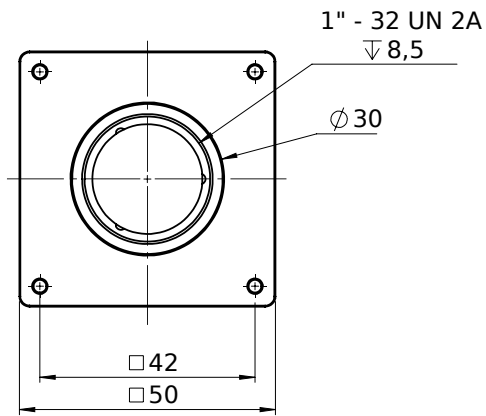

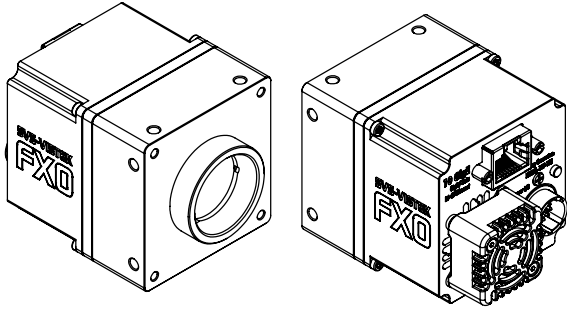

## I/O 引腳分配

Hirose 12 Pin



1	VIN - (GND)	7	OUT 1 (open drain)
2	VIN + (10 V to 25 V DC)	8	OUT 2 (open drain)
3	IN 4 (RXD RS232)	9	IN 3 + (opto In +)
4	OUT 4 (TXD RS232)	10	IN 3 - (opto In -)
5	IN 1 (0-24V)	11	OUT 3 (open drain)
6	IN 2 (0-24V)	12	OUT 0 (open drain)