

EXO Camera Link

exo304MCL



一般

型號:	exo304MCL
產品編號:	F001765
產品系列:	EXO Camera Link
狀態:	Available

感測器

感測器類型:	Area scan
色度:	Mono
光譜:	Visible
光譜範圍:	400 nm to 1000 nm
解析度:	4,096 × 3,000 (12.30 MP)
感測器型號:	Sony IMX304
感測器架構 (材料):	cmos
快門類型:	global-shutter
感測器尺寸:	14.13 × 10.35 mm (17.52 mm, 17.6mm (Type 1.1))
像素大小:	3.45 μm × 3.45 μm

像素格式

感測器位深:	8-Bit,12-Bit
單色像素格式:	mono8, mono12

影像性能

動態範圍:	72 dB
訊噪比:	39.5 dB

時序與增益

最大影格率:	20 fps
曝光時間:	29 μ s to 60 s
增益:	0.0 dB to 48.0 dB

I/O 與電源

非隔離線:	0 x LVDS input, 0 x LVDS output, 0 x TTL input, 0 x TTL output, 2 x 24V input, 4 x Open drain output,
特定非隔離線:	1 x RS232 input, 1 x RS232 output, 0 x RS422 input, 0 x RS422 output,
光隔離線:	1 x Optical isolated input, 0 x Optical isolated input,
電源供應:	10 to 25VDC
功耗:	External: 4 W (typical)

操作條件

操作溫度 (機殼):	-10 °C to 60 °C
------------	-----------------

機械特性

機殼尺寸 (長 x 寬 x 高 mm):	43 x 50 x 50
濾光片/保護玻璃:	K9 - AR coating - 400-850nm
防護等級:	IP40
鏡頭接口:	C-Mount
重量:	140 g

板載記憶體與 FPGA

影像緩衝區 (RAM):	192 MByte
非揮發性記憶體 (Flash):	32 MByte

介面

數位介面:	Camera Link Base
介面連接器:	(MDR)

FW 功能 – 影像控制

曝光模式:	Manual, Auto, External
-------	------------------------

FW 功能 – 影像控制

增益模式: Auto, Manual

影像控制功能: FW Features - Image Control

FW 功能 – 相機控制

觸發模式/同步: INTERNAL, SOFTWARE, EXTERNAL

相機控制功能: User Sets, PWM(4), Sequencer,

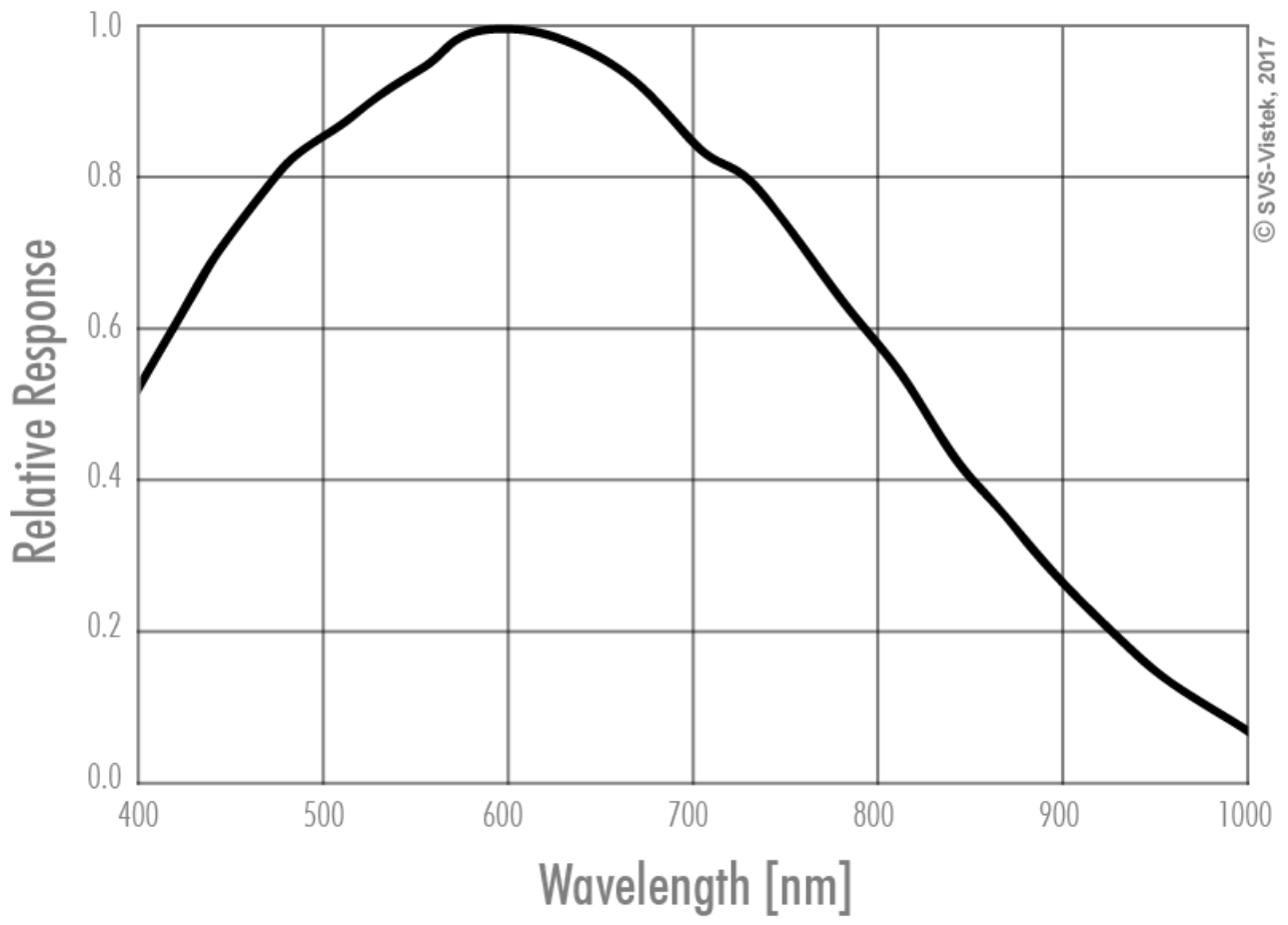

front

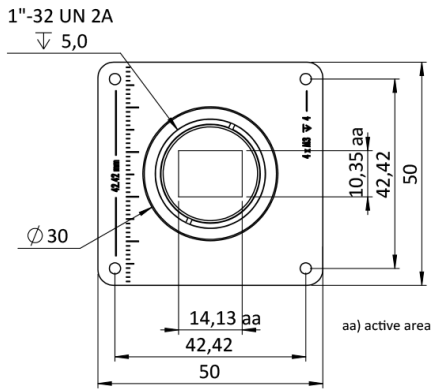

back

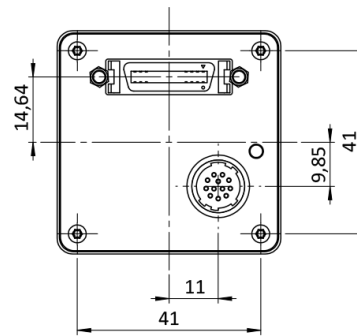

right side

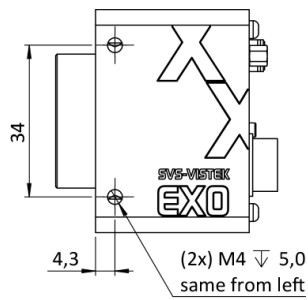

bottom

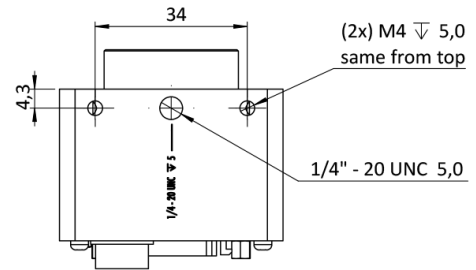

left side

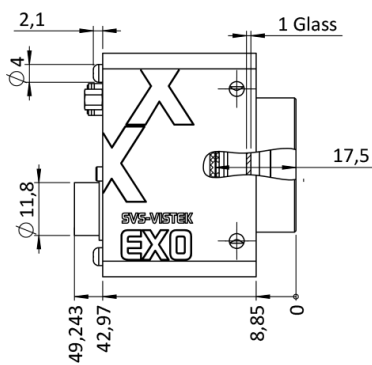

Hirose 12 Pin



1	VIN -	(GND)	7	OUT1	(open drain)
2	VIN +	(10 V to 25 V DC)	8	OUT2	(open drain)
3	IN 4	(RXD RS232)	9	IN 3 +	(opto In +)
4	OUT 4	(TXD RS232)	10	IN 3 -	(opto In -)
5	IN 1	(0-24V)	11	OUT 3	(open drain)
6	IN 2	(0-24V)	12	OUT 0	(open drain)