



Stingray F-145



- Versatile camera with Sony ICX285
- Advanced feature set
- Many variants
- Excellent image quality

Description

Sony ICX285 EXview HAD sensor, IEEE 1394b

The Stingray F-145B/F-145C incorporates the popular Sony ICX285 EXview HAD CCD sensor. In combination with the Stingray's image pre-processing functions like low-noise binning mode and High SNR mode, this camera produces clear and brilliant images even with very low light. At full resolution, it runs at 16 frames per second.

Options:

- IEEE 1394b connectors: 2 x copper (daisy chain), Hirose power: out
- Various IR cut/pass filters, various lens mounts
- Angled head, board level version, white medical housing

Specifications

Stingray	F-145
インターフェイス	IEEE 1394b - 800 Mb/s, 2 ports, daisy chain
解像度	1388 (H) × 1038 (V)
センサー	Sony ICX285
Sensor type	CCD Progressive
センサーサイズ	Type 2/3
ピクセルサイズ	6.45 μm × 6.45 μm
レンズマウント (標準搭載)	C-Mount
フレームレート (フル解像度)	16 fps
ADC	14 bit
Image buffer (RAM)	Up to 128 MByte
	Output

Stingray	F-145
Bit depth	8-14 bit
ビデオフォーマット(Mono)	Mono8, Mono12, Mono16
ビデオフォーマット(RGB)	RGB8
ビデオフォーマット(Raw)	Raw8, Raw12, Raw16
General purpose inputs/outputs (GPIOs)	
Opto-isolated I/Os	2 inputs, 4 outputs
RS232	1
Operating conditions/dimensions	
Operating temperature	+5 °C to +45 °C
Power requirements (DC)	8 V to 36 V
消費電力	<4 W (@ 12 VDC)
Mass	92 g
Body dimensions (L × W × H in mm)	72.9 × 44 × 29 (including connectors)
Regulations	CE: 2014/30/EU (EMC), 2011/65/EU (RoHS); FCC Class B

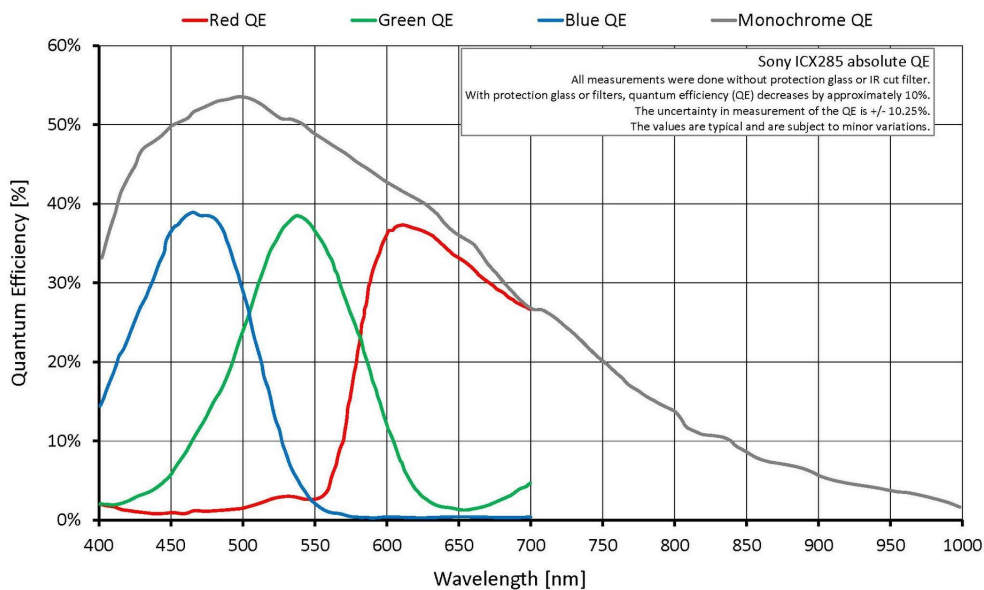

Features

- High SNR mode (up to 24 dB better signal-to-noise ratio)
- Low-noise binning mode
- Shading correction
- Defect pixel correction
- Area of interest (AOI), separate AOI for auto features



- Binning
- Decimation
- Auto gain (manual gain control: 0 to 24.4 dB)
- Auto exposure (74 μ s to 67 s)
- Auto white balance
- Look-up table (LUT)
- Hue, saturation
- Color correction
- Local color anti-aliasing
- Reverse X/Y
- Deferred image transport
- Trigger programmable, level, single, bulk, programmable delay
- Sequence mode (changes the camera settings on the fly)
- SIS (secure image signature, time stamp for trigger, frame count etc.)
- Storable user sets

Scope of delivery

- Camera and IEEE 1394b cable (other configurations on request)

Technical drawing

2 x 1394b copper

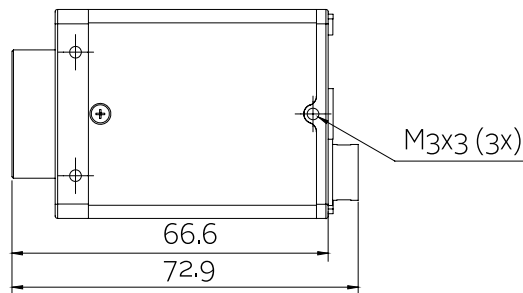
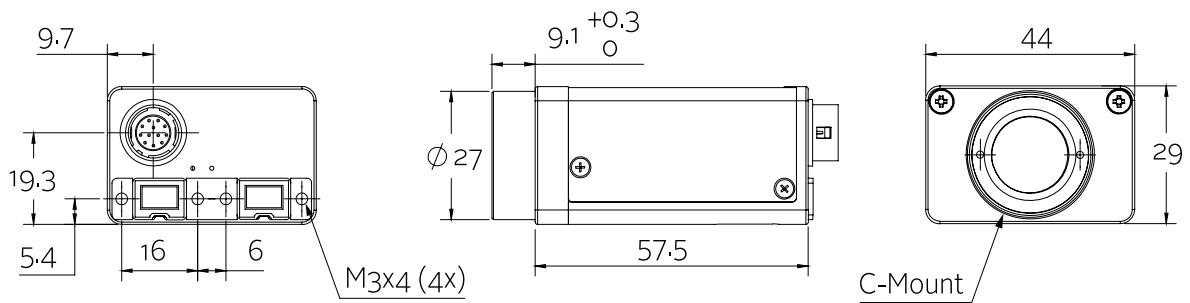
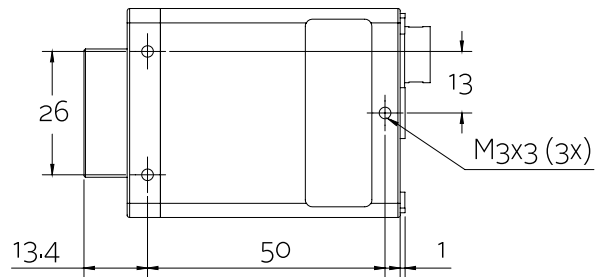



Applications

Thanks to the Sony EXview HAD ICX285 sensor and especially the High SNR mode, defect pixel correction and low-noise binning mode, Stingray F-145B/F-145C cameras are the perfect choice for low-light applications in:

- Industrial inspection and automation
- Logistics
- Science and research
- Healthcare and medical (white housing available)
- Solar cell inspection
- LCD panel inspection
- Multimedia and entertainment
- Intelligent traffic solutions (ITS)

Additionally, it is ideally suited for:

- Demanding OEM camera applications (board level versions with separate sensor board available on request)
- Daisy chaining (two copper connectors)