



Stingray F-033



- Versatile VGA camera
- Advanced feature set
- Many variants
- Excellent image quality

Description

High-quality (mid-priced) industrial VGA camera with image pre-processing

The Stingray F-033B/F-033C is a high-quality VGA camera. It is equipped with a sensitive Sony ICX414 CCD sensor and includes many image pre-processing functions. At full resolution, it runs at 84 frames per second. Higher frame rates can be reached by using a smaller area of interest (AOI), binning (b/w) or sub-sampling.

Options:

- IEEE 1394b connectors: 2 x copper (daisy chain), Hirose power: out
- Various IR cut/pass filters, various lens mounts
- Angled head, board level version, white medical housing

Specifications

Stingray	F-033
インターフェイス	IEEE 1394b - 800 Mb/s, 2 ports, daisy chain
解像度	656 (H) × 492 (V)
センサー	Sony ICX414
Sensor type	CCD Progressive
センサーサイズ	Type 1/2
ピクセルサイズ	9.9 μm × 9.9 μm
レンズマウント (標準搭載)	C-Mount
フレームレート (フル解像度)	84 fps
ADC	14 bit
Image buffer (RAM)	Up to 128 MByte
	Output

Stingray	F-033
Bit depth	8-14 bit
ビデオフォーマット(Mono)	Mono8, Mono12, Mono16
ビデオフォーマット(RGB)	RGB8
ビデオフォーマット(Raw)	Raw8, Raw12, Raw16
General purpose inputs/outputs (GPIOs)	
Opto-isolated I/Os	2 inputs, 4 outputs
RS232	1
Operating conditions/dimensions	
Operating temperature	+5 °C to +45 °C
Power requirements (DC)	8 V to 36 V
消費電力	<4 W (@ 12 VDC)
Mass	92 g
Body dimensions (L × W × H in mm)	72.9 × 44 × 29 (including connectors)
Regulations	CE: 2014/30/EU (EMC), 2011/65/EU (RoHS); FCC Class B

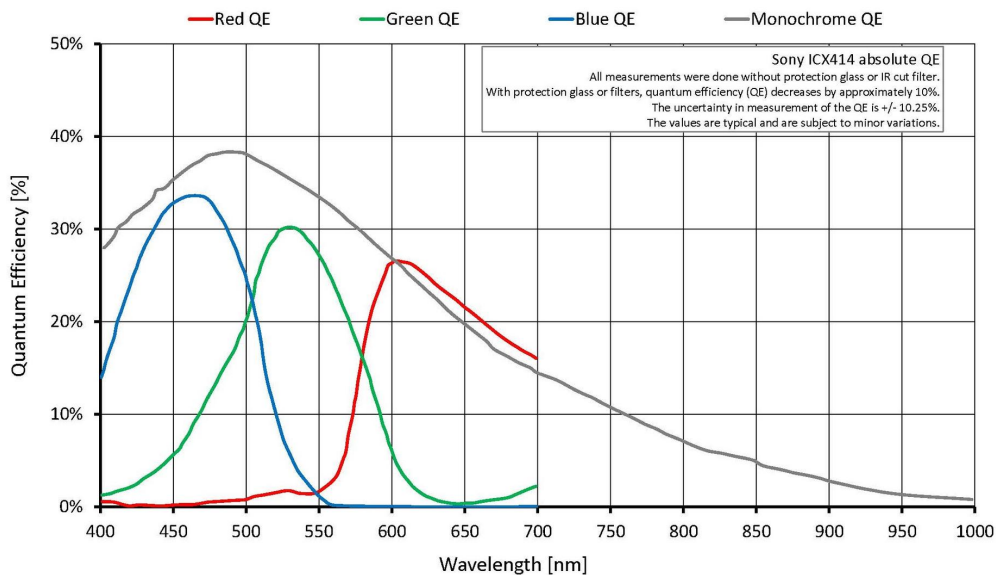

Features

- High SNR mode (up to 24 dB better signal-to-noise ratio)
- Low-noise binning mode
- Shading correction
- Defect pixel correction
- Area of interest (AOI), separate AOI for auto features



- Binning
- Decimation
- Auto gain (manual gain control: 0 to 24.4 dB)
- Auto exposure (31 μ s to 67 s)
- Auto white balance
- Look-up table (LUT)
- Hue, saturation
- Color correction
- Local color anti-aliasing
- Reverse X/Y
- Deferred image transport
- Trigger programmable, level, single, bulk, programmable delay
- Sequence mode (changes the camera settings on the fly)
- SIS (secure image signature, time stamp for trigger, frame count etc.)
- Storable user sets

Scope of delivery

- Camera and IEEE 1394b cable (other configurations on request)

Technical drawing

2 x 1394b copper

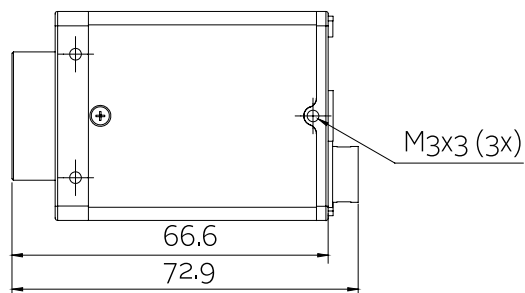
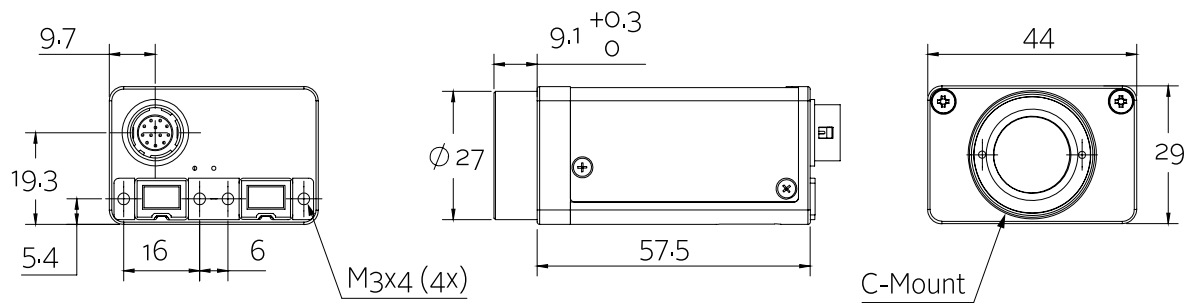
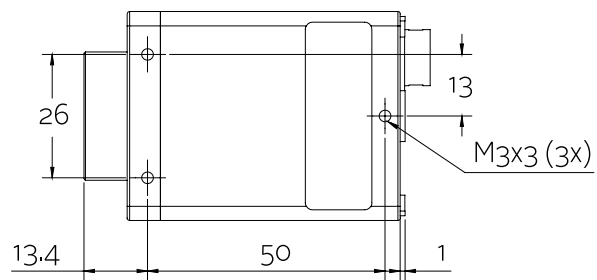



Applications

The Stingray F-033B/F-033C is a high-quality industrial VGA camera with many image pre-processing functions. It offers several opportunities for customization. This mid-priced camera fits for all sorts of applications with high demands, for example:

- Industrial inspection and automation
- Semiconductor inspection
- Logistics
- Science and research
- Healthcare and medical (white housing available)
- Ophthalmology
- Multimedia, entertainment and sports
- Intelligent traffic solutions (ITS)

Additionally, it is ideally suited for:

- Demanding OEM camera applications (board level versions with separate sensor board available on request)
- Daisy chaining (two copper connectors)