

Prosilica GX 1660



- 240 MBps with dual port LAG technology
- 3-axis motorized lens control
- High frame rate at full bit depth
- ON Semi KAI-02050 sensor

Description

GigE Vision camera, ON Semi KAI-02050 CCD sensor, 66 fps

Prosilica GX1660 is a high resolution CCD camera with dual Gigabit Ethernet ports (GigE Vision®). This camera incorporates a high-quality 2/3" ON Semiconductor KAI-02050 CCD sensor providing excellent monochrome and color image quality in 4:3 format. At full resolution, this camera has a frame rate of 66 frames per second. With a smaller region of interest higher frame rates are possible. This camera has two screw-captivated Gigabit Ethernet ports configured as a Link Aggregation Group (LAG) to provide a sustained maximum data rate of 240 MBps. It can also work at half the bandwidth (120 MBps) using a single cable. By default monochrome models ship with no optical filter and color models ship with an IRC30 IR cut filter.

Specifications

Prosilica GX	1660
インターフェイス	IEEE 802.3 1000baseT
解像度	1600 (H) × 1200 (V)
センサー	ON Semi KAI-02050
Sensor type	CCD Progressive
センサーサイズ	Type 2/3
ピクセルサイズ	5.5 μm × 5.5 μm
レンズマウント (標準搭載)	C-Mount
フレームレート (フル解像度)	66 fps
ADC	14 bit
Image buffer (RAM)	128 MByte
	Output
Bit depth	14 (monochrome); 12 (color) bit

Prosilica GX	1660
ビデオフォーマット(Mono)	Mono8, Mono12, Mono12Packed, Mono14
ビデオフォーマット(RGB)	RGB8Packed, BGR8Packed, RGBA8Packed, BGRA8Packed, RGB12Packed
ビデオフォーマット(Raw)	BayerGR8, BayerGR12, BayerGR12Packed
General purpose inputs/outputs (GPIOs)	
Opto-isolated I/Os	2 inputs, 4 outputs
RS232	1
Operating conditions/dimensions	
Operating temperature	0 °C to +50 °C ambient (without condensation)
Power requirements (DC)	10 to 24 VDC
消費電力	5.6 W at 12 VDC (Single GigE Mode); 6.7 W at 12 VDC (Dual GigE Mode)
Mass	269 g
Body dimensions (L × W × H in mm)	107.2 × 53.3 × 33 (including connectors)
Regulations	CE: 2014/30/EU (EMC), 2011/65/EU, including amendment 2015/863/EU (RoHS); FCC Class A; CAN ICES-003

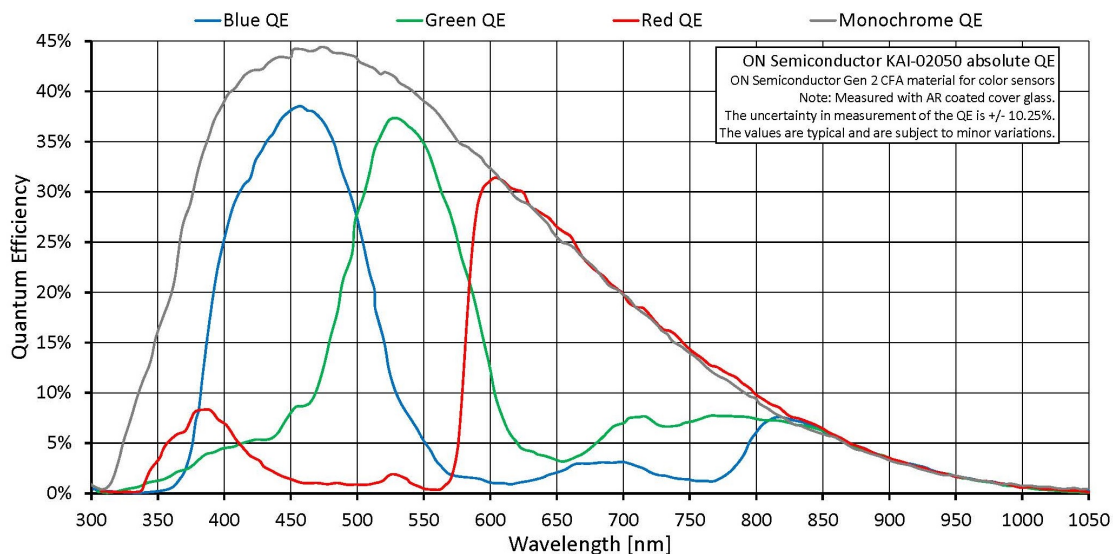

Features

Prosilica GX1660 features include:

- 3-axis motorized lens control



- Video-type auto iris
- Region of interest (ROI), DSP subregion (selectable ROI for auto features)
- Binning (Sum)
- Auto gain (manual gain control: 0 to 34 dB)
- Auto exposure (manual exposure controls: 10 μ s to 26.8 s)
- Auto white balance
- StreamBytesPerSecond (bandwidth control)
- Stream hold
- Sync out modes: Trigger ready, input, exposing, readout, imaging, strobe, GPO
- Global shutter (digital shutter)
- Recorder and Multiframe acquisition modes
- Event channel
- Chunk data
- Storable user set

Technical drawing

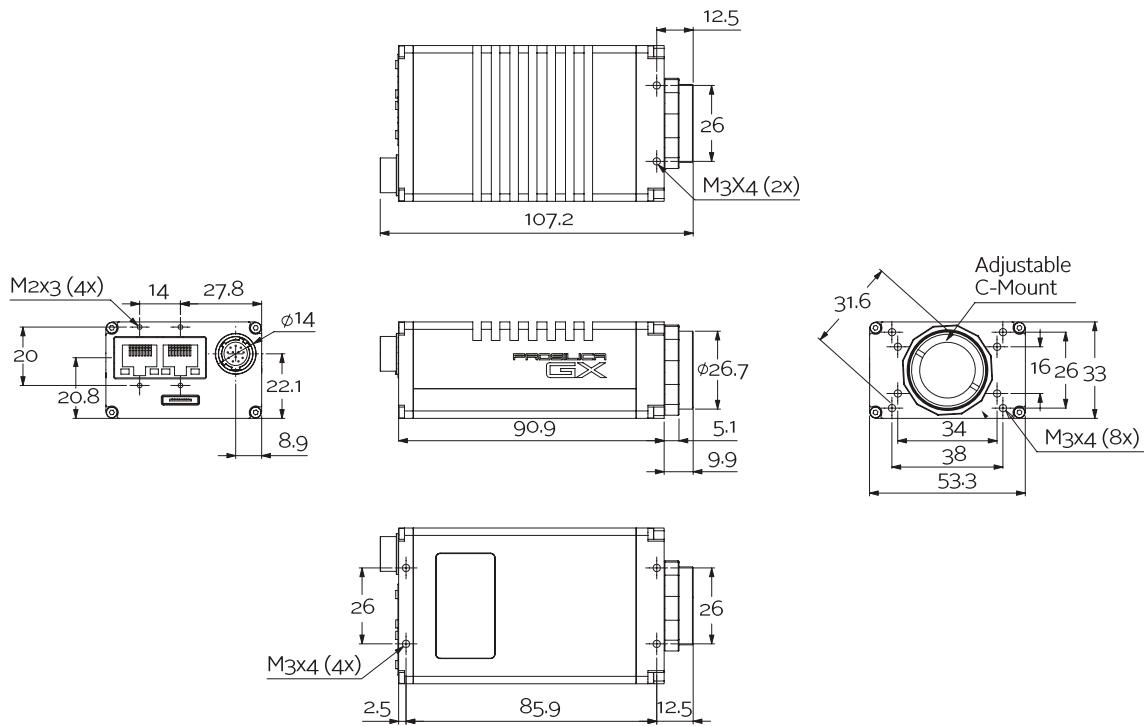



Applications

Prosilica GX1660 is ideal for a wide range of applications including:

- Industrial inspection
- Machine vision
- LCD panel inspection
- Medical imaging
- Ophthalmology
- Aeronautical and aerospace
- Public security
- Surveillance
- Traffic imaging
- OEM applications