

Prosilica GT 2050

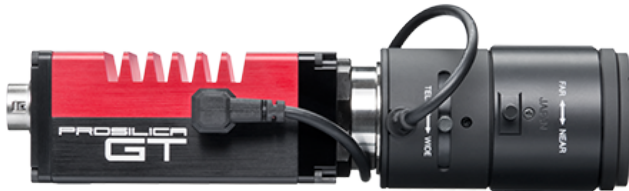

- Versatile temperature range for extreme environments
- IEEE 1588 PTP
- Power over Ethernet
- P-Iris and DC-Iris lens control

Description

4.2 Megapixel machine vision camera with GigE Vision interface

Prosilica GT2050 is a 4.2 Megapixel camera with a GigE Vision compliant Gigabit Ethernet port and Hirose I/O port. Prosilica GT2050 is offered in both monochrome and color models. This camera incorporates the high quality CMOSIS/ams CMV4000 sensor. At full resolution, this camera runs 28.6 frames per second. With a smaller region of interest, higher frame rates are possible. It is a rugged camera designed to operate in extreme environments and fluctuating lighting conditions. This camera offers Precise iris lens control allowing users to fix the aperture size to optimize depth of field, exposure, and gain without the need for additional control elements. By default monochrome models ship with no optical filter and color models ship with an IRC30 IR cut filter.

Benefits and features:

- Monochrome (GT2050) and color (GT2050C) models
- GigE Vision interface with Power over Ethernet
- Screw mount RJ45 Ethernet connector for secure operation in industrial environments
- Supports cable lengths up to 100 meters (CAT-5e or CAT-6)
- Trigger over Ethernet (ToE) Action Commands allow for a single cable solution to reduce system costs
- Comprehensive I/O functionality for simplified system integration
- Popular C-Mount lens mount
- Easy camera mounting via standard M3 threads or optional tripod adapter
- Easy software integration with Allied Vision's [Vimba SDK](#) and compatibility to the most popular [third party image-processing libraries](#).
- Defect pixel masking feature with the Defect Mask Loader tool that allows you to manage a user defined defective pixel list to match your application and optimize the life cycle of the camera.



Options:

- Available with CS-Mount, F-Mount, EF-Mount Birger, M42-Mount
- Available with IR cut filter or protection glass

See the [Modular Concept](#) for lens mount and optical filters options. See the [Customization and OEM Solutions](#) webpage for additional options.

Specifications

Prosilica GT	2050
インターフェイス	IEEE 802.3 1000BASE-T, IEEE 802.3af (PoE)
解像度	2048 (H) × 2048 (V)
センサー	CMOSIS/ams CMV4000
Sensor type	CMOS
センサーサイズ	Type 1
ピクセルサイズ	5.5 μm × 5.5 μm
レンズマウント (標準搭載)	C-Mount
フレームレート (フル解像度)	28.6 fps
ADC	12 bit
Image buffer (RAM)	128 MByte
Output	
Bit depth	8/12 bit
ビデオフォーマット(Mono)	Mono8, Mono12, Mono12Packed
ビデオフォーマット(YUV)	YUV411Packed, YUV422Packed, YUV444Packed
ビデオフォーマット(RGB)	RGB8Packed, BGR8Packed, RGBA8Packed, BGRA8Packed
ビデオフォーマット(Raw)	BayerGB8, BayerGB12, BayerGB12Packed
General purpose inputs/outputs (GPIOs)	
TTL I/Os	1 input, 2 outputs
Opto-isolated I/Os	1 input, 2 outputs
RS232	1
Operating conditions/dimensions	
Operating temperature	-20 °C to +65 °C ambient (without condensation)
Power requirements (DC)	7 to 25 VDC AUX or 802.3at Type 1 PoE
消費電力	3.5 W at 12 VDC; 4.3 W PoE
Mass	210 g
Body dimensions (L × W × H in mm)	86 × 53.3 × 33 (including connectors)

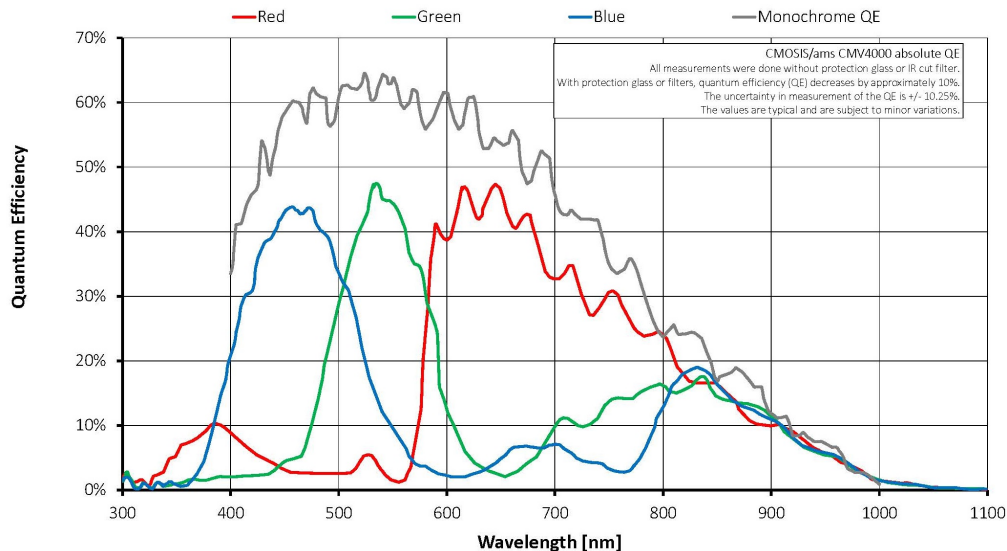

Features

Image optimization features:

- Auto gain (manual gain control: 0 to 26 dB)
- Auto exposure (manual exposure control: 34 μ s to 126.2 s)
- Auto white balance (GT2050C only)
- BlackLevel (offset)
- Color correction, hue, saturation (GT2050C only)
- Defect pixel masking (user defined with Defect Mask Loader tool)
- Gamma correction
- Three look-up tables (LUTs)
- Piecewise Linear HDR mode
- Region of interest (ROI), separate ROI for auto features

Camera control features:

- P-Iris and DC-Iris lens control
- Event channel



- Image chunk data
- IEEE 1588 Precision Time Protocol (PTP)
- RS232
- Storable user sets
- StreamBytesPerSecond (bandwidth control)
- Stream hold
- Sync out modes: Trigger ready, input, exposing, readout, imaging, strobe, GPO
- Temperature monitoring (main board only)
- Trigger over Ethernet (ToE) Action Commands



Applications

Prosilica GT2050 is ideal for a wide range of applications including:

- Outdoor imaging
- Traffic imaging and Intelligent Traffic Systems (ITS)
- Public security and surveillance
- Industrial inspection
- Machine vision
- Military and space applications