

Prosilica GT 1930L



- Versatile temperature range for extreme environments
- IEEE 1588 PTP
- Power over Ethernet
- EF lens control

Description

2.35 Megapixel machine vision camera with Sony IMX CMOS sensor

Prosilica GT1930L is a 2.35 Megapixel camera with a GigE Vision compliant Gigabit Ethernet port and Hirose I/O port. This camera incorporates the high quality Sony IMX174 Exmor CMOS sensor with Pregius global shutter technology providing excellent monochrome and color image quality. At full resolution, this camera runs 50.7 frames per second. With a smaller region of interest, higher frame rates are possible. It is a rugged camera designed to operate in extreme environments. This camera ships with a planarity adjustable EF-Mount as standard. By default monochrome models ship with no optical filter and color models ship with an IRC30 IR cut filter.

Benefits and features:

- Monochrome (GT1930L) and color (GT1930LC) models
- GigE Vision interface with Power over Ethernet
- Screw mount RJ45 Ethernet connector for secure operation in industrial environments
- Supports cable lengths up to 100 meters (CAT-5e or CAT-6)
- The Sony IMX174 Exmor is a high sensitivity CMOS sensor
- Trigger over Ethernet (ToE) Action Commands allow for a single cable solution to reduce system costs
- Comprehensive I/O functionality for simplified system integration
- Planarity adjustable (PA) EF Lens Mount for electronic control of aperture and autofocus
- Easy camera mounting via standard M3 threads at all sides and 1/4-20 tripod mounting hole
- Easy software integration with Allied Vision's [Vimba SDK](#) and compatibility to the most popular [third party image-processing libraries](#).



Options:

- Available with F-Mount PA, M58-Mount, M58-Mount PA, M42-Mount, M42-Mount PA
- Available with IRC30 IR cut filter, IRC Filter Schneider 486, or Protection Glass B 270 (ASG)

See the [Modular Concept](#) for lens mount and optical filters options. See the [Customization and OEM Solutions](#) webpage for additional options.

Specifications

Prosilica GT	1930L
インターフェイス	IEEE 802.3 1000BASE-T, IEEE 802.3af (PoE)
解像度	1936 (H) × 1216 (V)
センサー	Sony IMX174
Sensor type	CMOS
センサーサイズ	Type 1/1.2
ピクセルサイズ	5.86 μm × 5.86 μm
レンズマウント (標準搭載)	EF-Mount
フレームレート (フル解像度)	50.7 fps
ADC	12 bit
Image buffer (RAM)	128 MByte
Output	
Bit depth	12 bit
ビデオフォーマット(Mono)	Mono8, Mono12Packed, Mono12
ビデオフォーマット(YUV)	YUV411Packed, YUV422Packed, YUV444Packed
ビデオフォーマット(RGB)	RGB8Packed, BGR8Packed
ビデオフォーマット(Raw)	BayerRG8, BayerRG12, BayerRG12Packed
General purpose inputs/outputs (GPIOs)	
TTL I/Os	1 input, 2 outputs
Opto-isolated I/Os	1 input, 2 outputs
RS232	1
Operating conditions/dimensions	
Operating temperature	-30 °C to +70 °C housing (without condensation)
Power requirements (DC)	7 to 25 VDC AUX or 802.3at Type 1 PoE
消費電力	3.24 W at 12 VDC; 3.88 W PoE
Mass	372 g
Body dimensions (L × W × H in mm)	96 × 66 × 53.3 (including connectors)
Regulations	CE: 2014/30/EU (EMC), 2011/65/EU, including amendment 2015/863/EU (RoHS); FCC Class A; CAN ICES-003 Issue 4/5

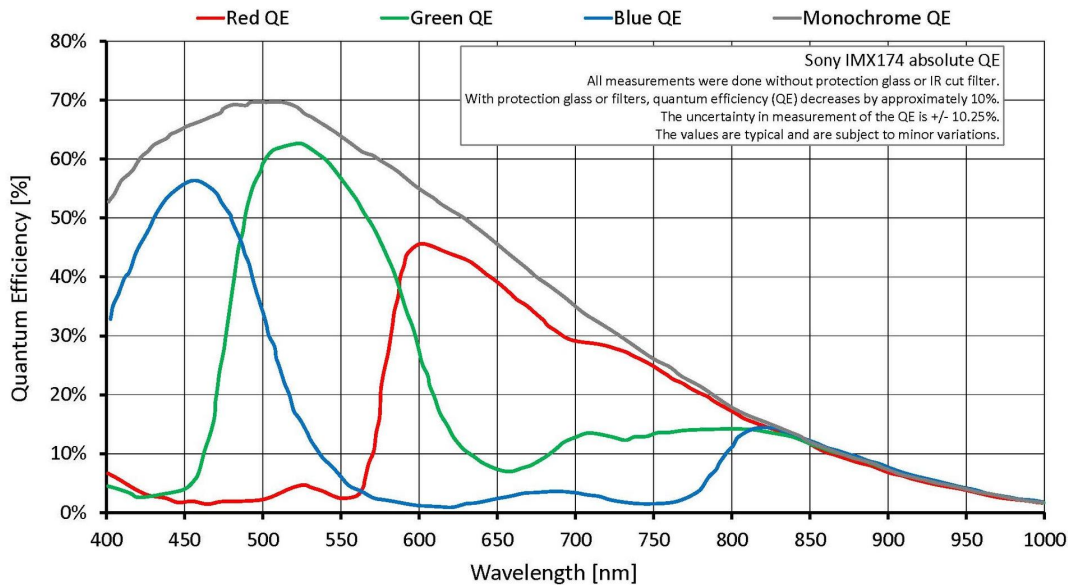

Features

Image optimization features:

- Auto gain (manual gain control: 0 to 40 dB; 0.1 dB increments)
- Auto exposure (exposure time control varies by per pixel format)
- Auto white balance (GT1930LC only)
- Binning (horizontal and vertical)
- BlackLevel (offset)
- Color correction, hue, saturation (GT1930LC only)
- Decimation X/Y
- Gamma correction
- Three look-up tables (LUTs)
- Region of interest (ROI), separate ROI for auto features
- Reverse X/Y

Camera control features:

- EF lens control
- Event channel
- Image chunk data
- IEEE 1588 Precision Time Protocol (PTP)
- RS232
- Storable user sets
- StreamBytesPerSecond (bandwidth control)

- Stream hold
- Sync out modes: Trigger ready, input, exposing, readout, imaging, strobe, GPO
- Temperature monitoring (sensor board and main board)
- Trigger over Ethernet (ToE) Action Commands

Technical drawing

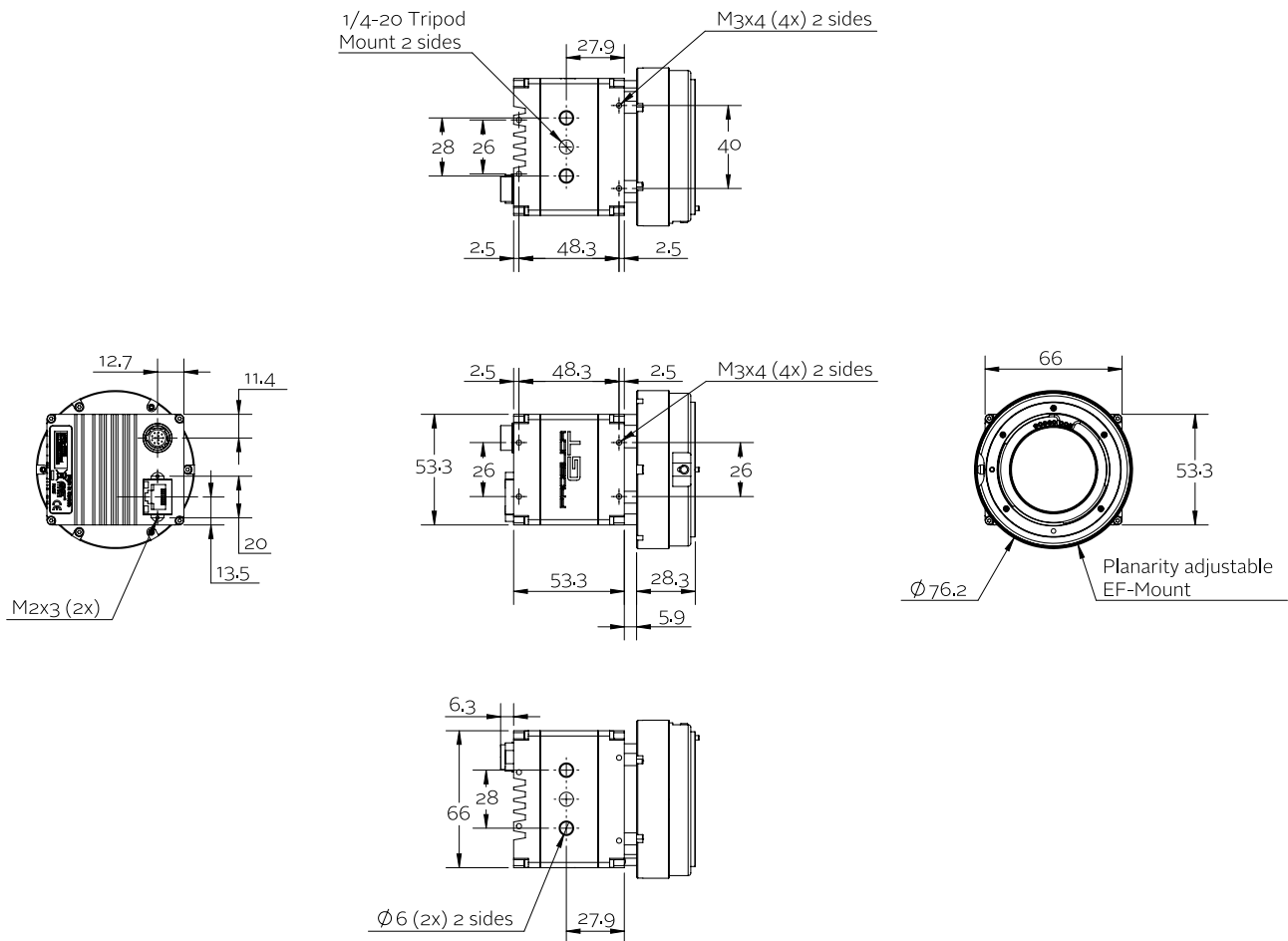



Applications

Prosilica GT1930L is ideal for a wide range of applications including:

- Outdoor imaging
- Traffic imaging and Intelligent Traffic Systems (ITS)
- Public security and surveillance
- Industrial inspection
- Machine vision
- Military and space applications