

Prosilica GE 4900



- 16 Megapixel camera
- ON Semi KAI-16000 sensor
- Galvanically isolated I/O
- Various lens mount options

Description

ON Semi KAI-16000 16 Megapixel CCD camera, 3 frames per second

Prosilica GE4900 is a very high resolution CCD camera with Gigabit Ethernet output (GigE Vision). This camera features the high-quality 35 mm optical format ON Semiconductor KAI-16000 CCD image sensor that provides exceptionally high resolution and good sensitivity. At full resolution, this camera has a frame rate of 3 frames per second. With a smaller region of interest higher frame rates are possible. By default monochrome models ship with no optical filter and color models ship with an IRC30 IR cut filter.

Specifications

Prosilica GE	4900
インターフェイス	IEEE 802.3 1000baseT
解像度	4872 (H) × 3248 (V)
センサー	ON Semi KAI-16000
Sensor type	CCD Progressive
センサーサイズ	Type 35 mm
ピクセルサイズ	7.4 μm × 7.4 μm
レンズマウント (標準搭載)	F-Mount
フレームレート (フル解像度)	3 fps
ADC	12 bit
Image buffer (RAM)	32 MByte
	Output
Bit depth	8/12 bit
ビデオフォーマット(Mono)	Mono8, Mono12, Mono12Packed

Prosilica GE	4900
ビデオフォーマット(Raw)	BayerGR8, BayerGR12, BayerGR12Packed
General purpose inputs/outputs (GPIOs)	
TTL I/Os	1 input, 3 outputs (with galvanic isolation)
RS232	1
Operating conditions/dimensions	
Operating temperature	0 °C to +50 °C ambient (without condensation)
Power requirements (DC)	5 to 24 VDC
消費電力	6 W at 12 VDC
Mass	402 g
Body dimensions (L × W × H in mm)	110 × 66 × 66 (including connectors)
Regulations	2011/65/EU, including amendment 2015/863/EU (RoHS)

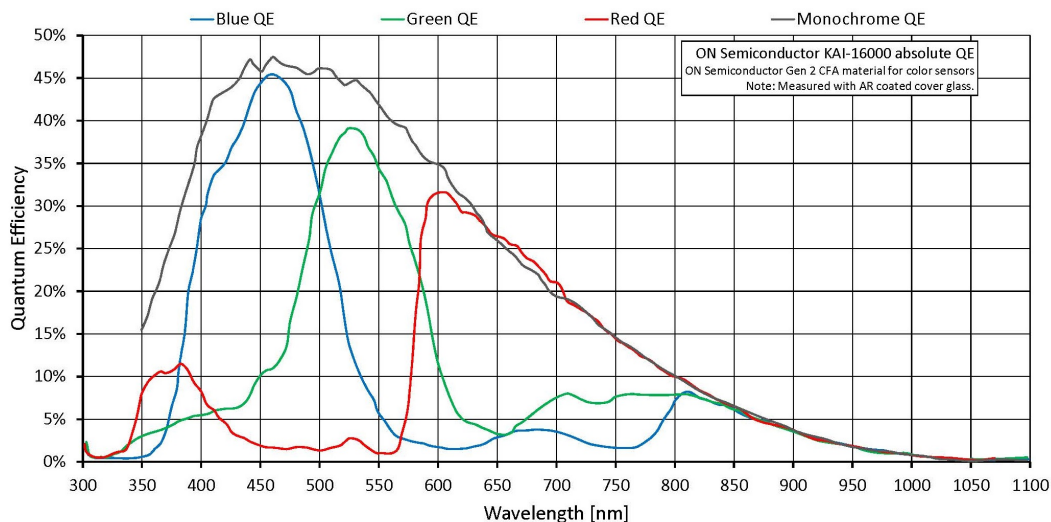

Features

Prosilica GE4900 features include:

- Defect masking for columns
- Region of interest (ROI), DSP subregion (selectable ROI for auto features)
- Binning (Sum)
- Auto gain (manual gain control: 0 to 34 dB)
- Auto exposure (manual exposure controls: 625 μ s to 68.7 s)
- Auto white balance



- StreamBytesPerSecond (bandwidth control)
- Stream hold
- Sync out modes: Trigger ready, input, exposing, readout, imaging, strobe, GPO
- Global shutter (digital shutter)
- Recorder and Multiframe acquisition modes
- Event channel
- Image chunk data
- Storable user sets

Technical drawing

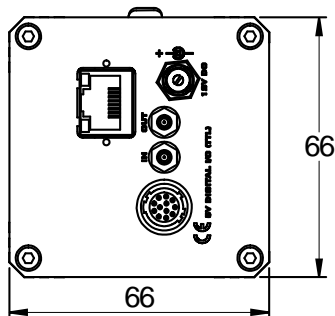
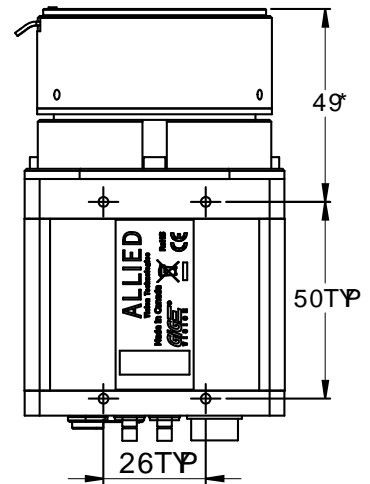
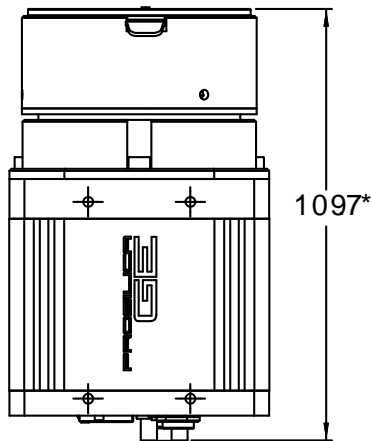
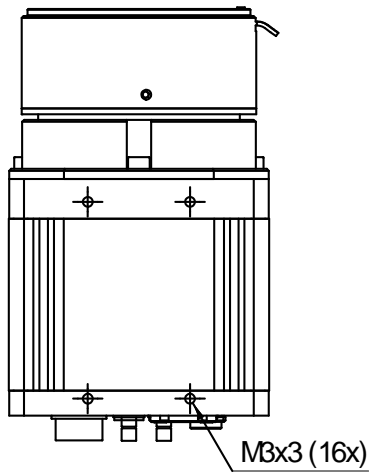
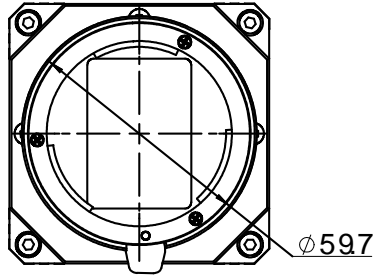

* Nominal value Add 0.3mm for color cameras.



Applications

Prosilica GE4900 is ideal for a wide range of applications including:

- LCD panel inspection
- Semiconductor wafer inspection
- Solar panel inspection
- High-resolution industrial inspection
- Aerial photography
- 3D metrology
- General machine vision
- Public security
- Surveillance
- Traffic imaging (Intelligent Traffic Systems)
- Embedded systems
- OEM applications