



## Pike F-100



- Versatile IEEE 1394b camera
- Advanced feature set
- Many variants
- High frame rates

### Description

#### Premium 1 Megapixel FireWire camera with very high frame rates

The Pike F-100B/F-100C is equipped with an ON Semiconductor KAI-1020 CCD sensor. At full resolution, it runs at 60 frames per second (Mono8/Raw8). Higher frame rates can be reached by using a smaller area of interest (AOI), binning (b/w), or sub-sampling. The camera includes extraordinary image pre-processing functions like the High SNR mode (up to 24 dB better signal-to-noise ratio).

Options:

- IEEE 1394b connectors: 2 x copper (daisy chain) or 1 x GOF, 1 x copper, Hirose power: out
- Various IR cut/pass filters, various lens mounts
- Angled head, white medical housing

### Specifications

Pike	F-100
インターフェイス	IEEE 1394b - 800 Mb/s, 2 ports, daisy chain, fiber optic (GOF) optional
解像度	1000 (H) × 1000 (V)
センサー	ON Semi KAI-1020
Sensor type	CCD Progressive
センサーサイズ	Type 2/3
ピクセルサイズ	7.4 μm × 7.4 μm
レンズマウント (標準搭載)	C-Mount
フレームレート (フル解像度)	60 fps
ADC	14 bit

Pike	F-100
Image buffer (RAM)	64 MByte
Output	
Bit depth	8-14 bit
ビデオフォーマット(Mono)	Mono8, Mono12, Mono16
ビデオフォーマット(RGB)	RGB8
ビデオフォーマット(Raw)	Raw8, Raw12, Raw16
General purpose inputs/outputs (GPIOs)	
Opto-isolated I/Os	2 inputs, 4 outputs
RS232	1
Operating conditions/dimensions	
Operating temperature	+5 °C to +50 °C
Power requirements (DC)	8 V to 36 V
消費電力	4 W (@ 12 VDC)
Mass	250 g
Body dimensions (L × W × H in mm)	96.8 × 44 × 44 (including connectors)
Regulations	CE: 2014/30/EU (EMC), 2011/65/EU (RoHS); FCC Class B

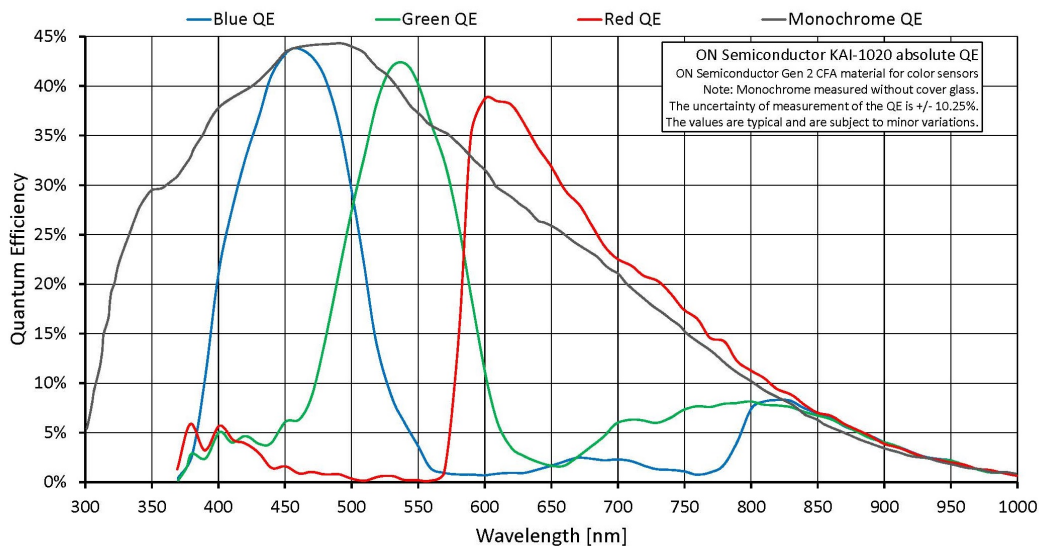

## Features

- High SNR mode (up to 24 dB better signal-to-noise ratio)
- Low-Noise Binning Mode
- Smear reduction



- Shading correction
- Area of interest (AOI), separate AOI for auto features
- Binning
- Decimation
- Auto gain (manual gain control: 0 to 22 dB)
- Auto exposure (43  $\mu$ s to 67 s)
- Auto white balance
- Look-up table (LUT)
- Hue, saturation, color correction
- Reverse X
- Deferred image transport
- Trigger programmable, level, single, bulk, programmable delay
- Sequence mode (changes the camera settings on the fly)
- SIS (secure image signature, time stamp for trigger, frame count etc.)
- Storable user sets

## Technical drawing





## Applications

The Pike F-100B/F-100C is a 1 Megapixel camera for sophisticated requirements. OEM customers profit from its modular design, which provides many opportunities for customization. For Healthcare and Life science applications, a white housing (medical design) is available (this applies to all cameras by Allied Vision Technologies).

Pike cameras are especially suited for:

- Applications which require high frame rates and outstanding image quality
- OEM applications (modular concept)
- 3D recordings
- Science and research
- Healthcare and sports
- Multimedia and entertainment
- Intelligent traffic solutions (ITS)
- Long cable lengths, 400 meters and more (fiber version)