

Mako G G-419B NIR



- CMOSIS/ams NIR enhanced sensor
- Power over Ethernet
- Ultra-compact design
- Affordable

Description

CMOSIS/ams CMV4000 sensor, NIR optimized, global shutter

Mako G-419B NIR is a 4.2 megapixel GigE machine vision camera that incorporates the high quality Type 1 (16.0 mm diagonal) CMOSIS/ams CMV4000 CMOS NIR enhanced sensor. At full resolution, this camera runs 26.3 frames per second. With a smaller region of interest, higher frame rates are possible.

Mako G cameras have an ultra-compact form factor and the same mounting positions as many analog cameras. All models include Power over Ethernet (PoE), three opto-isolated outputs, and a 64 MB image buffer. The image quality profits from the precisely aligned sensor. By default NIR models ship with no optical filter.

Benefits and features:

- GigE Vision interface with Power over Ethernet
- Screw mount RJ45 Ethernet connector for secure operation in industrial environments
- Supports cable lengths up to 100 meters (CAT-5e or CAT-6)
- Comprehensive I/O functionality for simplified system integration
- Popular C-Mount lens mount
- Easy camera mounting via standard M3 threads on top and bottom of housing or optional tripod adapter
- Easy software integration with Allied Vision's [Vimba SDK](#) and compatibility to the most popular [third party image-processing libraries](#).

Options:

- Available with CS-Mount or M12-Mount adapter
- Available with Protection glass B 270 (ASG), IRC type Jenofilt 217 (IR cut filter), IRC Hoya C-5000 (IR cut filter), IRP RG715 (IR pass filter), IRP RG830 (IR pass filter)



See the [Modular Concept](#) for lens mount and optical filter options.
 See the [Customization and OEM Solutions](#) webpage for additional options.

Specifications

Mako G	G-419B NIR
インターフェイス	IEEE 802.3 1000BASE-T, IEEE 802.3af (PoE)
解像度	2048 (H) × 2048 (V)
センサー	CMOSIS/ams CMV4000 NIR
Sensor type	CMOS
センサーサイズ	Type 1
ピクセルサイズ	5.5 μm × 5.5 μm
レンズマウント (標準搭載)	C-Mount
フレームレート (フル解像度)	26.3 fps
ADC	12 bit
Image buffer (RAM)	64 MByte
Output	
Bit depth	8/12 bit
ビデオフォーマット(Mono)	Mono8, Mono12, Mono12Packed
General purpose inputs/outputs (GPIOs)	
Opto-isolated I/Os	1 input, 3 outputs
Operating conditions/dimensions	
Operating temperature	+5 °C to +45 °C housing temperature
Power requirements (DC)	12 to 24 VDC; PoE
消費電力	2.3 W at 12 VDC; 2.7 W PoE
Mass	80 g
Body dimensions (L × W × H in mm)	60.5 × 29.2 × 29.2 (including connectors)
Regulations	CE: 2014/30/EU (EMC), 2011/65/EU, including amendment 2015/863/EU (RoHS); FCC Class B; CAN ICES-003

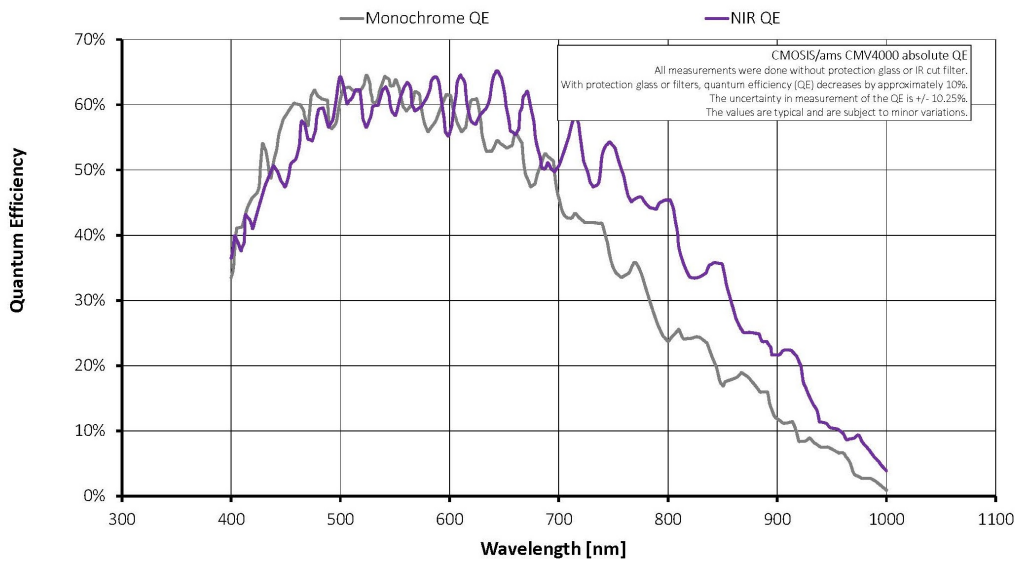

Features

Image optimization features:

- Auto gain (manual gain control: 0 to 26 dB; 1 dB increments)
- Auto exposure (manual exposure control: 41 μ s to 153 s; 1 μ s increments)
- Defect masking
- Gamma correction
- One look-up table (LUT)
- Piecewise Linear HDR mode
- Region of interest (ROI), separate ROI for auto features

Camera control features:

- Event channel
- Image chunk data
- Storable user sets
- StreamBytesPerSecond (bandwidth control)
- Stream hold
- Sync out modes: Trigger ready, input, exposing, readout, imaging, strobe, GPO
- Temperature monitoring (main board only)

Technical drawing

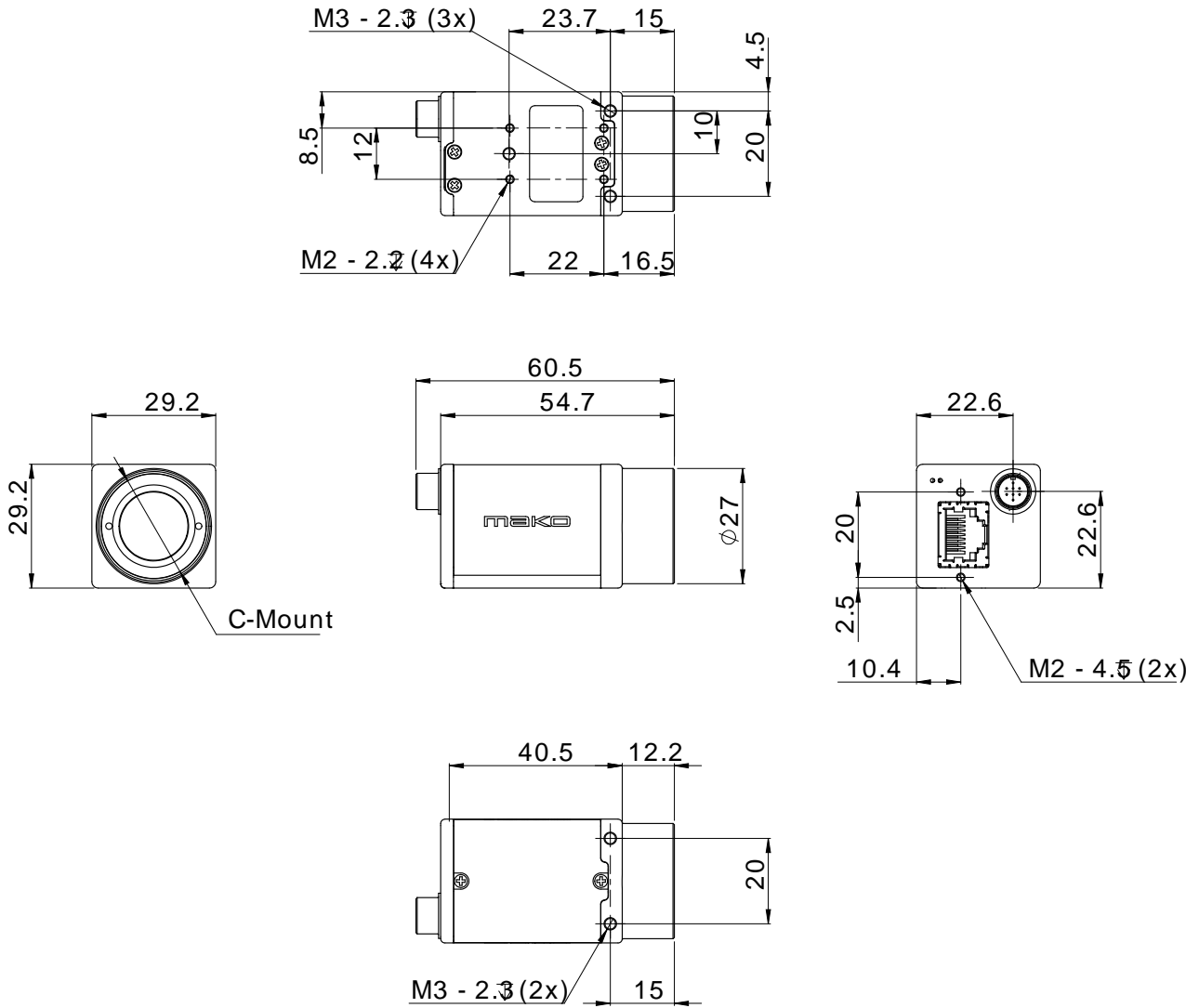



Applications

Mako G-419B NIR is suitable for a wide range of applications including:

- Robotics
- Quality control
- Inspection, surveillance
- Industrial imaging
- Machine vision
- Logistics