

Prosilica GE

680



- High frame rate
- ON Semi KAI-0340 sensor
- Galvanically isolated I/O
- Various lens mount options

For speed and good sensitivity

Compact, high performance CCD machine vision cameras with GigE Vision

Prosilica GE 680 with ON Semi KAI-0340 runs 205.0 frames per second at 0.3 MP resolution.

Prosilica GE cameras are very compact, high-performance machine vision cameras with Gigabit Ethernet interface (GigE Vision®).

The GigE interface allows for very fast frame rates and long cable lengths.

- Compact size
- VGA to 16 Megapixel resolution
- Fast frame rates to 205 fps
- OnSemi KAI CCD sensors
- Modular options available

Specifications

Interface	IEEE 802.3 1000baseT
Resolution	640 (H) × 480 (V)
Sensor	ON Semi KAI-0340
Sensor type	CCD Progressive
Sensor size	Type 1/3
Pixel size	7.4 μm × 7.4 μm
Lens mount (default)	C-Mount
Max. frame rate at full resolution	205 fps
ADC	12 Bit
Image buffer (RAM)	32 MByte

Output

Bit depth	8-bit or 12-bit
Monochrome pixel formats	Mono8, Mono12, Mono12Packed
YUV color pixel formats	YUV411Packed
RGB color pixel formats	RGB8Packed, BGR8Packed, RGBA8Packed, BGRA8Packed, RGB12Packed
Raw pixel formats	BayerGR8, BayerGR12, BayerGR12Packed

General purpose inputs/outputs (GPIOs)

TTL I/Os	1 input, 3 outputs (with galvanic isolation)
RS232	1

Operating conditions/dimensions

Operating temperature	0 °C to +50 °C ambient (without condensation)
Power requirements (DC)	5 to 24 VDC
Power consumption	4.5 W at 12 VDC
Mass	169 g
Body dimensions (L × W × H in mm)	80 × 51 × 39 (including connectors)

Quantum efficiency

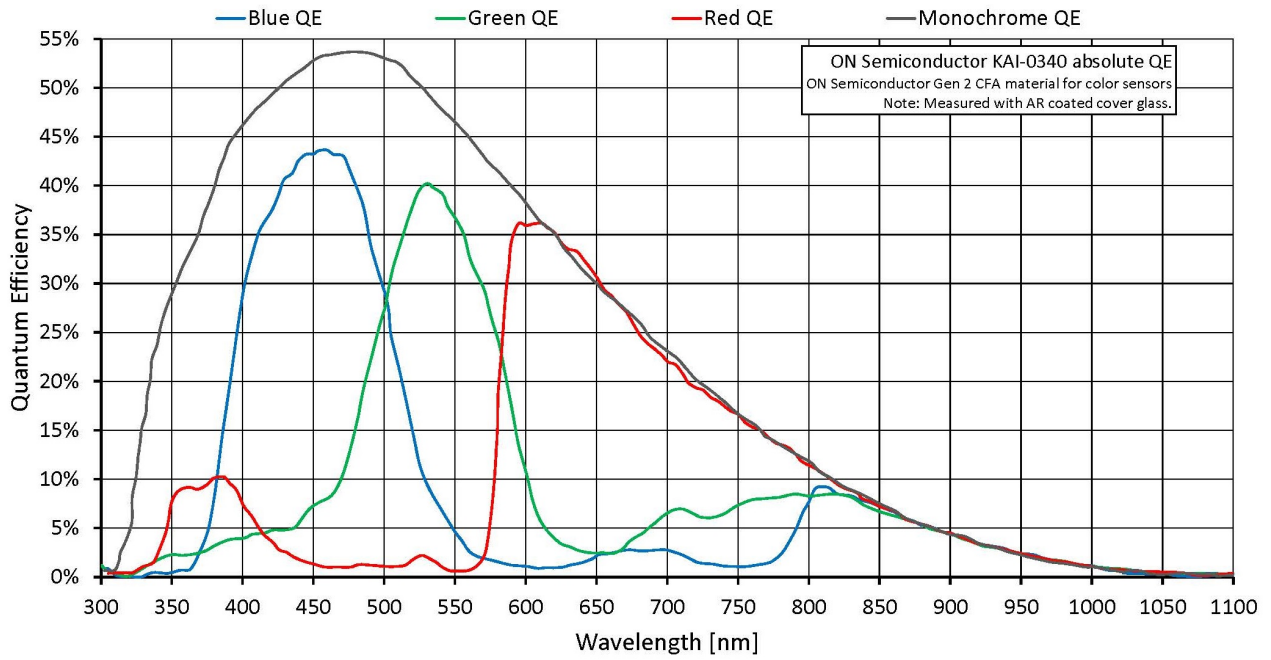

Features

Prosilica GE680 incorporates an advanced set of camera features including:

- Region of interest (ROI), DSP subregion (selectable ROI for auto features)
- Binning (Sum)
- Auto gain (manual gain control: 0 to 34 dB)
- Auto exposure (manual exposure controls: 25 μ s to 53.7 s)
- Auto white balance
- StreamBytesPerSecond (bandwidth control)
- Stream hold
- Sync out modes: Trigger ready, input, exposing, readout, imaging, strobe, GPO
- Global shutter (digital shutter)
- Recorder and Multiframe acquisition modes
- Event channel
- Image chunk data
- Storable user sets

Technical drawing

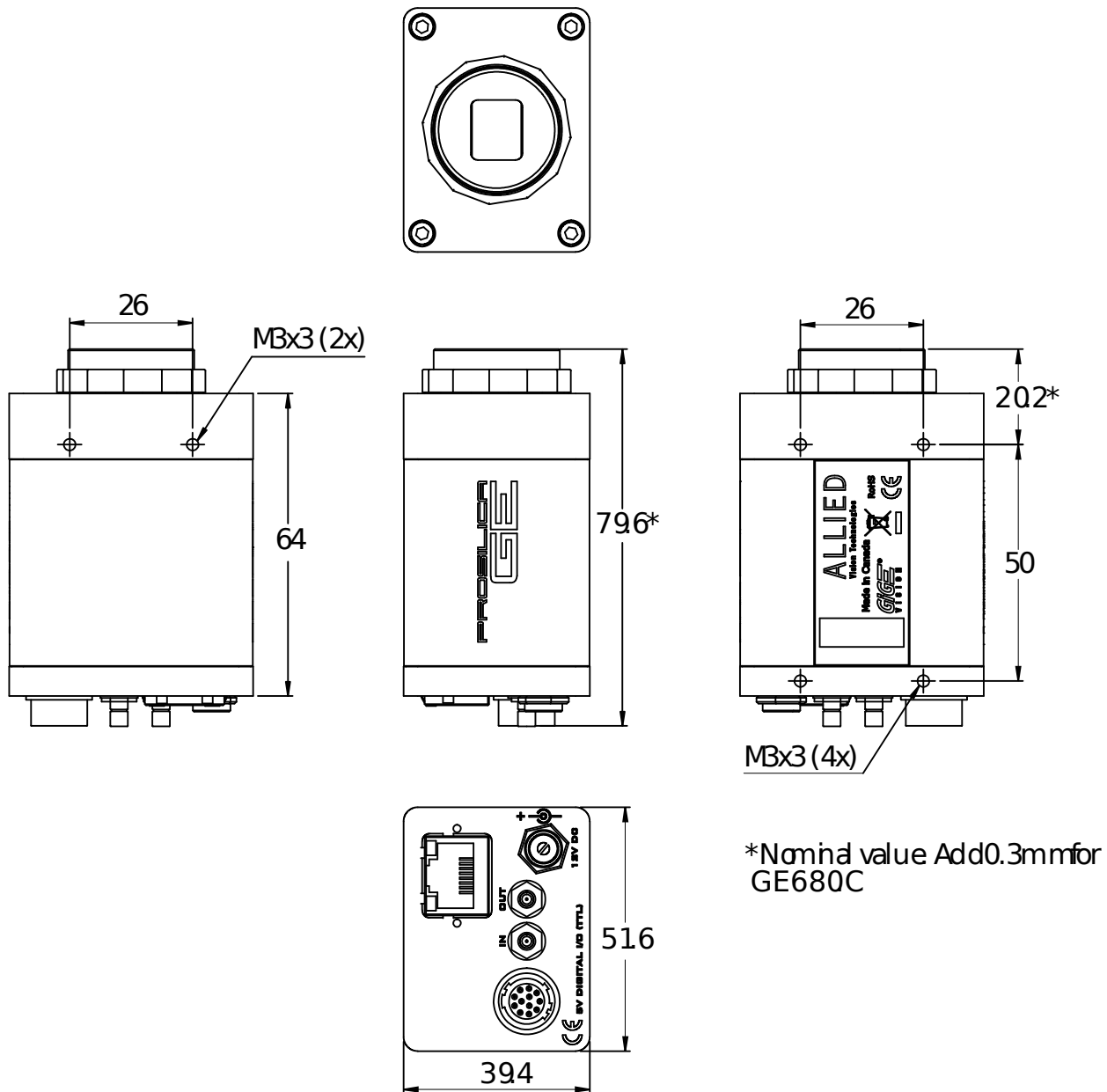

Applications

Prosilica GE680 is ideal for a wide range of applications including:

- High-speed inspection
- Machine vision
- Optical character recognition
- Traffic imaging
- Robotics

- OEM applications