



Stingray

F-125



- Versatile 1.2 MP camera
- Advanced feature set
- Many variants
- Excellent image quality

Description

Industrial camera, Sony EXview HAD CCD sensor ICX445

The Stingray F-125B/F-125C is equipped with the Sony EXview HAD ICX445 CCD sensor and has an extra high sensitivity. At full resolution, it runs at 30 frames per second. Higher frame rates can be reached by using a smaller area of interest (AOI), binning (b/w) or sub-sampling.

Options:

- IEEE 1394b connectors: 2 x copper (daisy chain), Hirose power: out
- Various IR cut/pass filters, various lens mounts
- Angled head, board level version, white medical housing

Specifications

Stingray	F-125
Interface	IEEE 1394b - 800 Mb/s, 2 ports, daisy chain
Resolution	1292 (H) × 964 (V)
Sensor	Sony ICX445
Sensor type	CCD Progressive
Cell size	3.75 μm x 3.75 μm
Lens mount	C-Mount
Max frame rate at full resolution	30 fps
ADC	14 bit
Image buffer (RAM)	Up to 128 MByte
	Output
Bit depth	8-14 bit

Stingray	F-125
Mono modes	Mono8, Mono12, Mono16
Color modes RGB	RGB8
Raw modes	Raw8, Raw12, Raw16
General purpose inputs/outputs (GPIOs)	
Opto-isolated I/Os	2 inputs, 4 outputs
RS-232	1
Operating conditions/dimensions	
Operating temperature	+5 °C to +45 °C
Power requirements (DC)	8 V to 36 V
Power consumption (@12 V)	<4 W
Mass	92 g
Body dimensions (L × W × H in mm)	72.9 × 44 × 29 (including connectors)
Regulations	CE, RoHS, REACH, WEEE, FCC, ICES

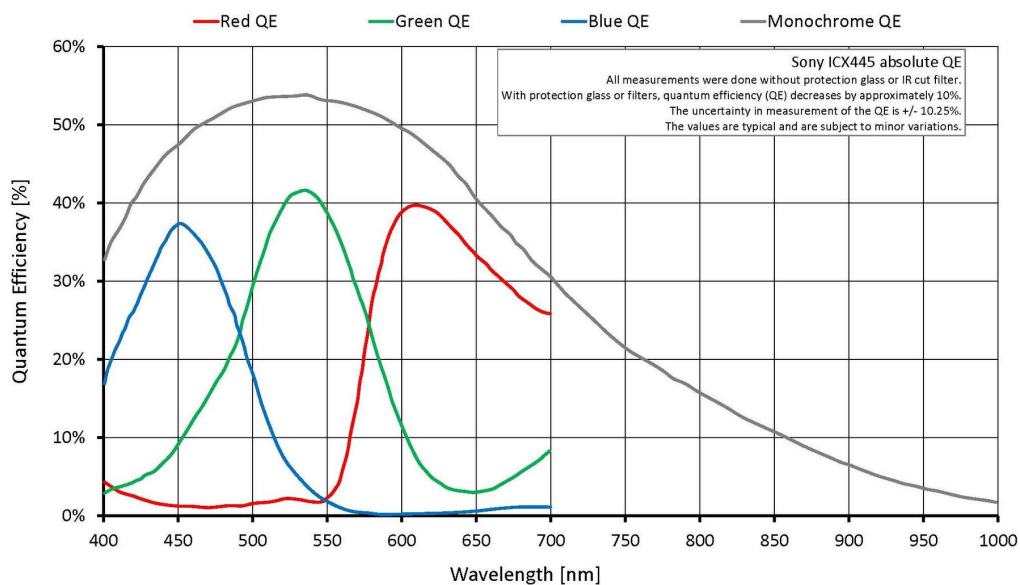

Features

- High SNR mode (up to 24 dB better signal-to-noise ratio)
- Low-noise binning mode
- Shading correction
- Defect pixel correction
- Area of interest (AOI), separate AOI for auto features
- Binning
- Decimation



- Auto gain (manual gain control: 0 to 24.4 dB)
- Auto exposure (25 μ s to 67 s)
- Auto white balance
- Look-up table (LUT)
- Hue, saturation
- Color correction
- Local color anti-aliasing
- Reverse X/Y
- Deferred image transport
- Trigger programmable, level, single, bulk, programmable delay
- Sequence mode (changes the camera settings on the fly)
- SIS (secure image signature, time stamp for trigger, frame count etc.)
- Storable user sets

Scope of delivery

- Camera and IEEE 1394b cable (other configurations on request)

Technical drawing

2 x 1394b copper

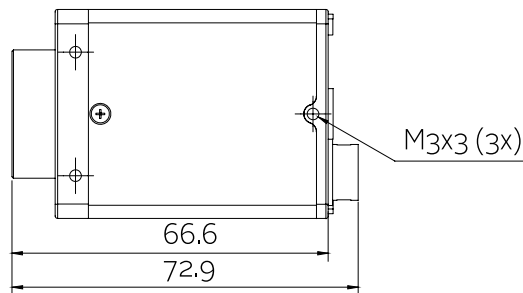
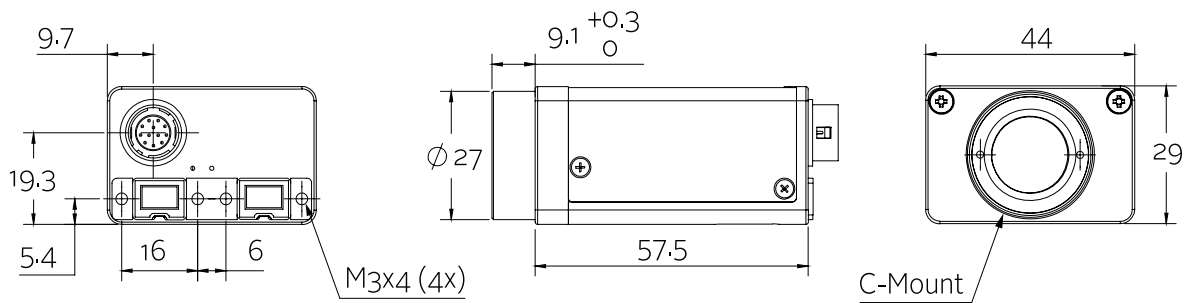
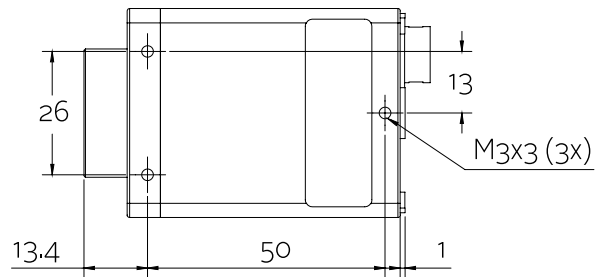



Applications

Stingray F-125B/F-125C cameras incorporate the Sony ExView ICX445 HAD sensor (very high sensitivity). Furthermore, its smart functions like the High SNR mode enhance the image quality especially in low light situations. This industrial camera is ideally suited for:

- Industrial inspection and automation
- Logistics
- Science and research
- Healthcare and medical (white housing available)
- Multimedia, entertainment and sports
- Intelligent traffic solutions (ITS)

Additionally, it is ideally suited for:

- Demanding OEM camera applications (board level versions with separate sensor board available on request)
- Daisy chaining (two copper connectors)