

Prosilica GT

1380



- Versatile temperature range for extreme environments
- IEEE 1588 PTP
- Power over Ethernet
- P-Iris and DC-Iris lens control

Description

1.4 Megapixel machine vision camera for extreme environments

Prosilica GT1380 is a 1.4 Megapixel camera with a GigE Vision compliant Gigabit Ethernet port and Hirose I/O port. Prosilica GT1380 is offered in both monochrome and color models. This camera incorporates the high quality Type 2/3 (11.0 mm diagonal) Sony ICX285 CCD sensor with EXview HAD CCD technology providing high-sensitivity, low noise, excellent anti-blooming, and superb image quality. At full resolution, this camera runs 30.5 frames per second. With a smaller region of interest, higher frame rates are possible. It is a robust camera designed to operate in extreme environments and fluctuating lighting conditions. This camera offers Precise iris lens control allowing users to fix the aperture size to optimize depth of field, exposure, and gain without the need for additional control elements. By default monochrome models ship with no optical filter and color models ship with an IRC30 IR cut filter.

Benefits and features:

- Monochrome (GT1380) and color (GT1380C) models
- GigE Vision interface with Power over Ethernet
- Screw mount RJ45 Ethernet connector for secure operation in industrial environments
- Supports cable lengths up to 100 meters (CAT-5e or CAT-6)
- Trigger over Ethernet (ToE) Action Commands allow for a single cable solution to reduce system costs
- Comprehensive I/O functionality for simplified system integration
- Popular C-Mount lens mount
- Easy camera mounting via standard M3 threads or optional tripod adapter
- Easy software integration with Allied Vision's [Vimba SDK](#) and compatibility to the most popular [third party image-processing libraries](#).

Options:

- Available with CS-Mount, F-Mount, EF-Mount Birger, M42-Mount



- Available with IR cut filter or protection glass

See the [Modular Concept](#) for lens mount and optical filters options. See the [Customization and OEM Solutions](#) webpage for additional options.

Specifications

Prosilica GT	1380
Interface	IEEE 802.3 1000BASE-T, IEEE 802.3af (PoE)
Resolution	1360 (H) × 1024 (V)
Sensor	Sony ICX285
Sensor type	CCD Progressive
Sensor size	Type 2/3
Pixel size	6.45 μm × 6.45 μm
Lens mount (default)	C-Mount
Max. frame rate at full resolution	30.5 fps
ADC	14 bit
Image buffer (RAM)	128 MByte
Output	
Bit depth	12/14 bit
Monochrome pixel formats	Mono8, Mono12, Mono12Packed, Mono14
YUV color pixel formats	YUV411Packed, YUV422Packed, YUV444Packed
RGB color pixel formats	RGB8Packed, BGR8Packed
Raw pixel formats	BayerRG8, BayerRG12, BayerRG12Packed
General purpose inputs/outputs (GPIOs)	
TTL I/Os	1 input, 2 outputs
Opto-isolated I/Os	1 input, 2 outputs
RS232	1
Operating conditions/dimensions	
Operating temperature	-20 °C to +65 °C ambient (without condensation)
Power requirements (DC)	7 to 25 VDC; PoE
Power consumption	3.4 W at 12 VDC; 4.2 W PoE
Mass	211 g
Body dimensions (L × W × H in mm)	86 × 53.3 × 33 (including connectors)
Regulations	CE: 2014/30/EU (EMC), 2011/65/EU, including amendment 2015/863/EU (RoHS); FCC Class A; CAN ICES-003 Issue 4/5

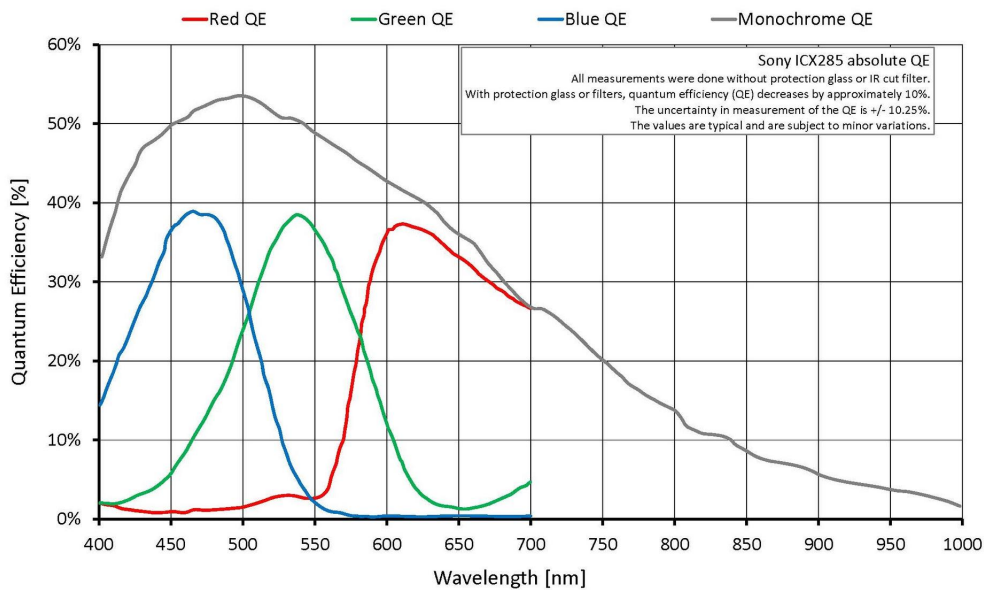

Features

Image optimization features:

- Auto gain (manual gain control: 0 to 34 dB; 1 dB increments)
- Auto exposure (manual exposure control: 10 μ s to 77.3 s; 1 μ s increments)
- Auto white balance (GT1380C only)
- Binning (horizontal and vertical)
- Color correction, hue, saturation (GT1380C only)
- Decimation X/Y
- Gamma correction
- Three look-up tables (LUTs)
- Region of interest (ROI), separate ROI for auto features

Camera control features:

- P-Iris and DC-Iris lens control
- Event channel
- Image chunk data
- IEEE 1588 Precision Time Protocol (PTP)
- RS232
- Storable user sets
- StreamBytesPerSecond (bandwidth control)
- Stream hold
- Sync out modes: Trigger ready, input, exposing, readout, imaging, strobe, GPO

- Temperature monitoring (main board and sensor board)
- Trigger over Ethernet (ToE) Action Commands

Technical drawing

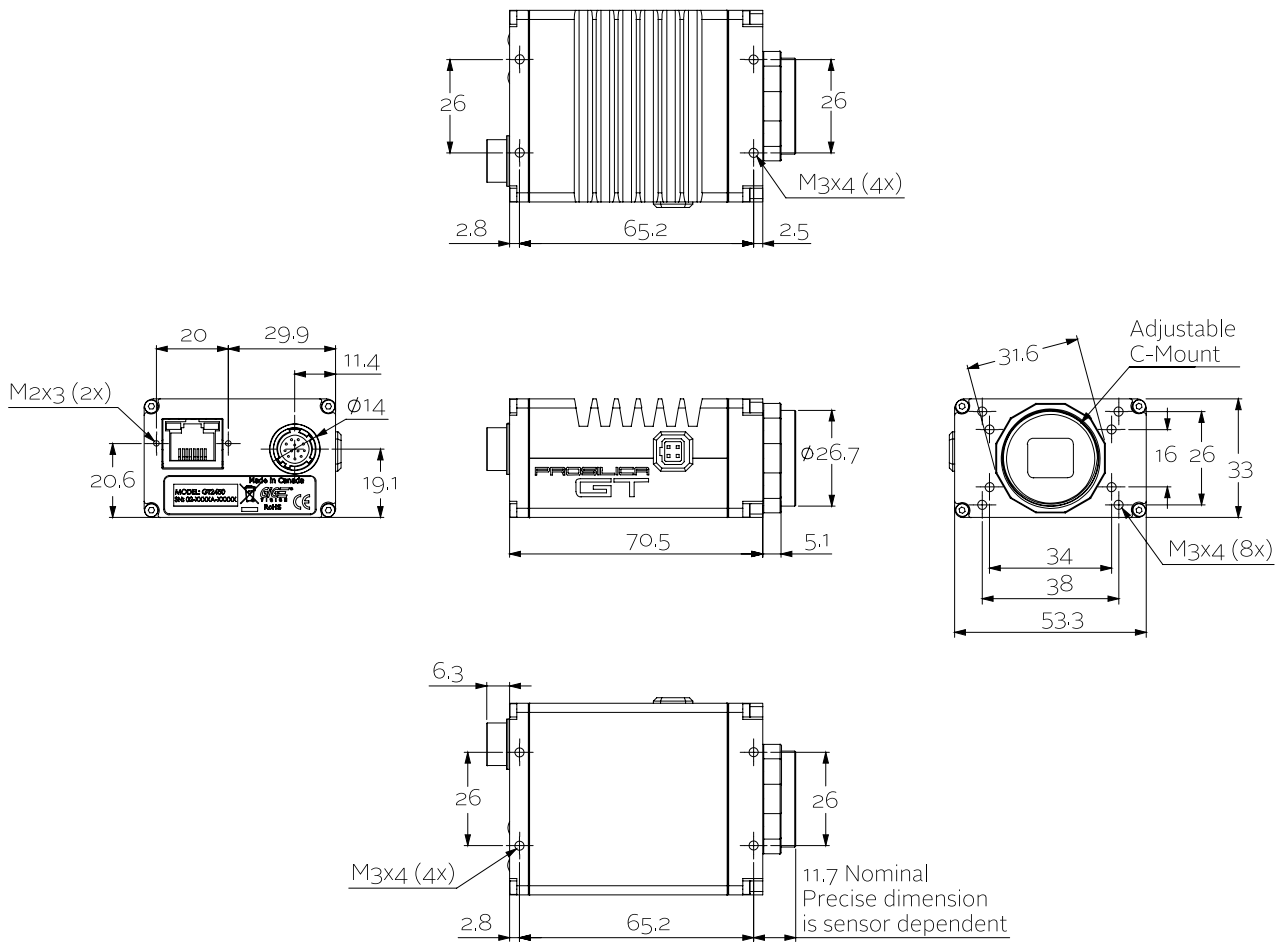



Applications

Prosilica GT1380 is ideal for a wide range of applications including:

- Outdoor imaging
- Traffic imaging and Intelligent Traffic Systems (ITS)
- Public security and surveillance
- Industrial inspection
- Machine vision
- Military and space applications