

Mako G

G-131



- Ultra-compact design
- Teledyne e2v Sapphire CMOS sensor
- Switchable shutter modes
- 62 fps at full resolution

Description

GigE Vision camera, Teledyne e2v Sapphire CMOS sensor, 62 fps

Mako G-131 is a 1.3 megapixel GigE machine camera that incorporates the high quality Type 1/11.8 (8.7 mm diagonal) Teledyne e2v Sapphire EV76C560 CMOS sensor. At full resolution, this camera runs 62 frames per second. With a smaller region of interest, higher frame rates are possible.

Mako G cameras have the same ultra-compact form factor and the same mounting positions as many analog cameras. All models include Power over Ethernet (PoE), three opto-isolated outputs, and a 64 MB image buffer. The image quality profits from the precisely aligned sensor. By default monochrome models ship with no optical filter and color models ship with IRC Hoya C-5000 IR cut filter.

Benefits and features:

- Monochrome (G-131B) and color (G-131C) models
- GigE Vision interface with Power over Ethernet
- Screw mount RJ45 Ethernet connector for secure operation in industrial environments
- Supports cable lengths up to 100 meters (CAT-5e or CAT-6)
- Comprehensive I/O functionality for simplified system integration
- Popular C-Mount lens mount
- Easy camera mounting via standard M3 threads on top and bottom of housing or optional tripod adapter
- Easy software integration with Allied Vision's [Vimba SDK](#) and compatibility to the most popular [third party image-processing libraries](#).
- Defect pixel masking feature with the Defect Mask Loader tool that allows you to manage a user defined defective pixel list to match your application and optimize the life cycle of the camera.



Options:

- Available with CS-Mount or M12-Mount adapter
- Available with Protection glass B 270 (ASG), IRC type Jenofilt 217 (IR cut filter), IRC Hoya C-5000 (IR cut filter), IRP RG715 (IR pass filter), IRP RG830 (IR pass filter)

See the [Modular Concept](#) for lens mount and optical filter options.

See the [Customization and OEM Solutions](#) webpage for additional options.

Specifications

Mako G	G-131
Interface	IEEE 802.3 1000BASE-T, IEEE 802.3af (PoE)
Resolution	1280 (H) × 1024 (V)
Sensor	Teledyne e2v EV76C560
Sensor type	CMOS
Sensor size	Type 1/1.8
Pixel size	5.3 μm × 5.3 μm
Lens mount (default)	C-Mount
Max. frame rate at full resolution	62 fps
ADC	10 bit
Image buffer (RAM)	64 MByte
Output	
Bit depth	8/10 bit
Monochrome pixel formats	Mono8, Mono10
YUV color pixel formats	YUV411Packed, YUV422Packed, YUV444Packed
RGB color pixel formats	RGB8Packed, BGR8Packed
Raw pixel formats	BayerBG8, BayerBG10
General purpose inputs/outputs (GPIOs)	
Opto-isolated I/Os	1 input, 3 outputs
Operating conditions/dimensions	
Operating temperature	+5 °C to +45 °C housing temperature
Power requirements (DC)	12 to 24 VDC AUX or 802.3at Type 1 PoE
Power consumption	2.0 W at 12 VDC; 2.2 W PoE
Mass	80 g
Body dimensions (L × W × H in mm)	60.5 × 29.2 × 29.2 (including connectors)
Regulations	CE: 2014/30/EU (EMC), 2011/65/EU, including amendment 2015/863/EU (RoHS); FCC Class B; CAN ICES-003

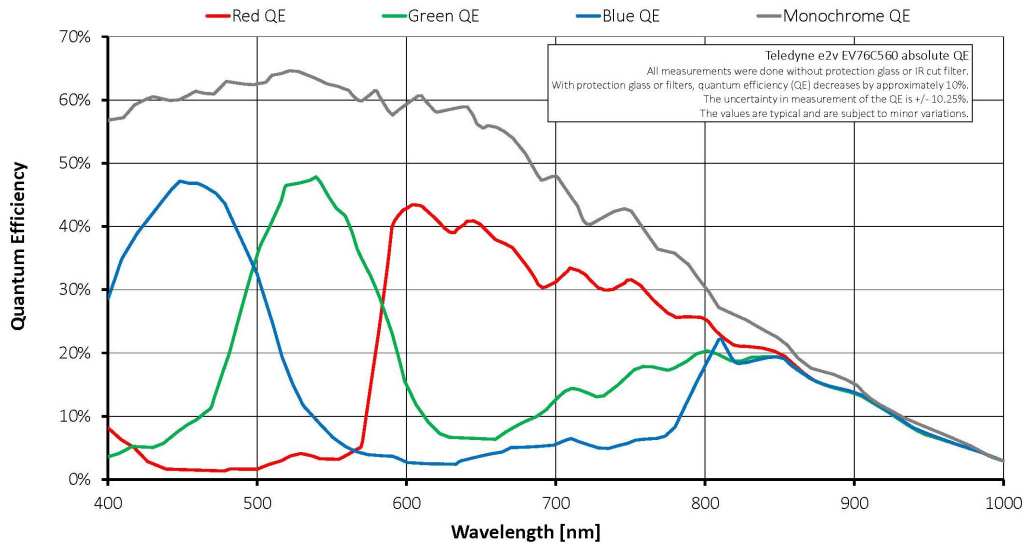

Features

Image optimization features:

- Auto gain (manual gain control: 0 to 24 dB, 1 dB increments)
- Auto exposure (exposure time control varies by pixel format)
- Auto white balance (G-131C only)
- Binning (1x1 and 2x2 binning)
- Color correction, hue, saturation (G-131C only)
- Decimation
- Defect pixel masking (user defined with Defect Mask Loader tool)
- Gamma correction
- One look-up table (LUT)
- Region of interest (ROI), separate ROI for auto features
- Reverse X/Y

Camera control features:

- Event channel
- Image chunk data
- Storable user sets
- StreamBytesPerSecond (bandwidth control)
- Stream hold
- Sync out modes: Trigger ready, input, exposing, readout, imaging, strobe, GPO
- Switchable Rolling, Global, GlobalReset shutter modes

- Temperature monitoring (main board only)

Technical drawing

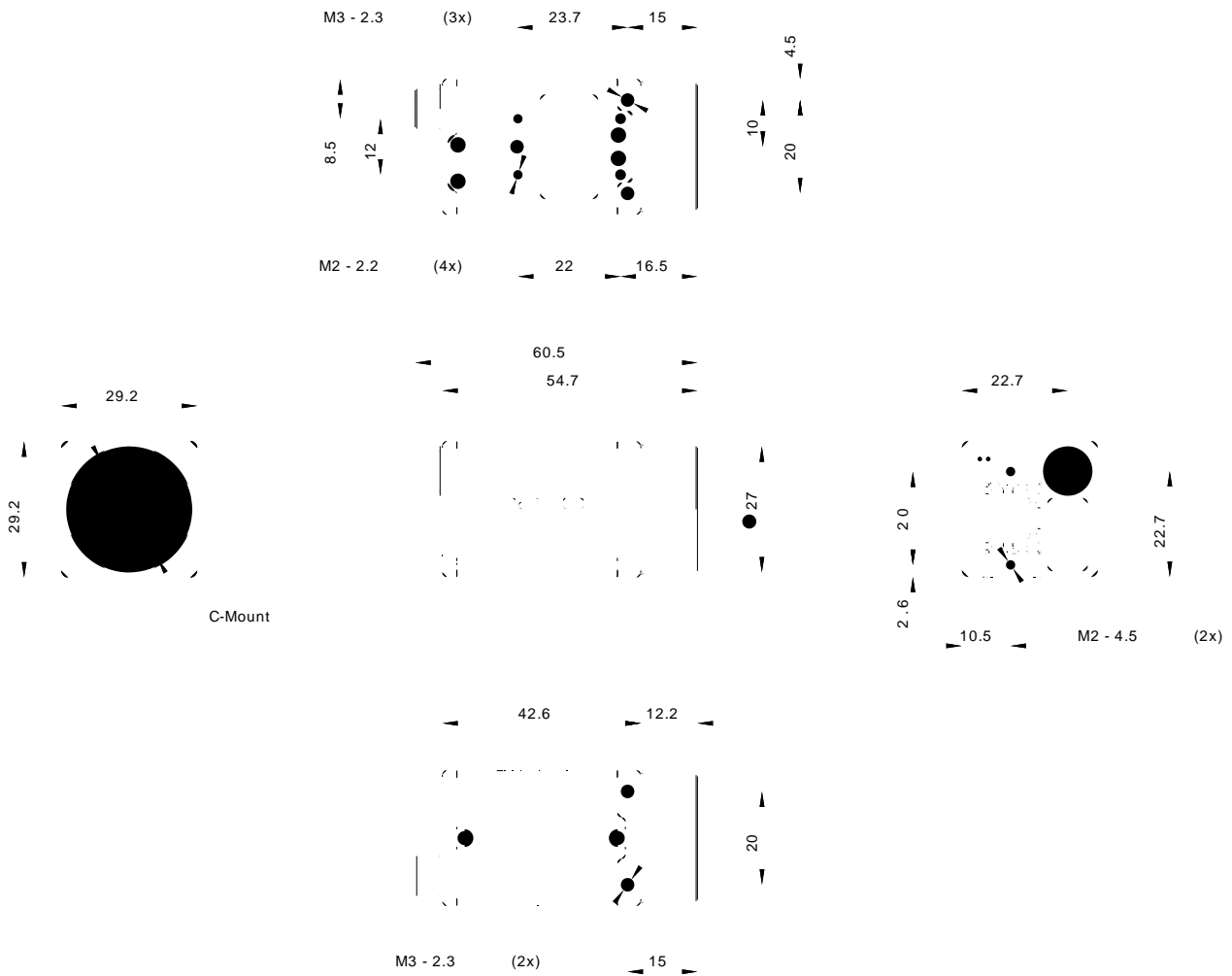



Applications

Mako G-131 is ideal for a wide range of applications including:

- Robotics
- Quality control
- Inspection, surveillance
- Industrial imaging
- Machine vision
- Logistics