

# SHR CoaXPress

shr661CCX12



## General

Model	shr661CCX12
Product code	F004142
Product series	SHR CoaXPress
Status	Available

## Sensor

Sensor type	Area scan
Chroma	Color
Spectrum	Visible
Spectral range	400 nm to 1000 nm
Resolution	13,392 × 9,528 (127.60 MP)
Sensor model	Sony IMX661
Sensor architecture (material)	cmos
Shutter type(s)	global-shutter
Sensor size	46.2 × 32.87 mm (56.7 mm, 56.73mm (Type 3.6))
Pixel size	3.45 μm × 3.45 μm

## Pixel formats

Sensor bit depth	8-Bit,10-Bit,12-Bit,16-Bit
RGB pixel formats	bayer8, bayer10, bayer12, bayer16

## Imaging performance

Dynamic range	74.4 dB
SNR	41.5 dB

## Timing and gain

Max. frame rate	20.3 fps
Exposure time	1 $\mu$ s to 60 s
Gain	0.0 dB to 36.0 dB

## I/Os and power

Non-isolated lines	0 x LVDS input, 0 x LVDS output, 0 x TTL input, 0 x TTL output, 2 x 24V input, 4 x Open drain output,
Specific non-isolated lines	1 x RS232 input, 1 x RS232 output, 0 x RS422 input, 0 x RS422 output,
Opto-isolated lines	1 x Optical isolated input, 0 x Optical isolated input,
Power supply	10 to 25VDC, Power over CoaXPress
Power consumption	External: 17 W (typical)

## Operating conditions

Operating temperature (housing)	-10 °C to 60 °C
---------------------------------	-----------------

## Mechanical properties

Body dimensions (L x W x H in mm)	83 x 80 x 80
Filter/protection glass	IR-Cut 680
IP class	IP30
Lens mount(s)	M72x0.75
Weight	580 g

## On-board memory and FPGA

Non-volatile memory (Flash)	160 MByte
-----------------------------	-----------

## Interfaces

Digital interface	cxp-12 with 4 connections
Interface connector	(micro-BNC)

## FW features - image control

Exposure modes	Manual, Auto, External
Gain modes	Auto, Manual
White balance modes	auto, manual
Image control features	FW Features - Image Control

## FW features - camera control

Trigger modes/sync INTERNAL,SOFTWARE,EXTERNAL

Camera control features PoCxP, User Sets, PWM(4), Sequencer,

Quantum Efficiency

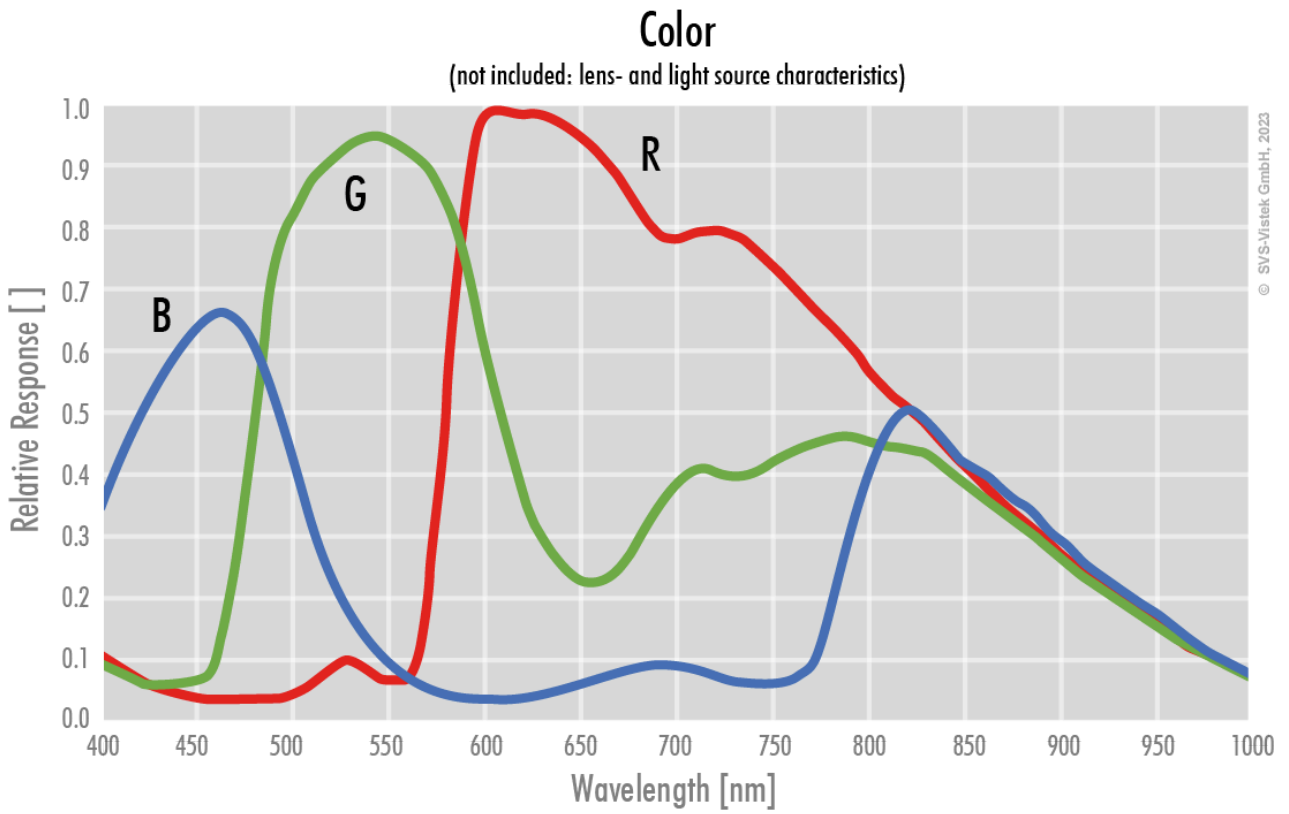

Technical Drawing

front

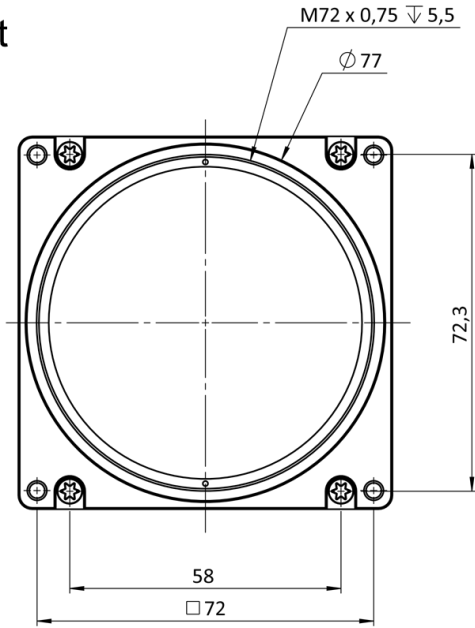

back

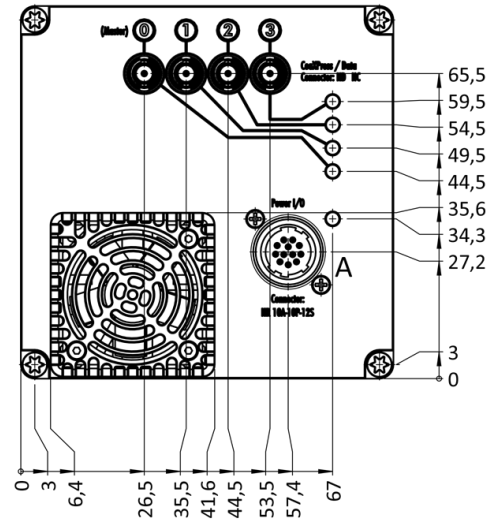

cross section

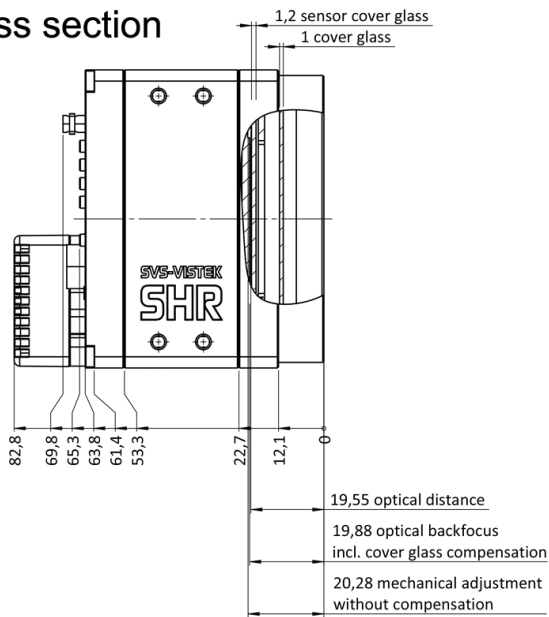

right side

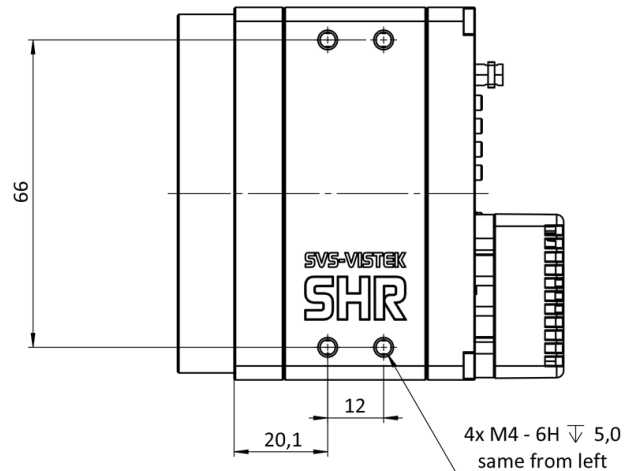

top

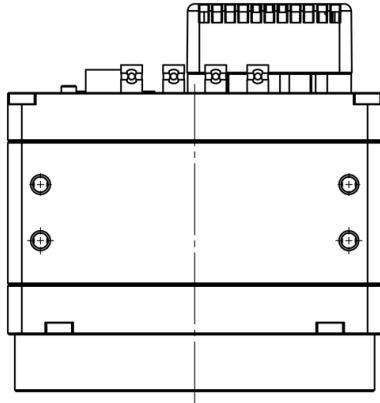

bottom

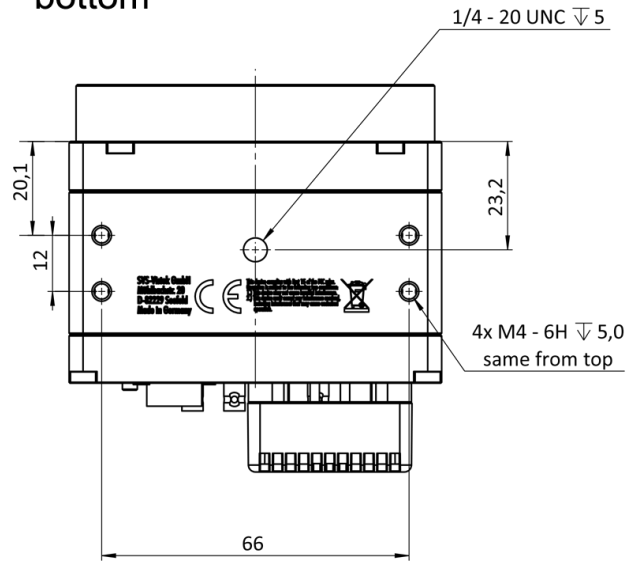

3D

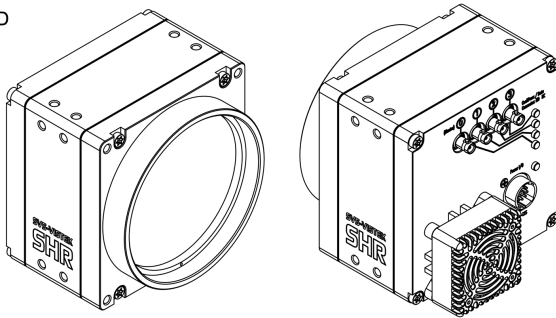

## I/O pin assignment



1	VIN - (GND)	7	OUT 1 (open drain)
2	VIN + (10 V to 25 V DC)	8	OUT 2 (open drain)
3	IN 4 (RXD RS232)	9	IN 3 + (opto In +)
4	OUT 4 (TXD RS232)	10	IN 3 - (opto In -)
5	IN 1 (0-24V)	11	OUT 3 (open drain)
6	IN 2 (0-24V)	12	OUT 0 (open drain)