

SHR CoaXPress

shr461MCX



General

Model	shr461MCX
Product code	F004086
Product series	SHR CoaXPress
Status	Available

Sensor

Sensor type	Area scan
Chroma	Mono
Spectrum	Visible
Spectral range	400 nm to 1000 nm
Resolution	11,648 × 8,742 (101.80 MP)
Sensor model	Sony IMX461
Sensor architecture (material)	cmos
Shutter type(s)	rolling-shutter
Sensor size	43.8 × 32.87 mm (54.76 mm, 55mm (Type 3.4))
Pixel size	3.76 μm × 3.76 μm

Pixel formats

Sensor bit depth	8-Bit,10-Bit,12-Bit,16-Bit
Monochrome pixel formats	mono8, mono10, mono12, mono16

Imaging performance

Dynamic range	81.3 dB
SNR	46.8 dB

Timing and gain

Max. frame rate	8.7 fps
Exposure time	60 μ s to 60 s
Gain	0.0 dB to 36.0 dB

I/Os and power

Non-isolated lines	0 x LVDS input, 0 x LVDS output, 0 x TTL input, 0 x TTL output, 2 x 24V input, 4 x Open drain output,
Specific non-isolated lines	1 x RS232 input, 1 x RS232 output, 0 x RS422 input, 0 x RS422 output,
Opto-isolated lines	1 x Optical isolated input, 0 x Optical isolated input,
Power supply	10 to 25VDC, Power over CoaXPress
Power consumption	External: 14 W (typical)

Operating conditions

Operating temperature (housing)	-10 °C to 70 °C
---------------------------------	-----------------

Mechanical properties

Body dimensions (L x W x H in mm)	83 x 80 x 80
Filter/protection glass	Borofloat B270i - AR coating
IP class	IP30
Lens mount(s)	M72x0.75
Weight	580 g

On-board memory and FPGA

Non-volatile memory (Flash)	160 MByte
-----------------------------	-----------

Interfaces

Digital interface	cxp-6 with 4 connections
Interface connector	(Din1.0/2.3)

FW features - image control

Exposure modes	Manual, Auto
Gain modes	Auto, Manual
Image control features	FW Features - Image Control

FW features - camera control

Trigger modes/sync INTERNAL,SOFTWARE,EXTERNAL

Camera control features PoCxP, User Sets, PWM(4), Sequencer,

Quantum Efficiency

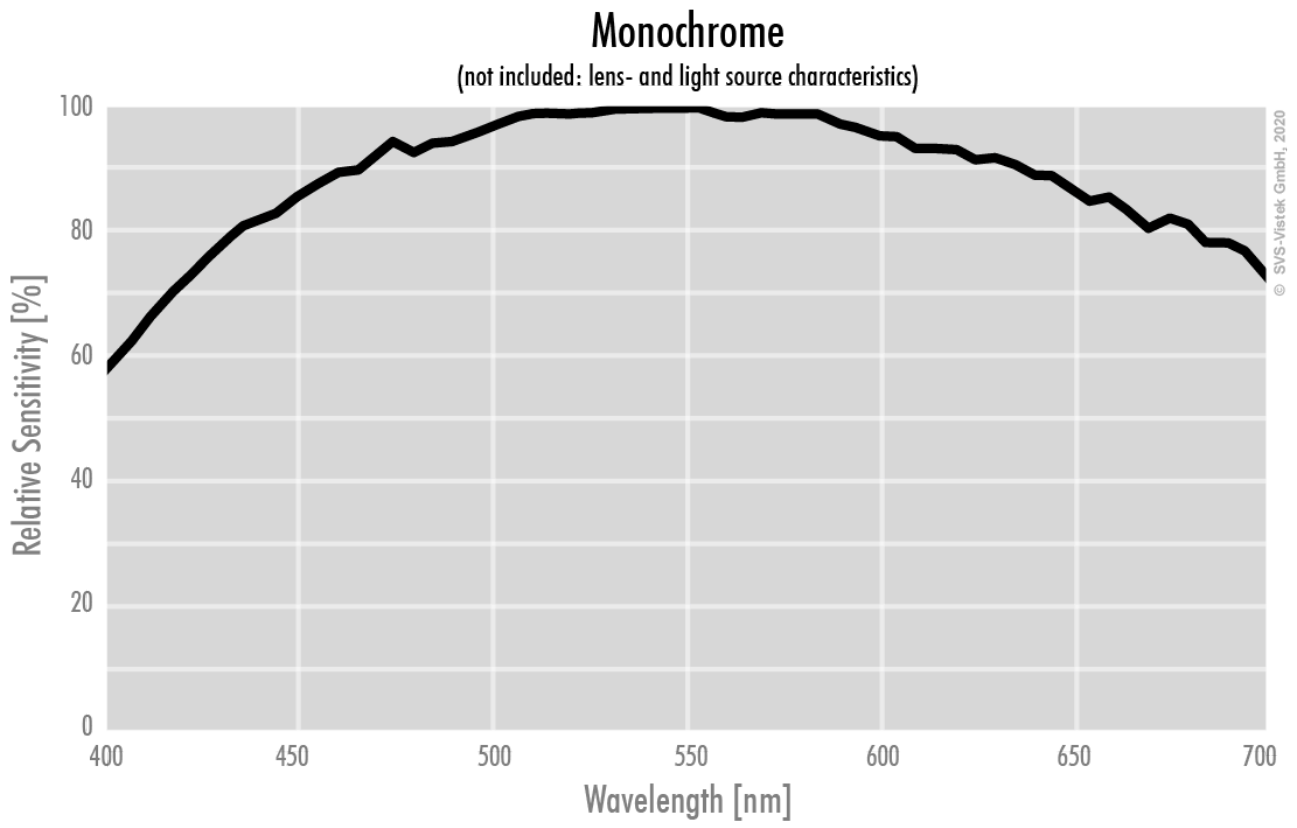

Technical Drawing

front

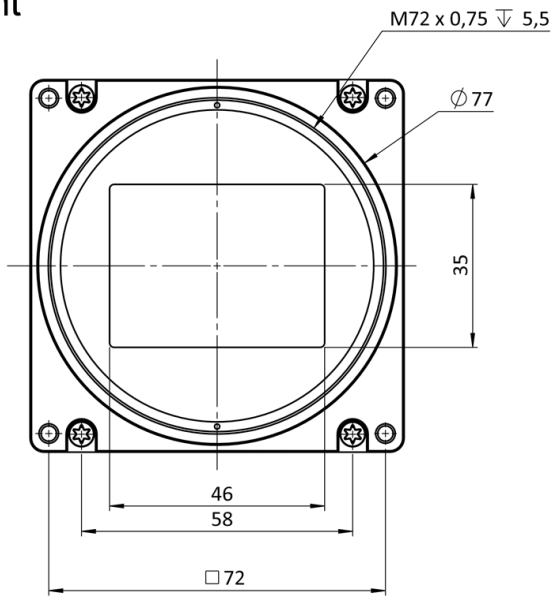

back

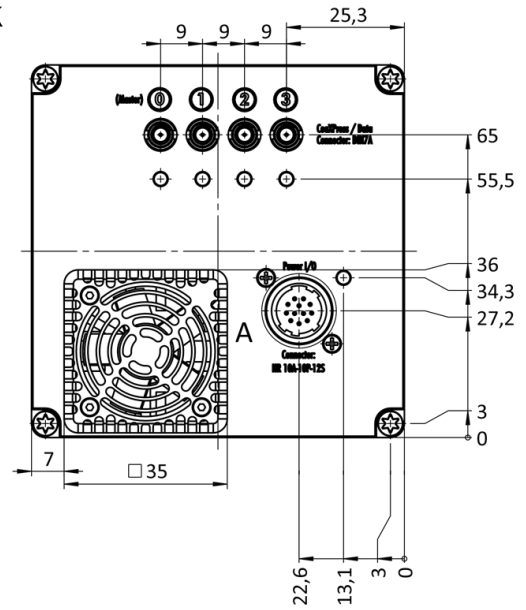

cross section

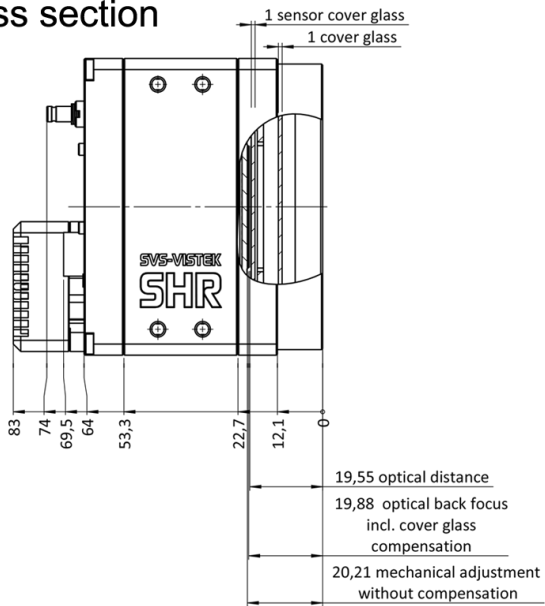

right side

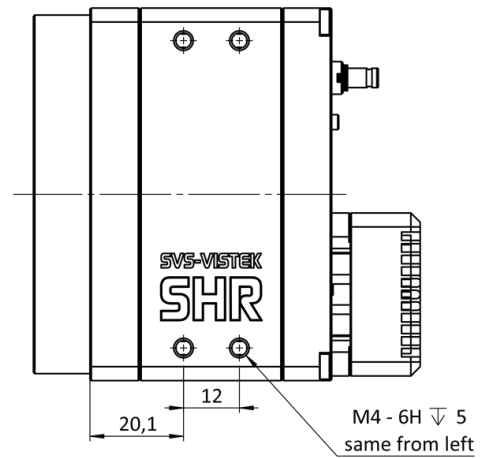

top

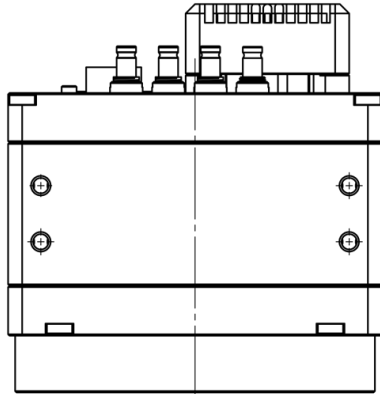

bottom

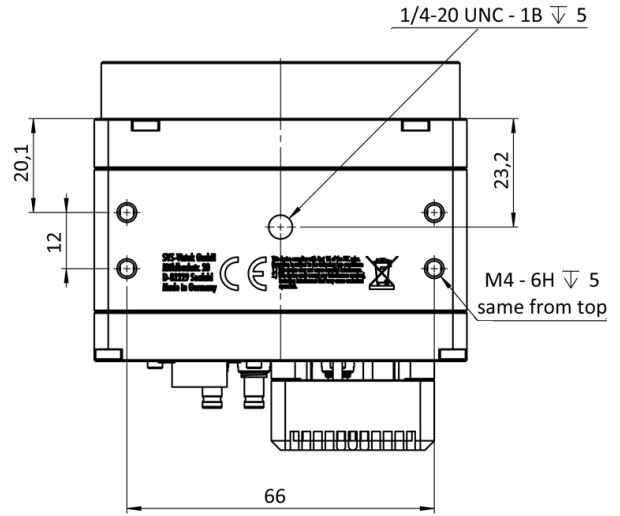

3D

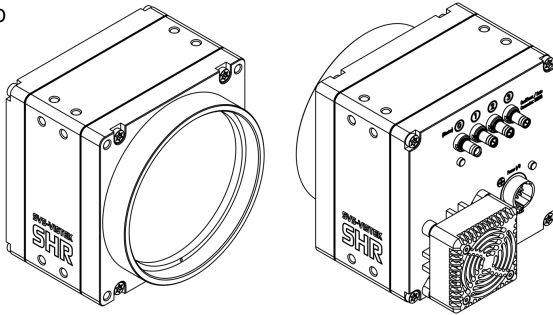

I/O pin assignment



1	VIN - (GND)	7	OUT 1 (open drain)
2	VIN + (10 V to 25 V DC)	8	OUT 2 (open drain)
3	IN 4 (RXD RS232)	9	IN 3 + (opto In +)
4	OUT 4 (TXD RS232)	10	IN 3 - (opto In -)
5	IN 1 (0-24V)	11	OUT 3 (open drain)
6	IN 2 (0-24V)	12	OUT 0 (open drain)