

SHR 10GigE

shr661CXGE



General

Model:	shr661CXGE
Product code:	F004144
Product series:	SHR 10GigE
Status:	Available

Sensor

Sensor type:	Area scan
Chroma:	Color
Spectrum:	Visible
Spectral range:	400 nm to 1000 nm
Resolution:	13,392 × 9,528 (127.60 MP)
Sensor model:	Sony IMX661LQA
Sensor architecture (material):	cmos
Shutter type(s):	global-shutter
Sensor size:	46.2 × 32.87 mm (56.7 mm, 56.73mm (Type 3.6))
Pixel size:	3.45 μm × 3.45 μm

Pixel formats

Sensor bit depth:	8-Bit, 12-Bit, 12-Bit
RGB pixel formats:	bayer8, bayer12packed

Imaging performance

Dynamic range: 74.4 dB

SNR: 41.5 dB

Timing and gain

Max. frame rate: 8.2

Exposure time: 163 μ s to 60 s

Gain: 0.0 dB to 36.0 dB

I/Os and power

Non-isolated lines: 0 x LVDS input, 0 x LVDS output, 0 x TTL input, 0 x TTL output, 2 x 24V input, 4 x Open drain output,

Specific non-isolated lines: 1 x RS232 input, 1 x RS232 output, 0 x RS422 input, 0 x RS422 output,

Opto-isolated lines: 1 x Optical isolated input, 0 x Optical isolated input,

Power supply: 10 to 25VDC, Power over Ethernet (POE+, in option -P)

Power consumption: External: 18 W (typical)

Operating conditions

Operating temperature (housing): -10 °C to 60 °C

Mechanical properties

Body dimensions (L x W x H in mm): 83 x 80 x 80

Filter/protection glass: IR-Cut 680

IP class: IP30

Lens mount(s): M72x0.75

Weight: 580 g

On-board memory and FPGA

Non-volatile memory (Flash): 32 MByte

Interfaces

Digital interface: 10gige

Interface connector: (RJ-45)

FW features - image control

Exposure modes: Manual, Auto, External

Gain modes: Auto, Manual

White balance modes: auto, manual

FW features - image control

Image control features:

FW Features - Image Control

FW features - camera control

Trigger modes/sync:

INTERNAL,SOFTWARE,EXTERNAL

Camera control features:

User Sets, POE, PWM(4), Sequencer,

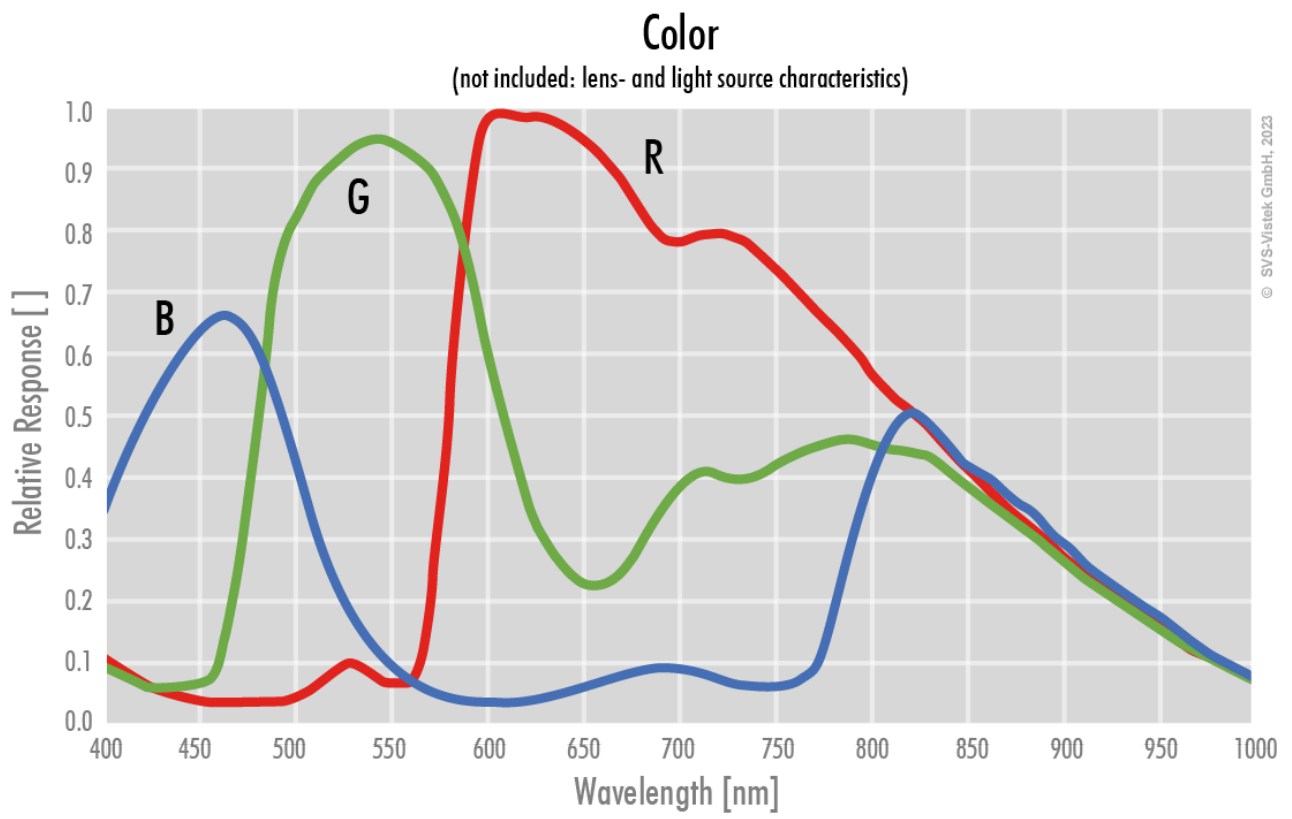

front

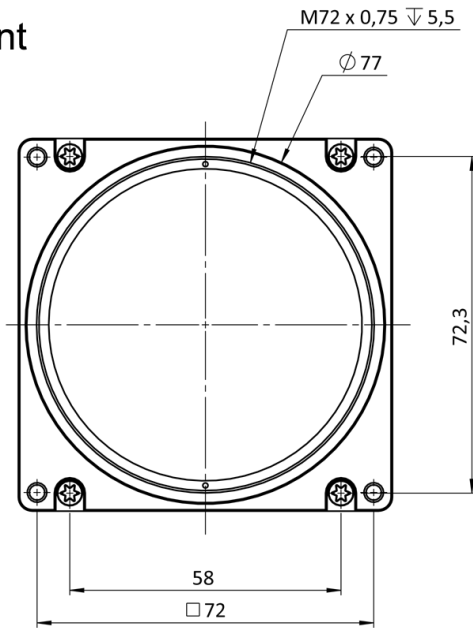

back

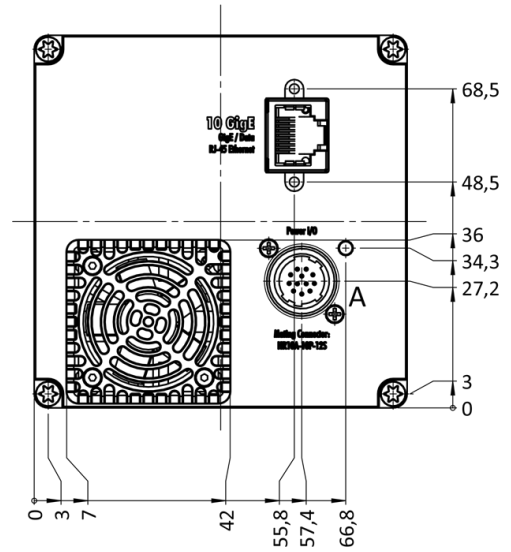

cross section

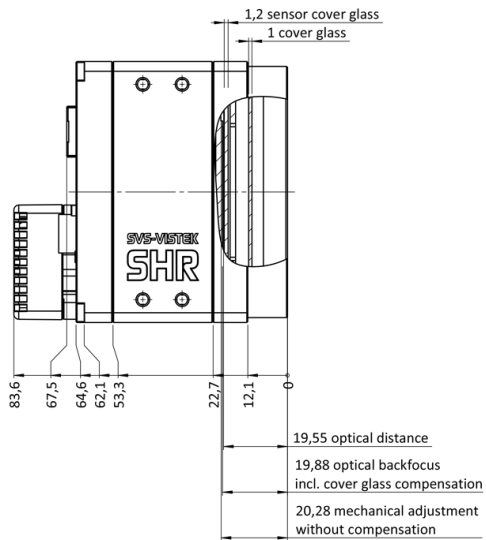

right side

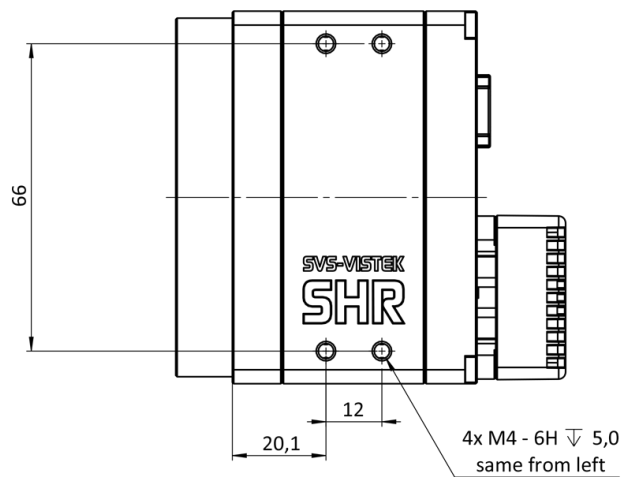

top

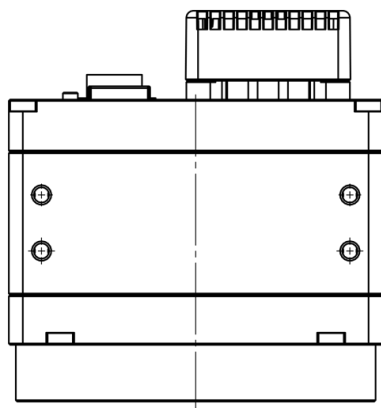

bottom

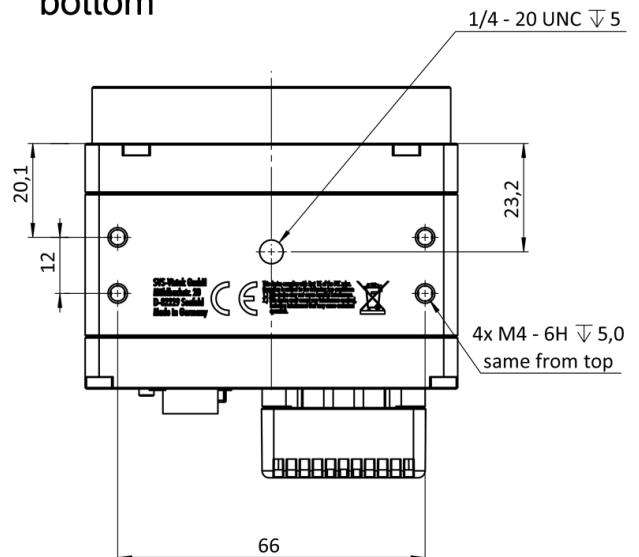

3D

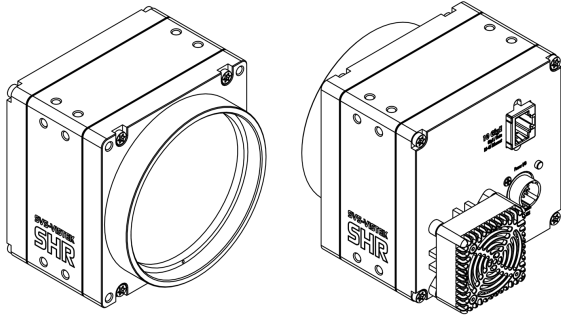

I/O pin assignment

Hirose 12 Pin



1	VIN -	(GND)	7	OUT 1	(open drain)
2	VIN +	(10 V to 25 V DC)	8	OUT 2	(open drain)
3	IN 4	(RXD RS232)	9	IN 3 +	(opto In +)
4	OUT 4	(TXD RS232)	10	IN 3 -	(opto In -)
5	IN 1	(0-24V)	11	OUT 3	(open drain)
6	IN 2	(0-24V)	12	OUT 0	(open drain)