

SHR CoaXPress

shr411CCX



General

Model:	shr411CCX
Product code:	F004074
Product series:	SHR CoaXPress
Status:	Available

Sensor

Sensor type:	Area scan
Chroma:	Color
Spectrum:	Visible
Spectral range:	400 nm to 1000 nm
Resolution:	14,192 × 10,640 (151.00 MP)
Sensor model:	Sony IMX411AQR
Sensor architecture (material):	cmos
Shutter type(s):	rolling-shutter
Sensor size:	53.36 × 40.01 mm (66.69 mm, 66.7mm (Type 4.2))
Pixel size:	3.76 μm × 3.76 μm

Pixel formats

Sensor bit depth:	8-Bit,10-Bit,12-Bit,16-Bit
RGB pixel formats:	bayer8, bayer10, bayer12, bayer16

Imaging performance

Dynamic range:	78 dB
SNR:	46.9 dB

Timing and gain

Max. frame rate:	6.2
Exposure time:	60 µs to 60 s
Gain:	0.0 dB to 36.0 dB

I/Os and power

Non-isolated lines:	0 x LVDS input, 0 x LVDS output, 0 x TTL input, 0 x TTL output, 2 x 24V input, 4 x Open drain output,
Specific non-isolated lines:	1 x RS232 input, 1 x RS232 output, 0 x RS422 input, 0 x RS422 output,
Opto-isolated lines:	1 x Optical isolated input, 0 x Optical isolated input,
Power supply:	10 to 25VDC, Power over CoaXPress
Power consumption:	External: 14 W (typical)

Operating conditions

Operating temperature (housing):	-10 °C to 65 °C
----------------------------------	-----------------

Mechanical properties

Body dimensions (L x W x H in mm):	83 × 80 × 80
Filter/protection glass:	IR-Cut - 680nm
IP class:	IP30
Lens mount(s):	M72x0.75
Weight:	600 g

On-board memory and FPGA

Non-volatile memory (Flash):	160 MByte
------------------------------	-----------

Interfaces

Digital interface:	cxp-6 with 4 connections
Interface connector:	(Din1.0/2.3)

FW features - image control

Exposure modes:	Manual, Auto
Gain modes:	Auto, Manual
White balance modes:	auto, manual

FW features - image control

Image control features:

FW Features - Image Control

FW features - camera control

Trigger modes/sync:

INTERNAL,SOFTWARE,EXTERNAL

Camera control features:

PoCxP, User Sets, PWM(4), Sequencer,

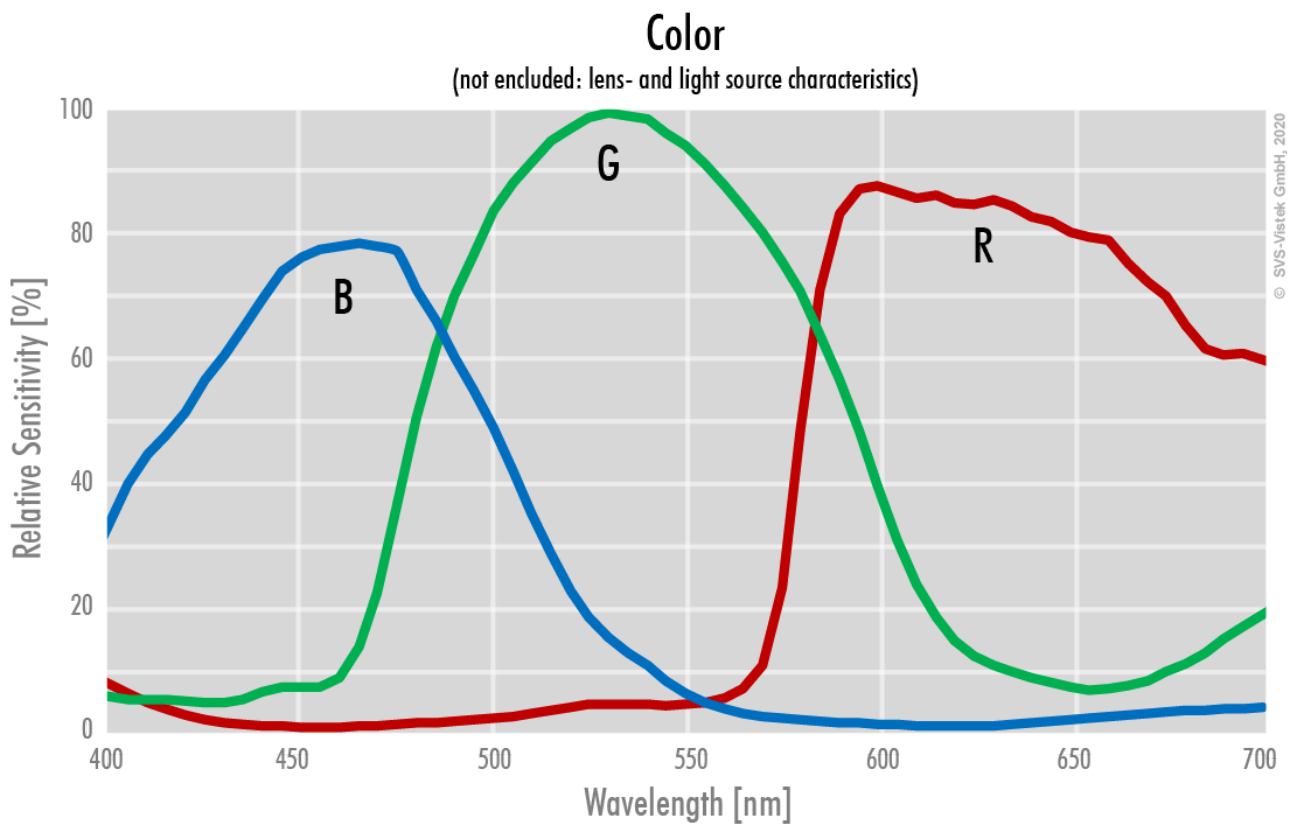

front view

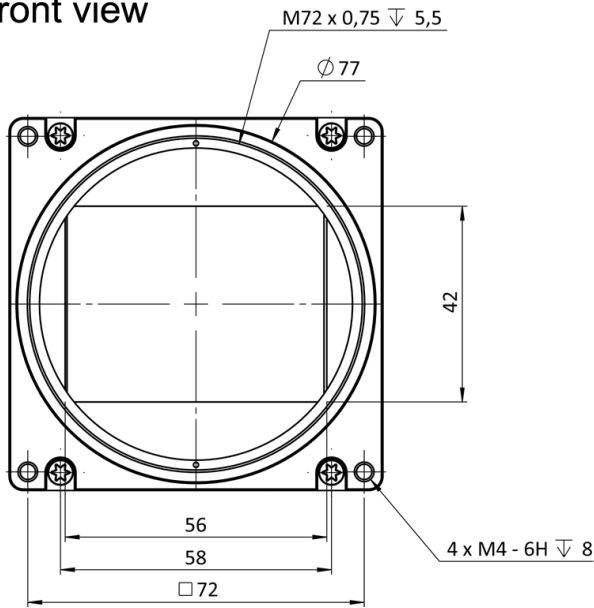

back view

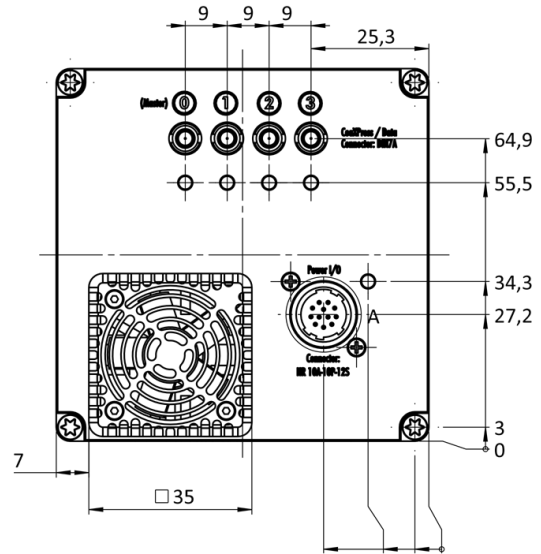

cross section

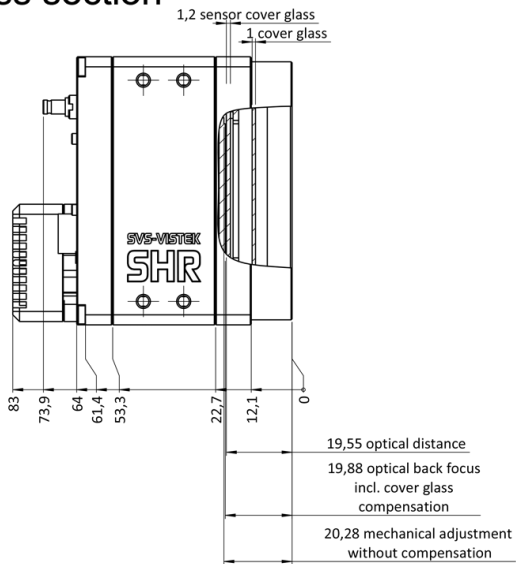

right view

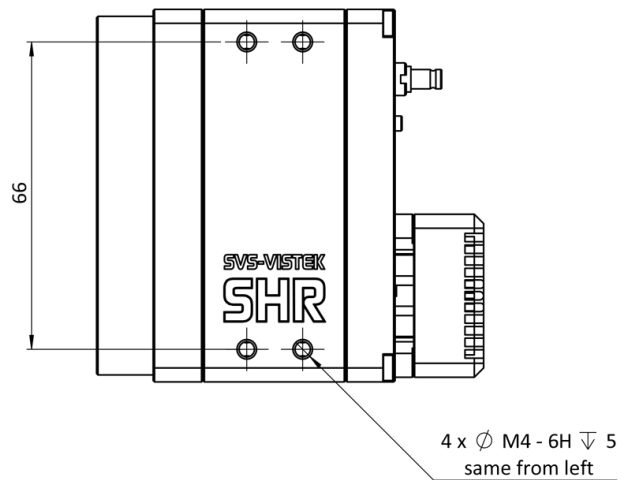

top view

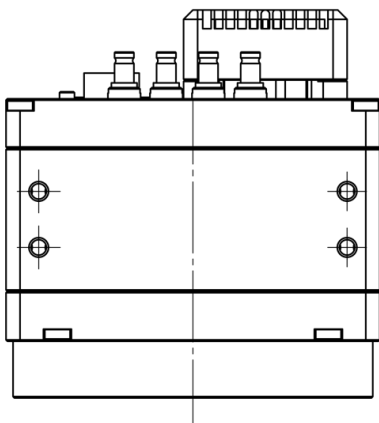

bottom view

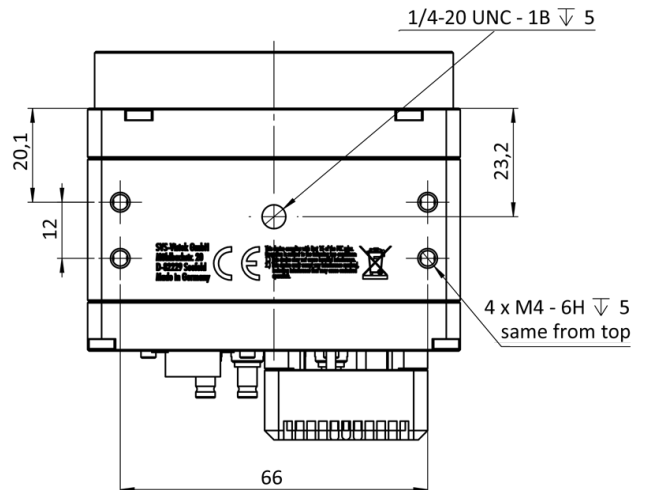

3D view

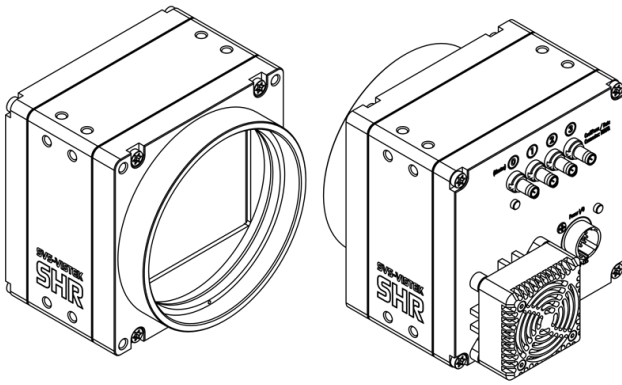

I/O pin assignment



Hirose 12 Pin

1	VIN - (GND)	7	OUT 1 (open drain)
2	VIN + (10 V to 25 V DC)	8	OUT 2 (open drain)
3	IN 4 (RXD RS232)	9	IN 3 + (opto In +)
4	OUT 4 (TXD RS232)	10	IN 3 - (opto In -)
5	IN 1 (0-24V)	11	OUT 3 (open drain)
6	IN 2 (0-24V)	12	OUT 0 (open drain)