



General

Model:	hr49MCX12
Product code:	F004183
Product series:	HR CoaXPress
Status:	Available

Sensor

Sensor type:	Area scan
Chroma:	Mono
Spectrum:	Visible
Spectral range:	400 nm to 1000 nm
Resolution:	7,008 × 7,000 (49.00 MP)
Sensor model:	Gpixel GMAX3265-49
Sensor architecture (material):	cmos
Shutter type(s):	global-shutter
Sensor size:	22.43 × 22.4 mm (31.7 mm, 37.4mm (2.3"))
Pixel size:	3.20 μm × 3.20 μm

Pixel formats

Sensor bit depth:	8-Bit,10-Bit
Monochrome pixel formats:	mono8, mono10

Timing and gain

Max. frame rate:	71
Exposure time:	12 μ s to 60 s
Gain:	0.0 dB to 18.0 dB

I/Os and power

Non-isolated lines:	0 x LVDS input, 0 x LVDS output, 0 x TTL input, 0 x TTL output, 2 x 24V input, 4 x Open drain output,
Specific non-isolated lines:	1 x RS232 input, 1 x RS232 output, 0 x RS422 input, 0 x RS422 output,
Opto-isolated lines:	1 x Optical isolated input, 0 x Optical isolated input,
Power supply:	10 to 25VDC
Power consumption:	External: 18 W (typical)

Operating conditions

Operating temperature (housing):	-10 °C to 60 °C
----------------------------------	-----------------

Mechanical properties

Body dimensions (L x W x H in mm):	76 × 70 × 70
IP class:	IP30
Lens mount(s):	M58x0.75
Weight:	420 g

On-board memory and FPGA

Non-volatile memory (Flash):	32 MByte
------------------------------	----------

Interfaces

Digital interface:	cxp-12 with 4 connections
Interface connector:	(micro-BNC)

FW features - image control

Exposure modes:	Manual, Auto, External
Gain modes:	Auto, Manual
Image control features:	FW Features - Image Control

FW features - camera control

Trigger modes/sync:	INTERNAL,SOFTWARE,EXTERNAL
Camera control features:	User Sets, PWM(4), Sequencer,

Monochrome

(not included: lens- and light source characteristics)

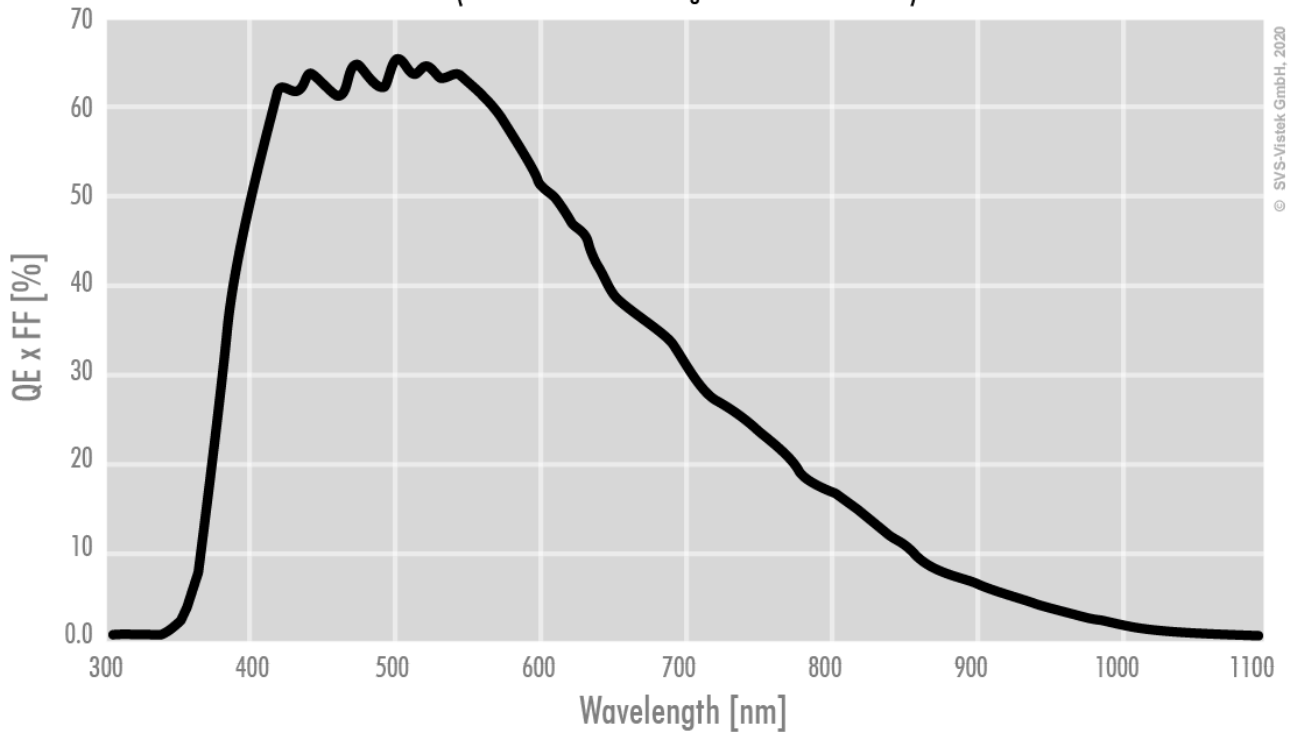

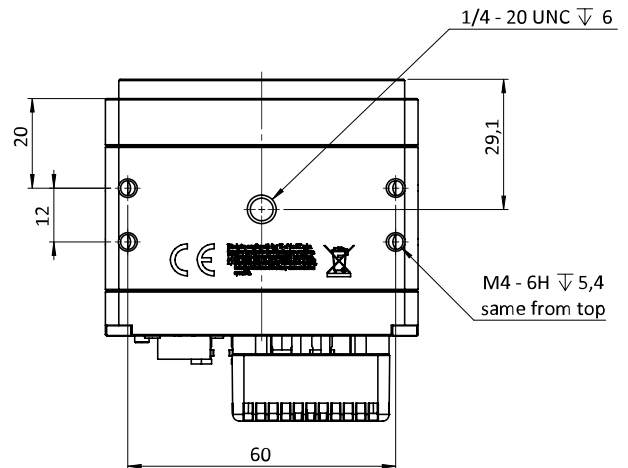
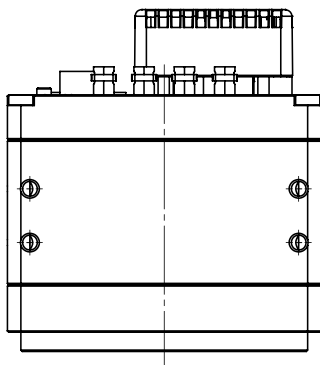
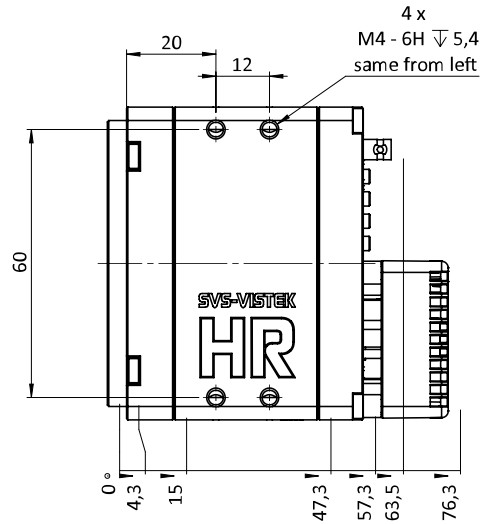
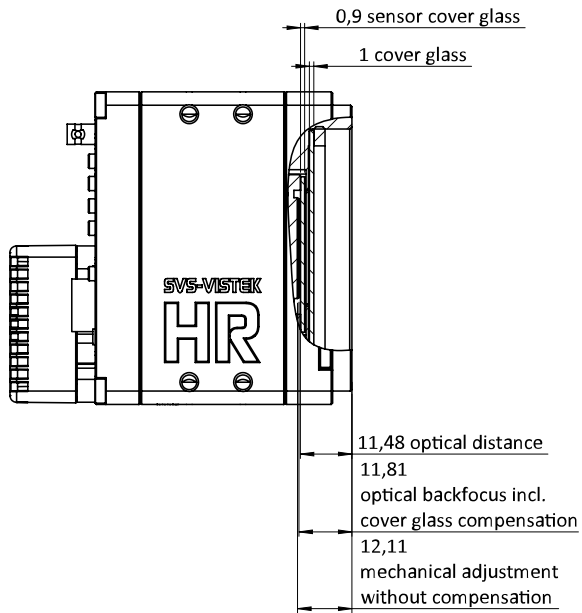
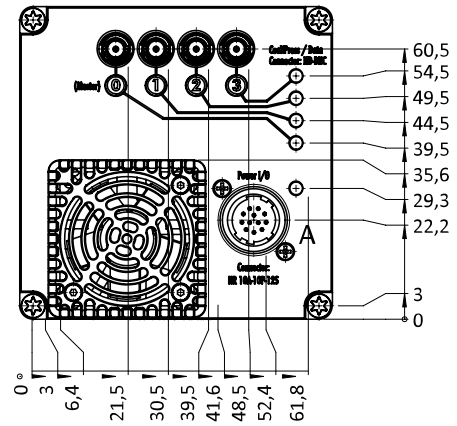
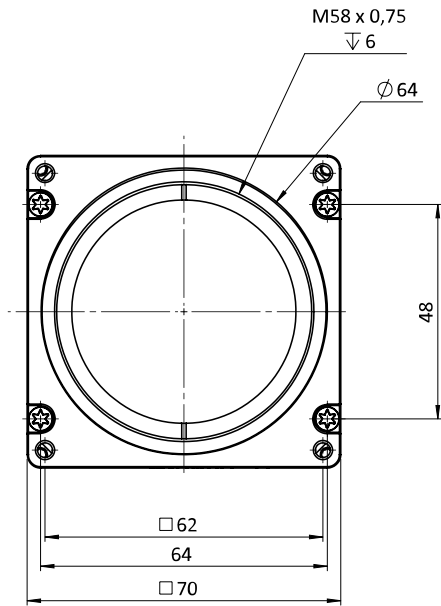

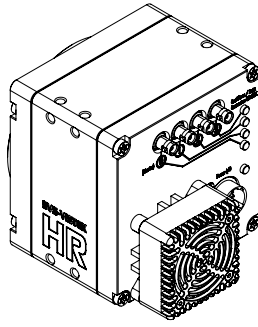
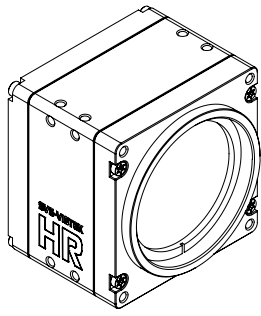

I/O pin assignment

Hirose 12 Pin



1	VIN-	(GND)	7	OUT1	(open drain)
2	VIN+	(10V to 25V DC)	8	OUT2	(open drain)
3	IN4	(RXD RS232)	9	IN3+	(opto In+)
4	OUT4	(TXD RS232)	10	IN3-	(opto In-)
5	IN1	(0-24V)	11	OUT3	(open drain)
6	IN2	(0-24V)	12	OUT0	(open drain)