

HR CoaXPress

hr65CCX-12



Preliminary product information. Features and technical specifications are subject to change without notice.

General

Model:	hr65CCX-12
Product code:	F004161
Product series:	HR CoaXPress
Status:	Coming soon

Sensor

Sensor type:	Area scan
Chroma:	Color
Spectrum:	Visible
Spectral range:	400 nm to 1000 nm
Resolution:	9,344 × 7,000 (65.00 MP)
Sensor model:	Gpixel GMAX3265
Sensor architecture (material):	cmos
Shutter type(s):	global-shutter
Sensor size:	29.9 × 22.4 mm (37.36 mm, 37.4mm)
Pixel size:	3.20 μm × 3.20 μm

Pixel formats

Sensor bit depth:	8-Bit,12-Bit
RGB pixel formats:	bayer8, bayer12

Imaging performance

Dynamic range: 65.6 dB

SNR: 40 dB

Timing and gain

Max. frame rate: 31.5

Exposure time: 14 μ s to 60 s

Gain: 0.0 dB to 18.0 dB

I/Os and power

Non-isolated lines: 0 x LVDS input, 0 x LVDS output, 0 x TTL input, 0 x TTL output, 2 x 24V input, 4 x Open drain output,

Specific non-isolated lines: 1 x RS232 input, 1 x RS232 output, 0 x RS422 input, 0 x RS422 output,

Opto-isolated lines: 1 x Optical isolated input, 0 x Optical isolated input,

Power supply: 10 to 25VDC, Power over CoaXPress

Power consumption: External: 10.5 W (typical)

Operating conditions

Operating temperature (housing): -10 °C to 65 °C

Mechanical properties

Body dimensions (L x W x H in mm): 76 x 70 x 70

Filter/protection glass: IR-Cut 680

IP class: IP30

Lens mount(s): M58x0.75

Weight: 420 g

On-board memory and FPGA

Non-volatile memory (Flash): 160 MByte

Interfaces

Digital interface: cxp-6 with 4 connections

Interface connector: (Din1.0/2.3)

FW features - image control

Exposure modes: Manual, Auto

Gain modes: Auto, Manual

White balance modes: auto, manual

FW features - image control

Image control features:

FW Features - Image Control

FW features - camera control

Trigger modes/sync:

INTERNAL,SOFTWARE,EXTERNAL

Camera control features:

PoCxP, User Sets, PWM(4), Sequencer,

preliminary

Color

(not included: lens- and light source characteristics)

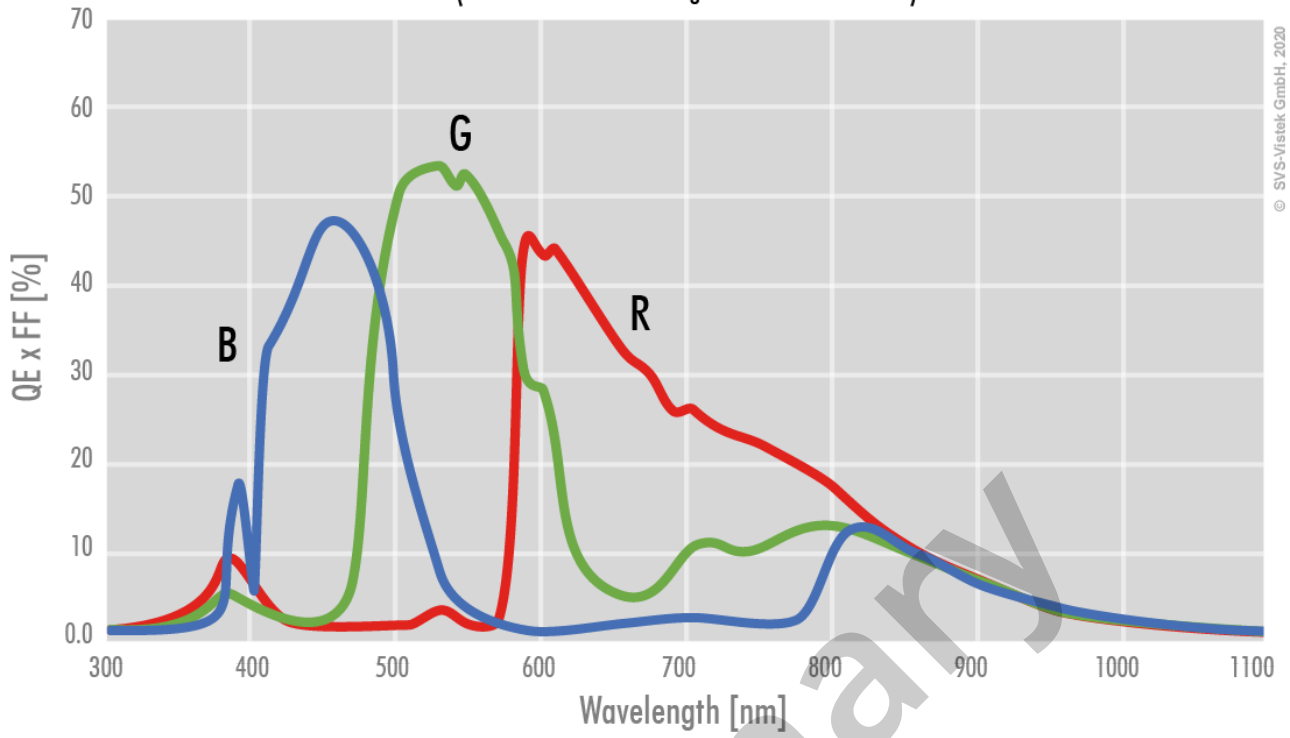

© SYS-Vistek GmbH, 2020

preliminary

front

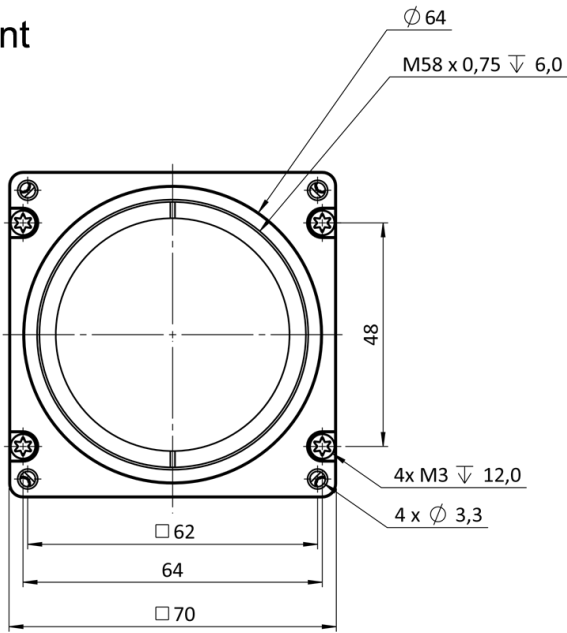

back

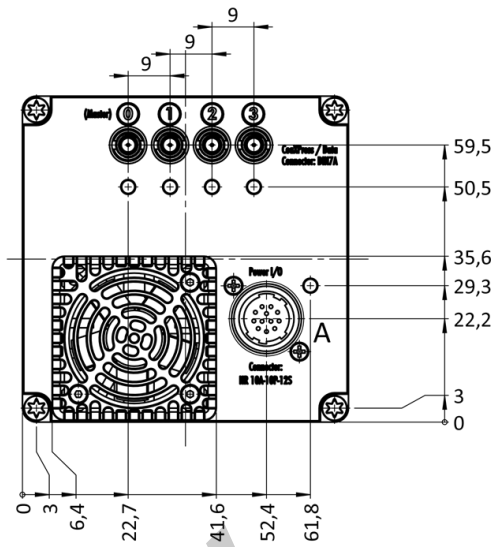

cross section

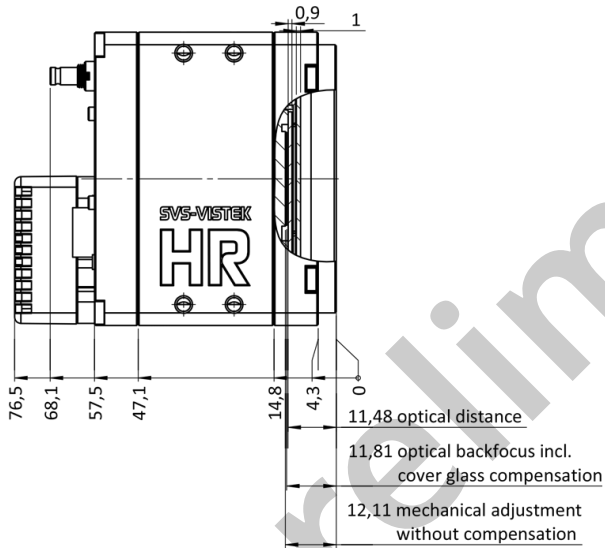

right side

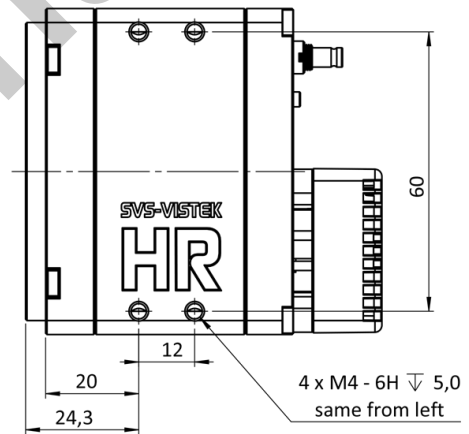

top

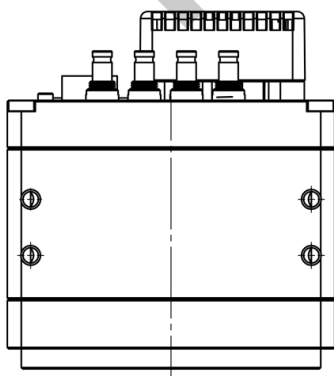

bottom

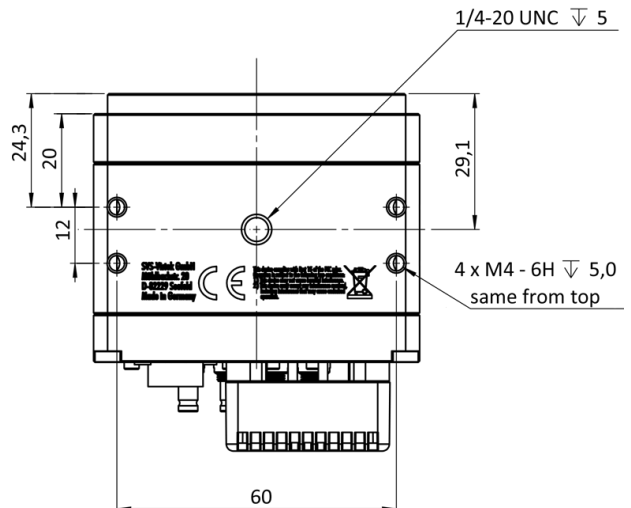

3D

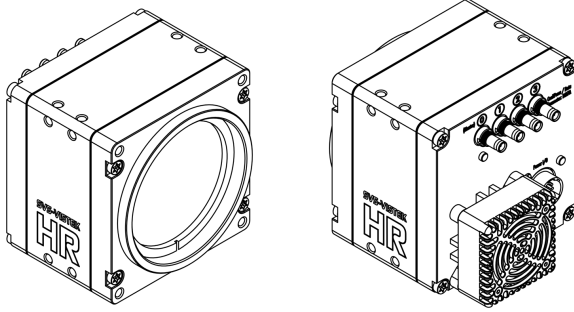

I/O pin assignment

Hirose 12 Pin



1	VIN -	(GND)	7	OUT 1	(open drain)
2	VIN +	(10 V to 25 V DC)	8	OUT 2	(open drain)
3	IN 4	(RXD RS232)	9	IN 3 +	(opto In +)
4	OUT 4	(TXD RS232)	10	IN 3 -	(opto In -)
5	IN 1	(0-24V)	11	OUT 3	(open drain)
6	IN 2	(0-24V)	12	OUT 0	(open drain)

preliminary