



HR 10GigE

hr65MXGE

General

Model	hr65MXGE
Product code	F004121
Product series	HR 10GigE
Status	Available

Sensor

Sensor type	Area scan
Chroma	Mono
Spectrum	Visible
Spectral range	400 nm to 1000 nm
Resolution	9,344 × 7,000 (65.00 MP)
Sensor model	Gpixel GMAX3265
Sensor architecture (material)	cmos
Shutter type(s)	global-shutter
Sensor size	29.9 × 22.4 mm (37.36 mm, 37.4mm)
Pixel size	3.20 μm × 3.20 μm

Pixel formats

Sensor bit depth	8-Bit,12-Bit
Monochrome pixel formats	mono8, mono12

Imaging performance

Dynamic range	65.6 dB
SNR	40 dB

Timing and gain

Max. frame rate	17.4 fps
Exposure time	62 μ s to 60 s
Gain	0.0 dB to 18.0 dB

I/Os and power

Non-isolated lines	0 x LVDS input, 0 x LVDS output, 0 x TTL input, 0 x TTL output, 2 x 24V input, 4 x Open drain output,
Specific non-isolated lines	1 x RS232 input, 1 x RS232 output, 0 x RS422 input, 0 x RS422 output,
Opto-isolated lines	1 x Optical isolated input, 0 x Optical isolated input,
Power supply	10 to 25VDC, Power over Ethernet (POE+, in option -P)
Power consumption	External: 14 W (typical)

Mechanical properties

Body dimensions (L x W x H in mm)	76 x 70 x 70
Filter/protection glass	N-BK7 - AR coating
IP class	IP30
Lens mount(s)	M58x0.75
Weight	420 g

On-board memory and FPGA

Image buffer (RAM)	448 MByte
Non-volatile memory (Flash)	32 MByte

Interfaces

Digital interface	10gige
Interface connector	(RJ-45)

FW features - image control

Exposure modes	Manual, Auto, External
Gain modes	Auto, Manual
Image control features	FW Features - Image Control

FW features - camera control

Trigger modes/sync	INTERNAL,SOFTWARE,EXTERNAL
--------------------	----------------------------

FW features - camera control

Camera control features

User Sets, POE, PWM(4), Sequencer,

Quantum Efficiency

Monochrome

(not included: lens- and light source characteristics)

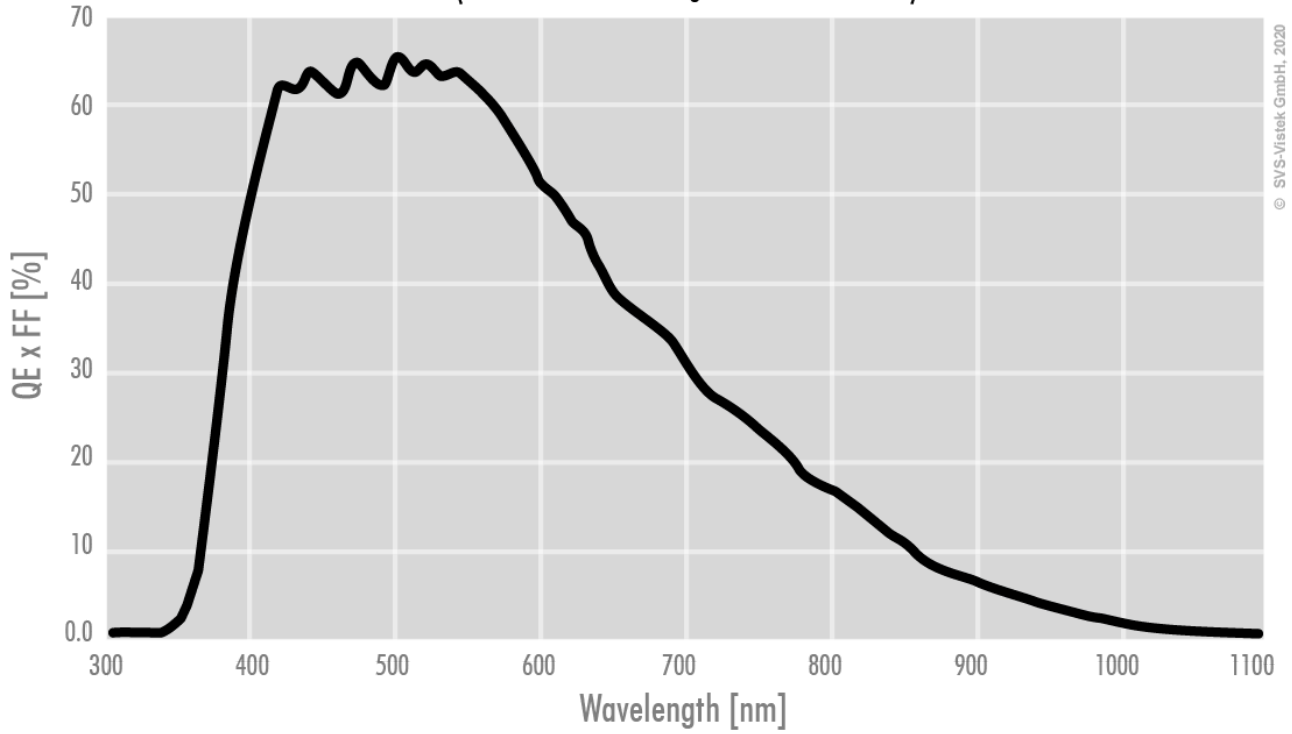

© SVS-Vistek GmbH, 2020

Technical Drawing

front

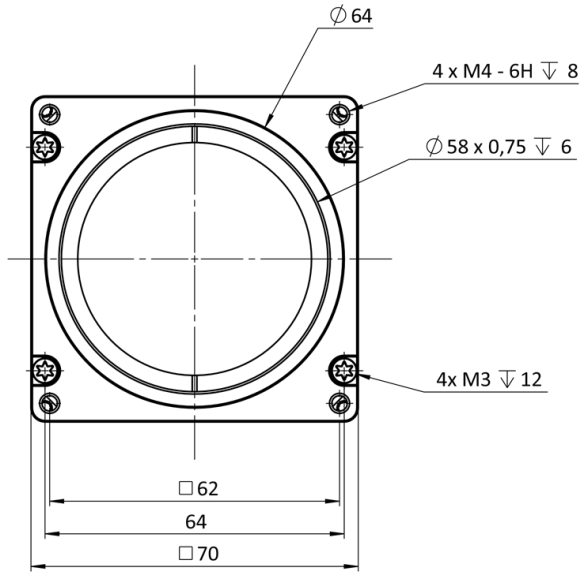

back

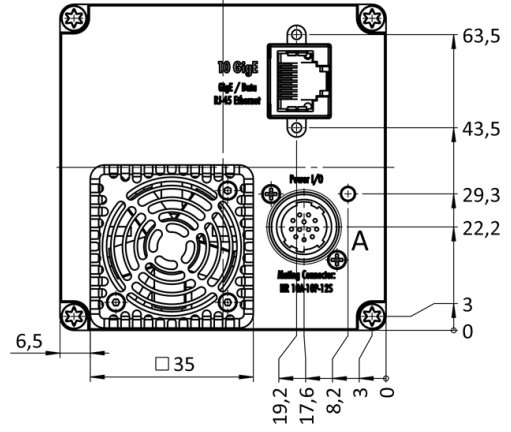

cross section

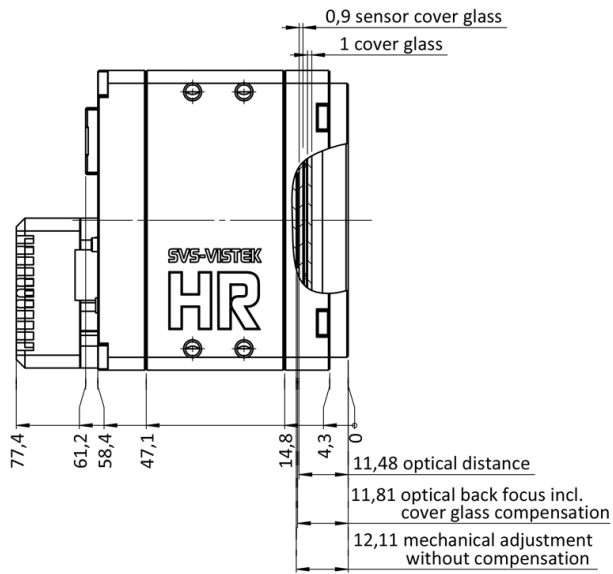

right side

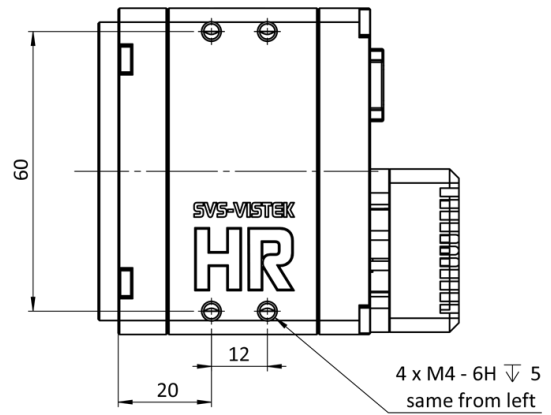

top

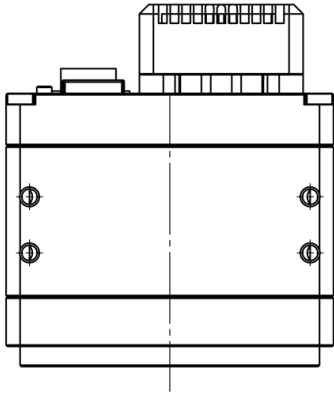

bottom

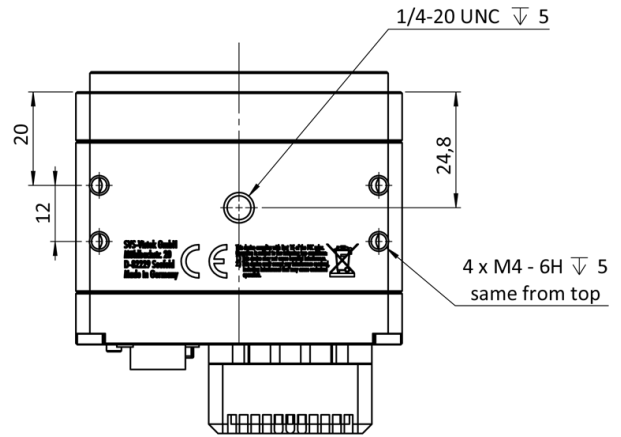

3D

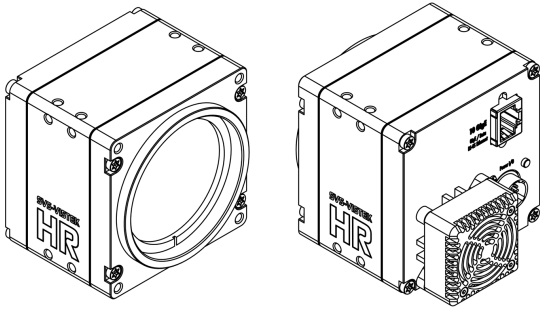

I/O pin assignment



1	VIN - (GND)	7	OUT 1 (open drain)
2	VIN + (10V to 25V DC)	8	OUT 2 (open drain)
3	IN 4 (RXD RS232)	9	IN 3 + (opto In +)
4	OUT 4 (TXD RS232)	10	IN 3 - (opto In -)
5	IN 1 (0-24V)	11	OUT 3 (open drain)
6	IN 2 (0-24V)	12	OUT 0 (open drain)