

# HR 10GigE

hr51CXGE



## General

Model	hr51CXGE
Product code	F004101
Product series	HR 10GigE
Status	Available

## Sensor

Sensor type	Area scan
Chroma	Color
Spectrum	Visible
Spectral range	400 nm to 1000 nm
Resolution	8,424 × 6,032 (51.00 MP)
Sensor model	Gpixel GMAX4651
Sensor architecture (material)	cmos
Shutter type(s)	global-shutter
Sensor size	38.75 × 27.75 mm (47.66 mm, 35mm Full Frame)
Pixel size	4.60 μm × 4.60 μm

## Pixel formats

Sensor bit depth	8-Bit,12-Bit
RGB pixel formats	bayer8, bayer12

## Imaging performance

Dynamic range	65 dB
SNR	42.6 dB

## Timing and gain

Max. frame rate	23.7 fps
Exposure time	17 $\mu$ s to 60 s
Gain	0.0 dB to 40.0 dB

## I/Os and power

Non-isolated lines	0 x LVDS input, 0 x LVDS output, 0 x TTL input, 0 x TTL output, 2 x 24V input, 4 x Open drain output,
Specific non-isolated lines	1 x RS232 input, 1 x RS232 output, 0 x RS422 input, 0 x RS422 output,
Opto-isolated lines	1 x Optical isolated input, 0 x Optical isolated input,
Power supply	10 to 25VDC, Power over Ethernet (POE+, in option -P)
Power consumption	External: 17 W (typical)

## Mechanical properties

Body dimensions (L x W x H in mm)	77 x 70 x 70
Filter/protection glass	IR-Cut 680
IP class	IP30
Lens mount(s)	M58x0.75
Weight	380 g

## On-board memory and FPGA

Image buffer (RAM)	448 MByte
--------------------	-----------

## Interfaces

Digital interface	10gige
Interface connector	(RJ-45)

## FW features - image control

Exposure modes	Manual, Auto
Gain modes	Auto, Manual
White balance modes	auto, manual
Image control features	FW Features - Image Control

## FW features - camera control

Trigger modes/sync	INTERNAL,SOFTWARE,EXTERNAL
--------------------	----------------------------

## FW features - camera control

Camera control features

User Sets, POE, PWM(4), Sequencer,

Quantum Efficiency

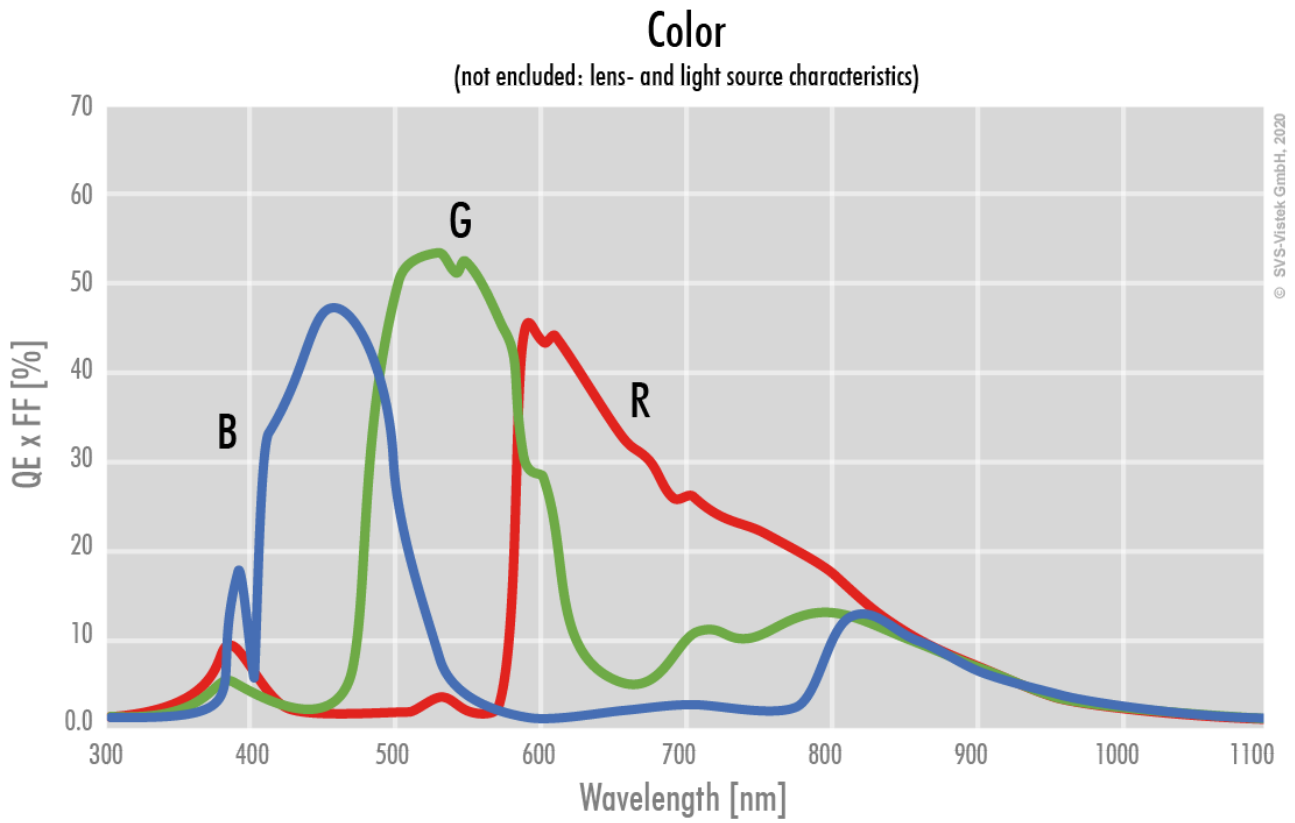

Technical Drawing

front

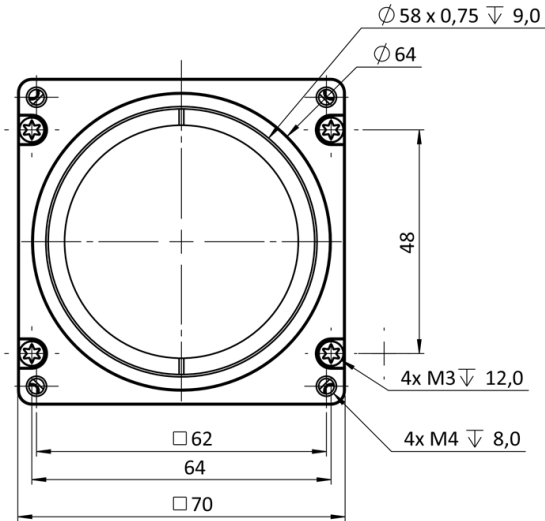

back

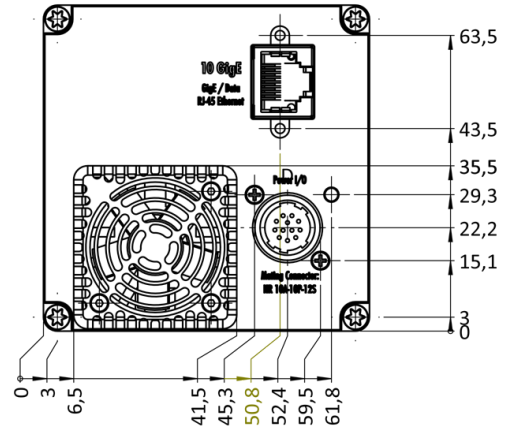

cross section

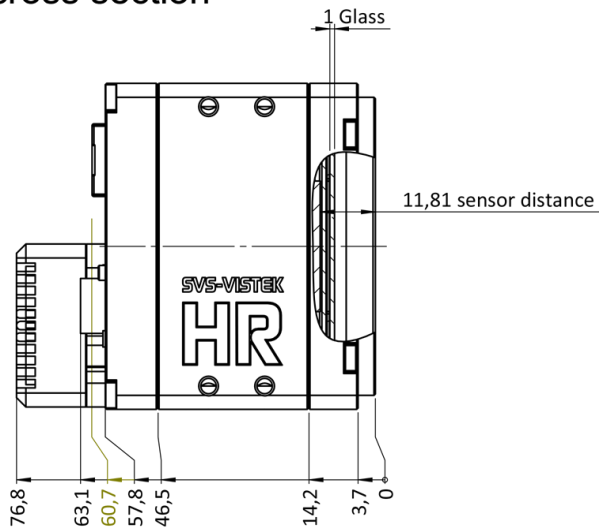

right side

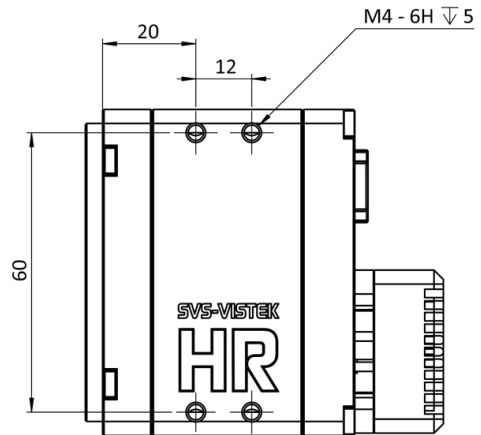

top

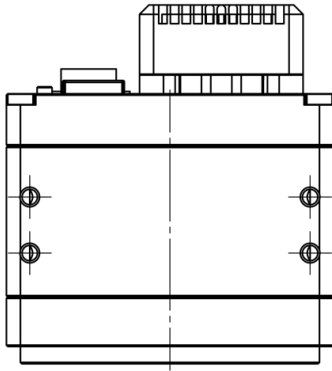

bottom

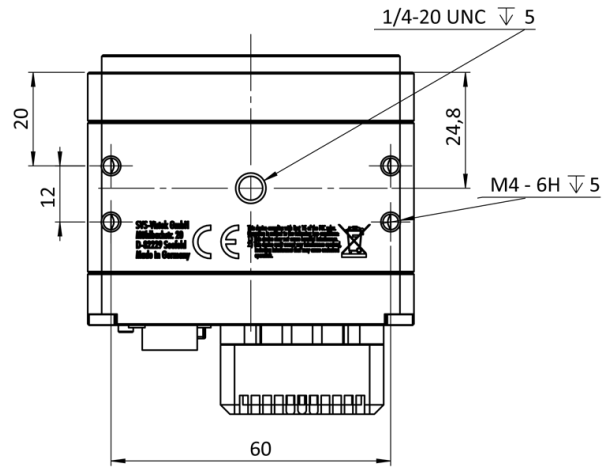

3D

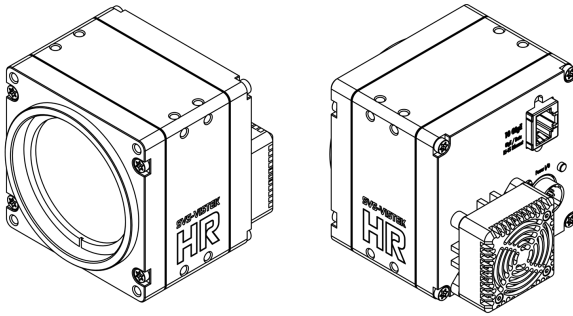

## I/O pin assignment



Hirose 12 Pin	
1	VIN - (GND)
2	VIN + (10V to 25V DC)
3	IN 4 (RXD RS232)
4	OUT 4 (TXD RS232)
5	IN 1 (0-24V)
6	IN 2 (0-24V)
7	OUT 1 (open drain)
8	OUT 2 (open drain)
9	IN 3 + (opto In +)
10	IN 3 - (opto In -)
11	OUT 3 (open drain)
12	OUT 0 (open drain)