

HR 10GigE

hr51MXGE



General

Model:	hr51MXGE
Product code:	F004100
Product series:	HR 10GigE
Status:	Available

Sensor

Sensor type:	Area scan
Chroma:	Mono
Spectrum:	Visible
Spectral range:	400 nm to 1000 nm
Resolution:	8,424 × 6,032 (51.00 MP)
Sensor model:	Gpixel GMAX4651
Sensor architecture (material):	cmos
Shutter type(s):	global-shutter
Sensor size:	38.75 × 27.75 mm (47.66 mm, 35mm Full Frame)
Pixel size:	4.60 μm × 4.60 μm

Pixel formats

Sensor bit depth:	8-Bit, 12-Bit
Monochrome pixel formats:	mono8, mono12

Imaging performance

Dynamic range:	65 dB
SNR:	42.6 dB

Timing and gain

Max. frame rate:	23.7 fps
Exposure time:	17 μ s to 60 s
Gain:	0.0 dB to 40.0 dB

I/Os and power

Non-isolated lines:	0 x LVDS input, 0 x LVDS output, 0 x TTL input, 0 x TTL output, 2 x 24V input, 4 x Open drain output,
Specific non-isolated lines:	1 x RS232 input, 1 x RS232 output, 0 x RS422 input, 0 x RS422 output,
Opto-isolated lines:	1 x Optical isolated input, 0 x Optical isolated input,
Power supply:	10 to 25VDC, Power over Ethernet (POE+, in option -P)
Power consumption:	External: 17 W (typical)

Mechanical properties

Body dimensions (L x W x H in mm):	77 x 70 x 70
Filter/protection glass:	N-BK7 - AR coating 380-850nm
IP class:	IP30
Lens mount(s):	M58x0.75
Weight:	380 g

On-board memory and FPGA

Image buffer (RAM):	448 MByte
---------------------	-----------

Interfaces

Digital interface:	10gige
Interface connector:	(RJ-45)

FW features - image control

Exposure modes:	Manual, Auto
Gain modes:	Auto, Manual
Image control features:	FW Features - Image Control

FW features - camera control

Trigger modes/sync:	INTERNAL,SOFTWARE,EXTERNAL
---------------------	----------------------------

FW features - camera control

Camera control features:

User Sets, POE, PWM(4), Sequencer,

Monochrome

(not included: lens- and light source characteristics)

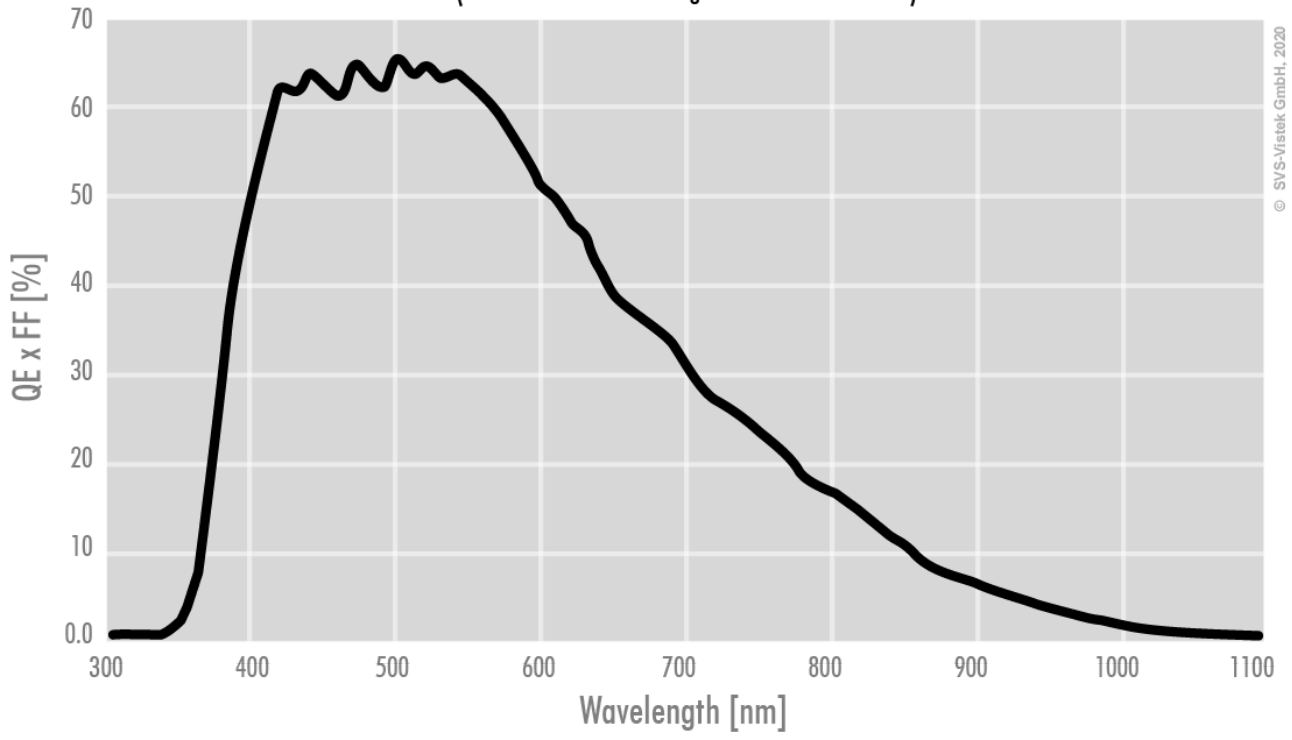

3D

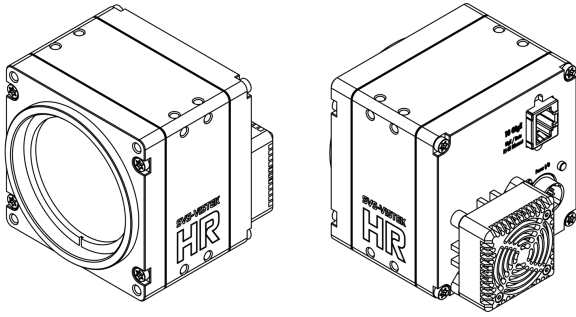

I/O pin assignment

Hirose 12 Pin



1	VIN -	(GND)	7	OUT 1	(open drain)
2	VIN +	(10 V to 25 V DC)	8	OUT 2	(open drain)
3	IN 4	(RXD RS232)	9	IN 3 +	(opto In +)
4	OUT 4	(TXD RS232)	10	IN 3 -	(opto In -)
5	IN 1	(0-24V)	11	OUT 3	(open drain)
6	IN 2	(0-24V)	12	OUT 0	(open drain)