



# HR 10GigE

hr387CXGE

## General

Model	hr387CXGE
Product code	F004076
Product series	HR 10GigE
Status	Available

## Sensor

Sensor type	Area scan
Chroma	Color
Spectrum	Visible
Spectral range	400 nm to 1000 nm
Resolution	5,440 × 3,076 (16.70 MP)
Sensor model	Sony IMX387
Sensor architecture (material)	cmos
Shutter type(s)	global-shutter
Sensor size	18.77 × 10.61 mm (21.56 mm, 21.7mm (Type 4/3))
Pixel size	3.45 μm × 3.45 μm

## Pixel formats

Sensor bit depth	8-Bit,12-Bit
RGB pixel formats	bayer8, bayer12

## Timing and gain

Max. frame rate	56.4 fps
Exposure time	21 μs to 60 s
Gain	0.0 dB to 48.0 dB

## I/Os and power

Non-isolated lines	0 x LVDS input, 0 x LVDS output, 0 x TTL input, 0 x TTL output, 2 x 24V input, 4 x Open drain output,
Specific non-isolated lines	1 x RS232 input, 1 x RS232 output, 0 x RS422 input, 0 x RS422 output,
Opto-isolated lines	1 x Optical isolated input, 0 x Optical isolated input,
Power supply	10 to 25VDC, Power over Ethernet (POE+, in option -P)
Power consumption	External: 15.5 W (typical)

## Mechanical properties

Body dimensions (L x W x H in mm)	80 × 70 × 70
Filter/protection glass	N-BK7 - AR coating
IP class	IP30
Lens mount(s)	M58x0.75
Weight	400 g

## On-board memory and FPGA

Image buffer (RAM)	448 MByte
Non-volatile memory (Flash)	32 MByte

## Interfaces

Digital interface	10gige
Interface connector	(RJ-45)

## FW features - image control

Exposure modes	Manual, Auto, External
Gain modes	Auto, Manual
White balance modes	auto, manual
Image control features	FW Features - Image Control

## FW features - camera control

Trigger modes/sync	INTERNAL,SOFTWARE,EXTERNAL
Camera control features	User Sets, POE, PWM(4), Sequencer,

Quantum Efficiency

Sensor data – excludes camera cover- or IR-cut filter characteristics

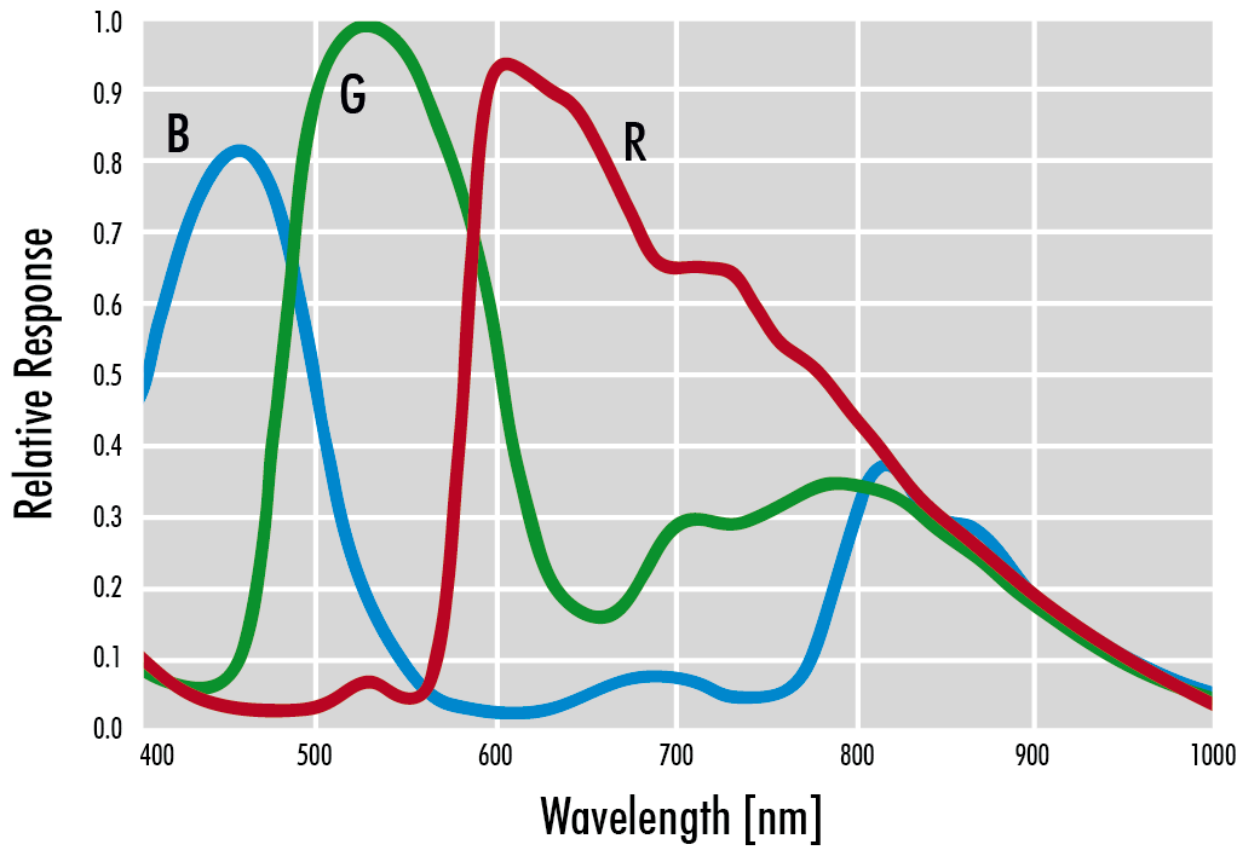

Technical Drawing

front view

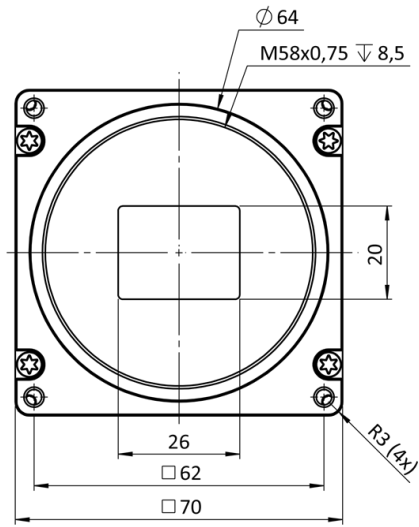

back view

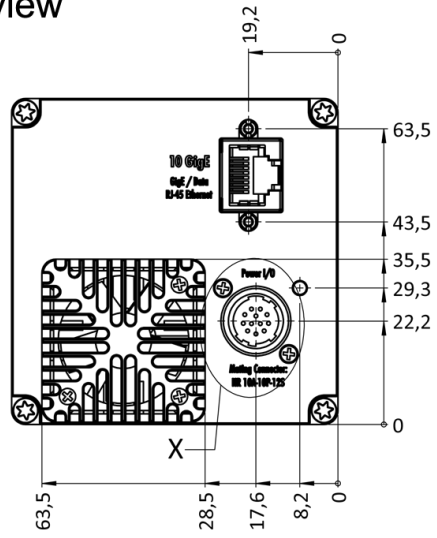

cross section

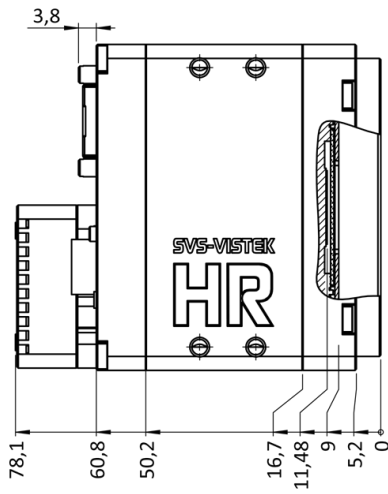

right view

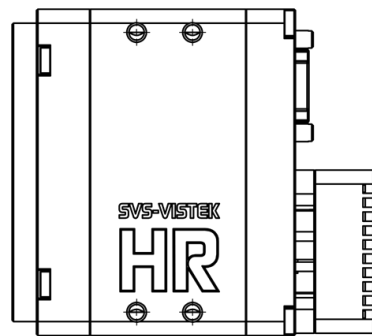

top view

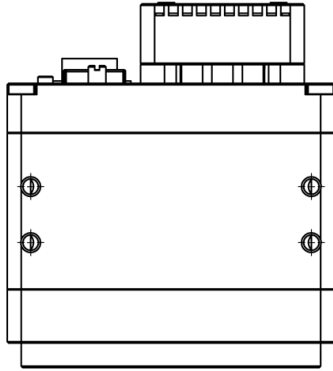

bottom view

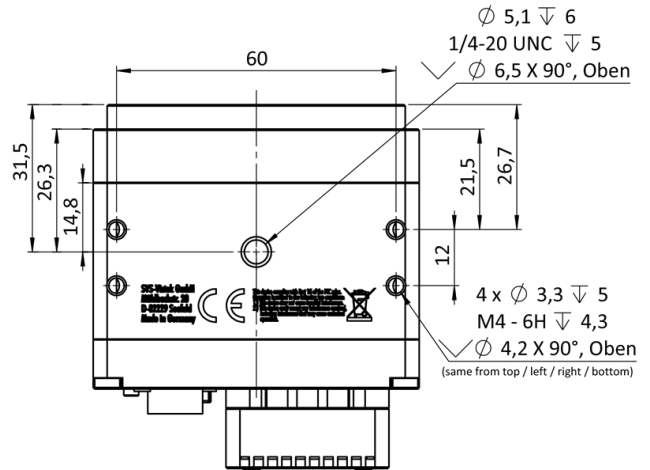

3D view

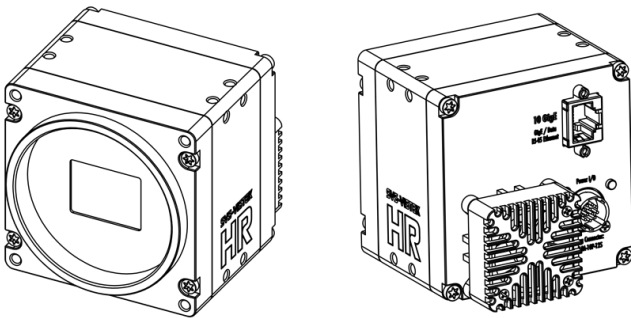

## I/O pin assignment



1	VIN - (GND)	7	OUT 1 (open drain)
2	VIN + (10V to 25V DC)	8	OUT 2 (open drain)
3	IN 4 (RXD RS232)	9	IN 3 + (opto In +)
4	OUT 4 (TXD RS232)	10	IN 3 - (opto In -)
5	IN 1 (0-24V)	11	OUT 3 (open drain)
6	IN 2 (0-24V)	12	OUT 0 (open drain)