

Goldeye CL

Goldeye CL-008 XSWIR 1.9
TEC2



Preliminary product information. Features and technical specifications are subject to change without notice.

The Goldeye CL-008 XSWIR 1.9 TEC2 is the fastest QVGA resolution short wave infrared camera with GigE Vision interface that is optimized for scientific grade applications often requiring long exposure times. With frame rates up to 344 fps at full resolution, versatile application fields can be addressed.

General

Model:	Goldeye CL-008 XSWIR 1.9 TEC2
Product series:	Goldeye CL
Status:	Prototype/engineering sample

Sensor

Sensor type:	Area scan
Chroma:	Mono
Spectrum:	eXtended SWIR, SWIR
Spectral range:	1100 nm to 1900 nm
Resolution:	320 × 256 (0.10 MP)
Sensor model:	FPA 320 × 256 30 µm Extended Range InGaAs
Sensor architecture (material):	InGaAs
Sensor size:	12.3 mm ø (12.3mm (diagonal))
Pixel size:	30.00 µm × 30.00 µm

Pixel formats

Sensor bit depth:	8-bit to 14-bit
-------------------	-----------------

Pixel formats

Monochrome pixel formats: Tap geometry 1X 1Y: Mono8, Mono10, Mono12, Mono14, Mono16, Tap geometry 1X2 1Y: Mono8

Timing and gain

Max. frame rate: 344

I/Os and power

Non-isolated lines: LVTTTL I/Os: 1 input, 1 output

Specific non-isolated lines: 115 200 Baud, 8N1 (adjustable)

Opto-isolated lines: 1 input, 2 outputs

Power supply: 10.8 V to 30.0 V

Power consumption: 20 W (at 12 VDC)

Operating conditions

Operating temperature (housing): -20 °C to 55 °C (housing)

Mechanical properties

Body dimensions (L x W x H in mm): 90 × 80 × 80

Weight: 730 g

On-board memory and FPGA

Image buffer (RAM): 256 MByte

Interfaces

Digital interface: Camera Link Base

Quantum Efficiency

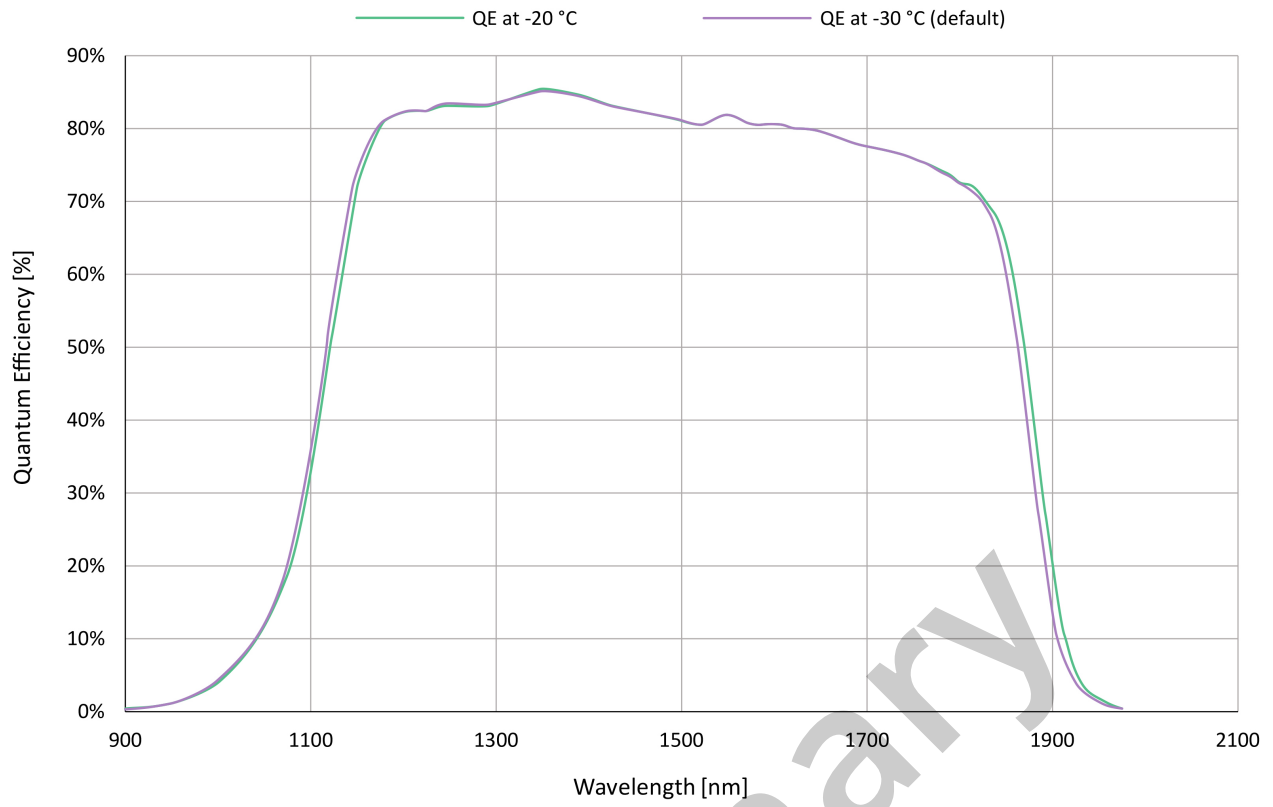

preliminary

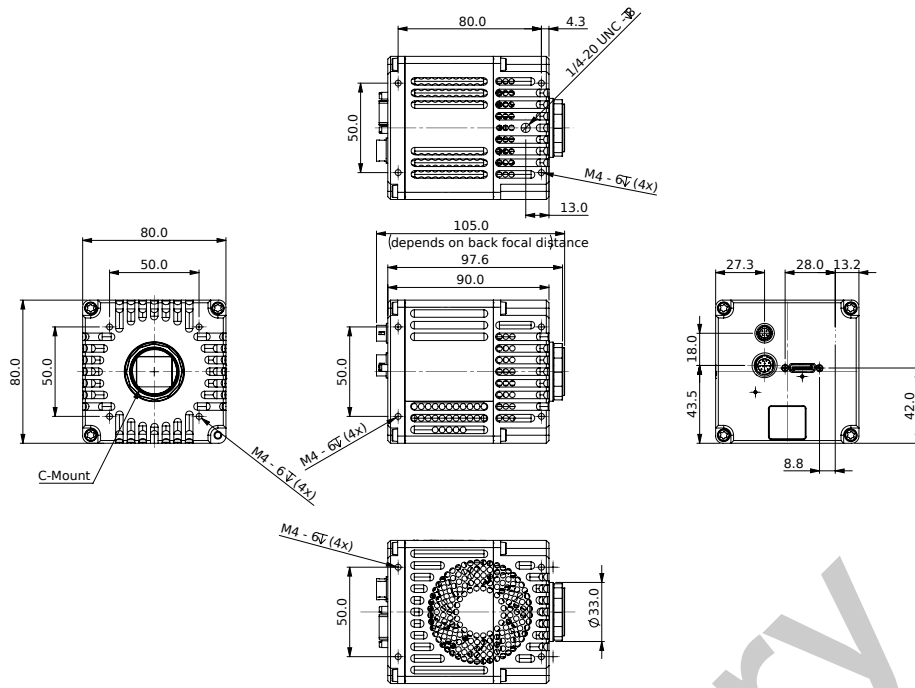

preliminary