



## General

Model:	exo273CGE
Product code:	F002194
Product series:	EXO GigE
Status:	Available

## Sensor

Sensor type:	Area scan
Chroma:	Color
Spectrum:	Visible
Spectral range:	400 nm to 1000 nm
Resolution:	1,440 × 1,080 (1.60 MP)
Sensor model:	Sony IMX273
Sensor architecture (material):	cmos
Shutter type(s):	global-shutter
Sensor size:	4.97 × 3.73 mm (6.21 mm, 6.3mm (Type 1/2.9))
Pixel size:	3.45 μm × 3.45 μm

## Pixel formats

Sensor bit depth:	8-Bit,12-Bit,12-Bit
RGB pixel formats:	bayer8, bayer12packed

## Timing and gain

Max. frame rate:	79 fps
Max. frame rate burst:	167.3 fps
Exposure time:	19 $\mu$ s to 60 s
Gain:	0.0 dB to 48.0 dB

## I/Os and power

Non-isolated lines:	0 x LVDS input, 0 x LVDS output, 0 x TTL input, 0 x TTL output, 2 x 24V input, 4 x Open drain output,
Specific non-isolated lines:	1 x RS232 input, 1 x RS232 output, 0 x RS422 input, 0 x RS422 output,
Opto-isolated lines:	1 x Optical isolated input, 0 x Optical isolated input,
Power supply:	10 to 25VDC, Power over Ethernet
Power consumption:	External: 4 W (typical)

## Operating conditions

Operating temperature (housing):	-10 °C to 60 °C
----------------------------------	-----------------

## Mechanical properties

Body dimensions (L x W x H in mm):	43 x 50 x 50
Filter/protection glass:	IR-Cut - 680nm
IP class:	IP40
Lens mount(s):	C-Mount
Weight:	138 g

## On-board memory and FPGA

Image buffer (RAM):	192 MByte
Non-volatile memory (Flash):	32 MByte

## Interfaces

Digital interface:	gige
Interface connector:	(RJ-45)

## FW features - image control

Exposure modes:	Manual, Auto, External
Gain modes:	Auto, Manual
White balance modes:	auto, manual
Image control features:	FW Features - Image Control

## FW features - camera control

Trigger modes/sync: INTERNAL,SOFTWARE,EXTERNAL

Camera control features: PTP, BurstMode, User Sets, POE, PWM(4), Sequencer,

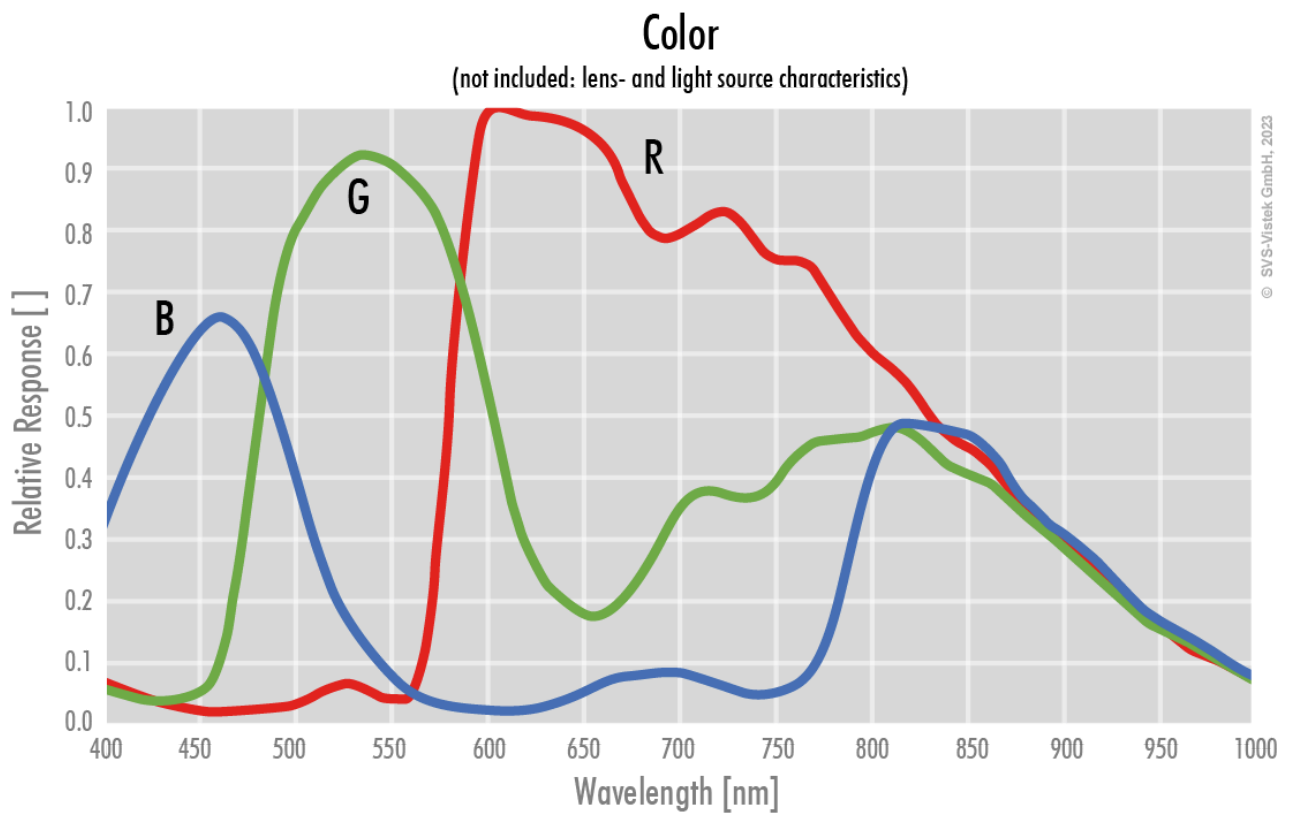

front

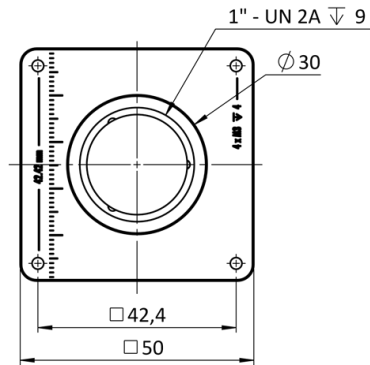

back

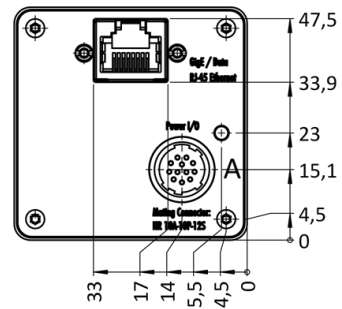

cross section

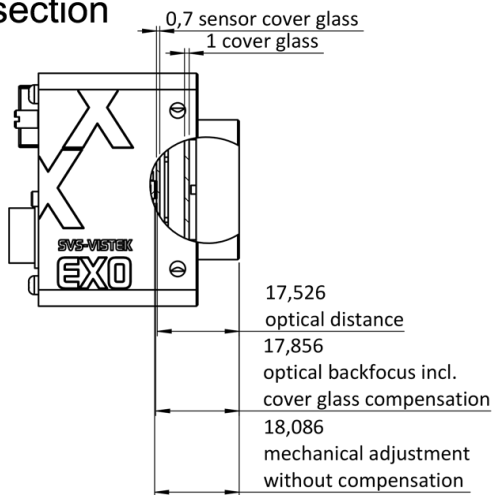

right side

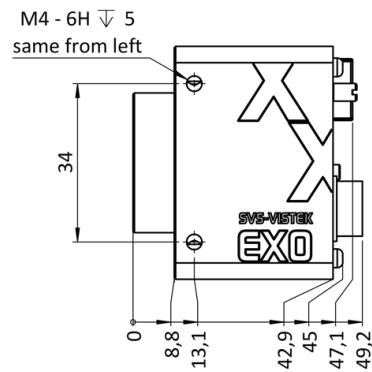

top

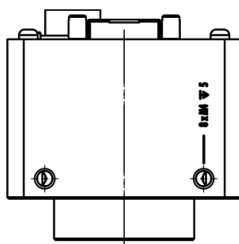

bottom

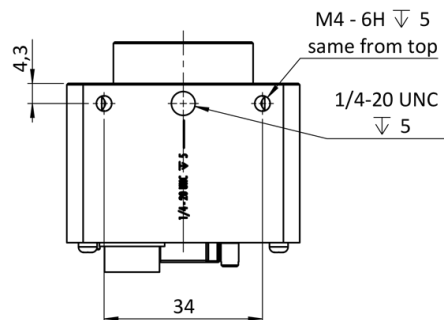

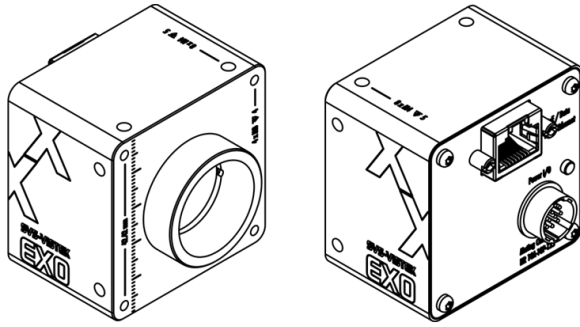

## I/O pin assignment



Hirose 12 Pin

1	VIN - (GND)	7	OUT 1 (open drain)
2	VIN + (10V to 25V DC)	8	OUT 2 (open drain)
3	IN 4 (RXD RS232)	9	IN 3 + (opto In +)
4	OUT 4 (TXD RS232)	10	IN 3 - (opto In -)
5	IN 1 (0-24V)	11	OUT 3 (open drain)
6	IN 2 (0-24V)	12	OUT 0 (open drain)