

# EXO GigE

## exo304MGE



### General

Model	exo304MGE
Product code	F002149
Product series	EXO GigE
Status	Available

### Sensor

Sensor type	Area scan
Chroma	Mono
Spectrum	Visible
Spectral range	400 nm to 1000 nm
Resolution	4,096 × 3,000 (12.30 MP)
Sensor model	Sony IMX304
Sensor architecture (material)	cmos
Shutter type(s)	global-shutter
Sensor size	14.13 × 10.35 mm (17.52 mm, 17.6mm (Type 1.1))
Pixel size	3.45 μm × 3.45 μm

### Pixel formats

Sensor bit depth	8-Bit,12-Bit,12-Bit
Monochrome pixel formats	mono8, mono12packed

### Imaging performance

Dynamic range	72 dB
SNR	39.5 dB

## Timing and gain

Max. frame rate	10 fps
Max. frame rate burst	23.6 fps
Exposure time	28 µs to 60 s
Gain	0.0 dB to 48.0 dB

## I/Os and power

Non-isolated lines	0 x LVDS input, 0 x LVDS output, 0 x TTL input, 0 x TTL output, 2 x 24V input, 4 x Open drain output,
Specific non-isolated lines	1 x RS232 input, 1 x RS232 output, 0 x RS422 input, 0 x RS422 output,
Opto-isolated lines	1 x Optical isolated input, 0 x Optical isolated input,
Power supply	10 to 25VDC, Power over Ethernet
Power consumption	External: 5 W (typical)

## Operating conditions

Operating temperature (housing)	-10 °C to 60 °C
---------------------------------	-----------------

## Mechanical properties

Body dimensions (L x W x H in mm)	43 × 50 × 50
Filter/protection glass	K9 - AR coating - 400-850nm
IP class	IP40
Lens mount(s)	C-Mount
Weight	140 g

## On-board memory and FPGA

Image buffer (RAM)	192 MByte
Non-volatile memory (Flash)	32 MByte

## Interfaces

Digital interface	gige
Interface connector	(RJ-45)

## FW features - image control

Exposure modes	Manual, Auto, External
Gain modes	Auto, Manual

## FW features - image control

Image control features

FW Features - Image Control

## FW features - camera control

Trigger modes/sync

INTERNAL,SOFTWARE,EXTERNAL

Camera control features

PTP, BurstMode, User Sets, POE, PWM(4), Sequencer,

Quantum Efficiency

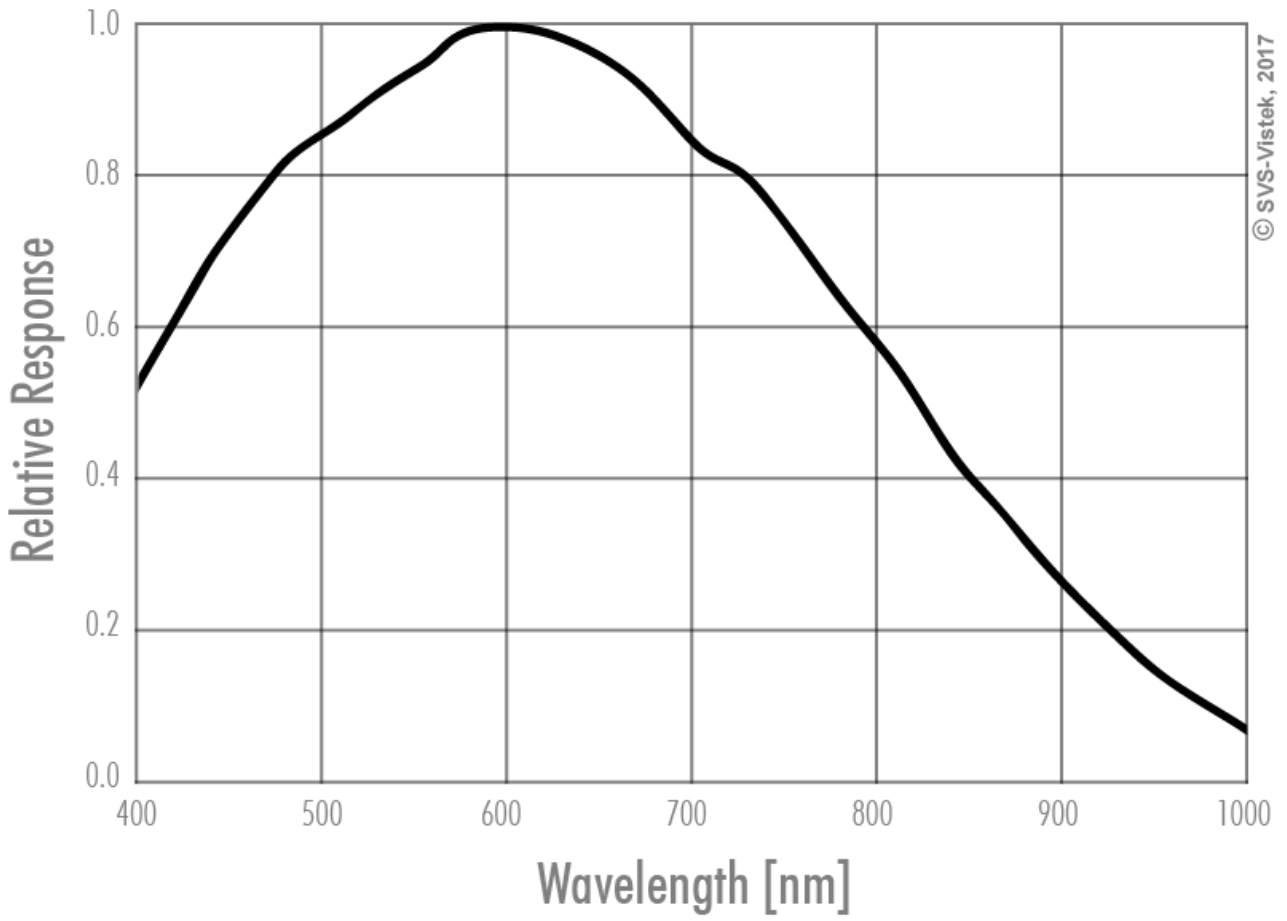

Technical Drawing

front

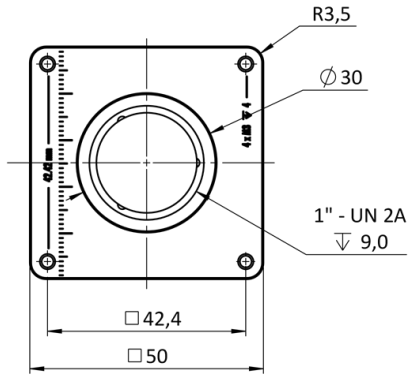

back

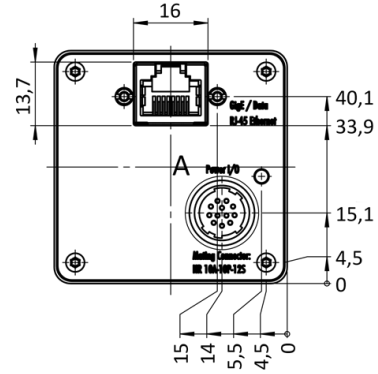

cross section

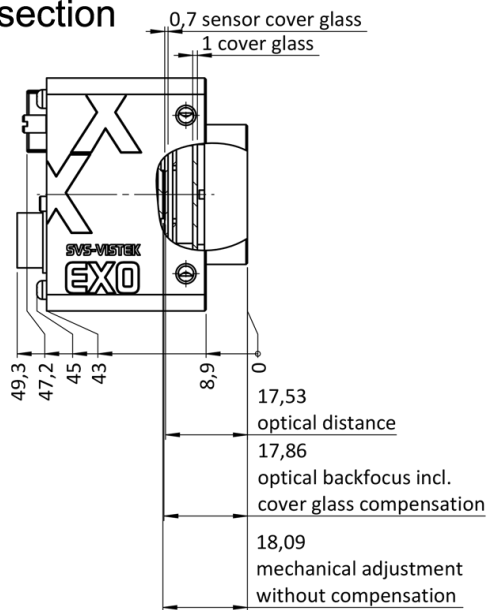

right side

right view

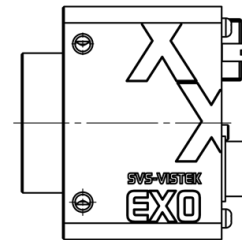

top

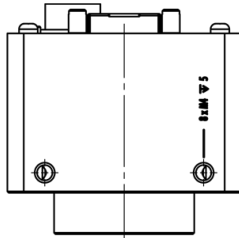

bottom

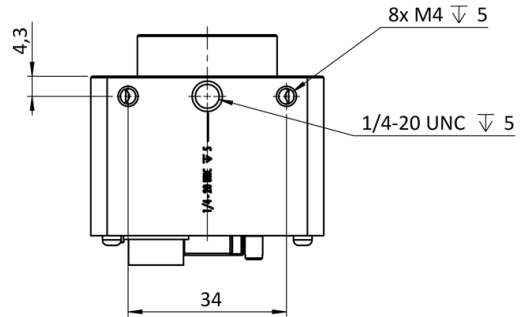

3D

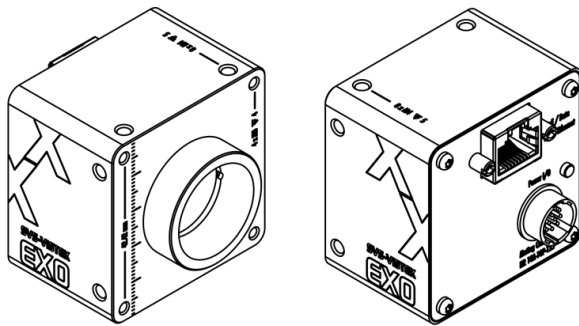

## I/O pin assignment



1	VIN - (GND)	7	OUT 1 (open drain)
2	VIN + (10V to 25V DC)	8	OUT 2 (open drain)
3	IN 4 (RXD RS232)	9	IN 3 + (opto In +)
4	OUT 4 (TXD RS232)	10	IN 3 - (opto In -)
5	IN 1 (0-24V)	11	OUT 3 (open drain)
6	IN 2 (0-24V)	12	OUT 0 (open drain)