

# EXO Tracer

exo183CGETR

## General

Model	exo183CGETR
Product code	F002209
Product series	EXO Tracer
Status	Available

## Sensor

Sensor type	Area scan
Chroma	Color
Spectrum	Visible
Spectral range	400 nm to 1000 nm
Resolution	5,496 × 3,672 (20.20 MP)
Sensor model	Sony IMX183
Sensor architecture (material)	cmos
Shutter type(s)	rolling-shutter
Sensor size	13.19 × 8.81 mm (15.86 mm, 15.86mm (Type 1))
Pixel size	2.40 μm × 2.40 μm

## Pixel formats

Sensor bit depth	8-Bit,12-Bit,12-Bit
RGB pixel formats	bayer8, bayer12packed

## Imaging performance

Dynamic range	71.5 dB
SNR	40 dB

## Timing and gain

Max. frame rate	6 fps
Max. frame rate burst	16 fps
Exposure time	30 μs to 60 s
Gain	0.0 dB to 27.0 dB

## I/Os and power

Non-isolated lines	0 x LVDS input, 0 x LVDS output, 0 x TTL input, 0 x TTL output, 2 x 24V input, 4 x Open drain output,
Specific non-isolated lines	1 x RS232 input, 1 x RS232 output, 0 x RS422 input, 0 x RS422 output,
Opto-isolated lines	1 x Optical isolated input, 0 x Optical isolated input,
Power supply	10 to 25VDC, Power over Ethernet
Power consumption	External: 7 W (typical)

## Operating conditions

Operating temperature (housing)	-10 °C to 60 °C
---------------------------------	-----------------

## Mechanical properties

Body dimensions (L x W x H in mm)	45 × 58 × 58
Filter/protection glass	IR-Cut - 680nm
IP class	IP40
Lens mount(s)	MFT
Weight	320 g

## On-board memory and FPGA

Image buffer (RAM)	192 MByte
Non-volatile memory (Flash)	32 MByte

## Interfaces

Digital interface	gige
Interface connector	(RJ-45)

## FW features - image control

Exposure modes	Manual, Auto
Gain modes	Auto, Manual
White balance modes	auto, manual
Image control features	FW Features - Image Control

## FW features - camera control

Trigger modes/sync	INTERNAL, SOFTWARE, EXTERNAL
Camera control features	BurstMode, User Sets, POE, PWM(4), Sequencer,



Quantum Efficiency

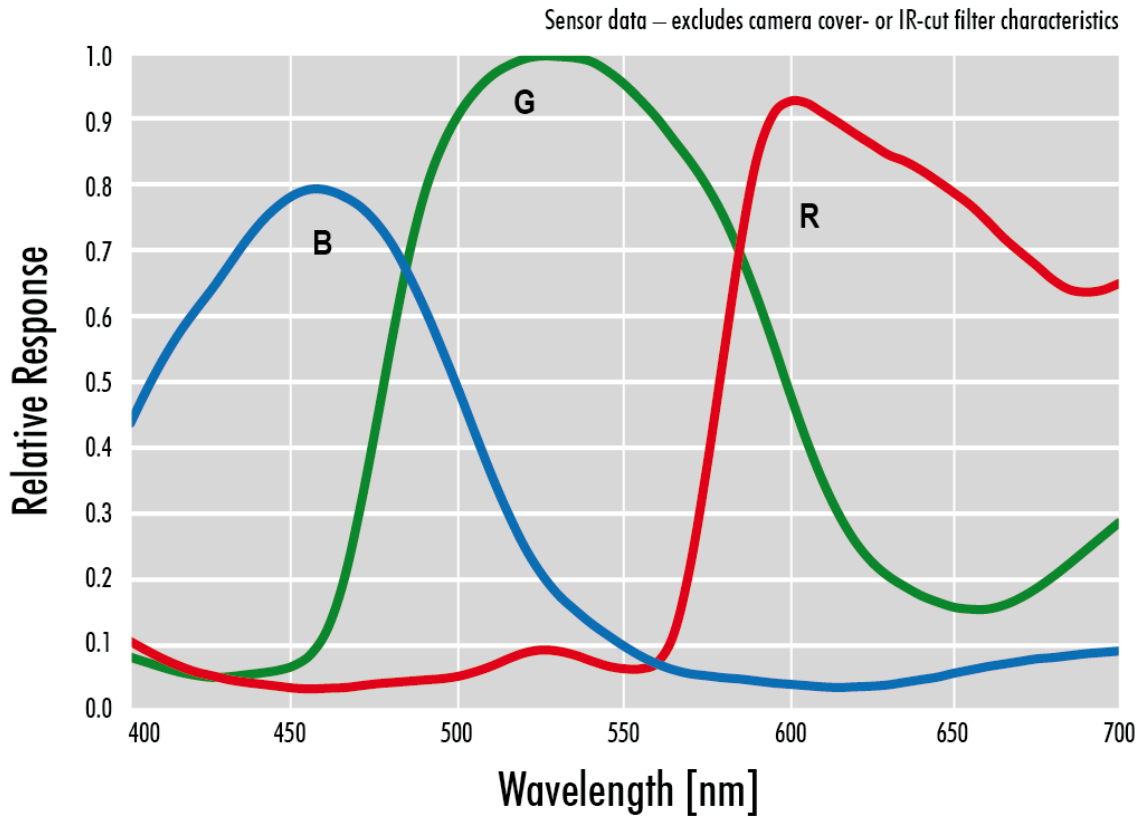

Technical Drawing

front

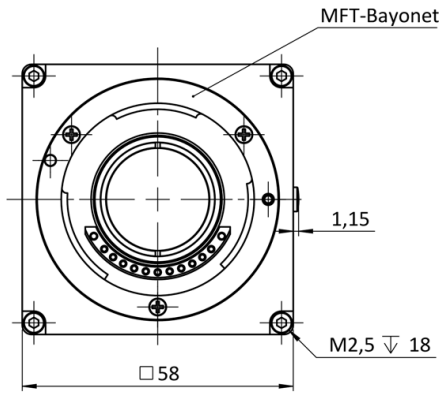

back

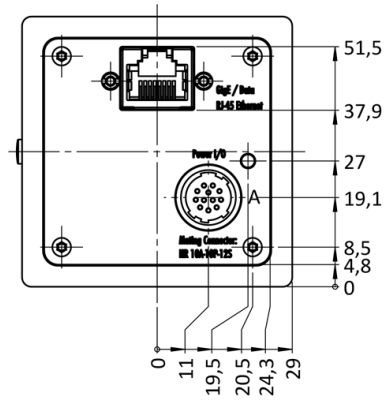

cross section

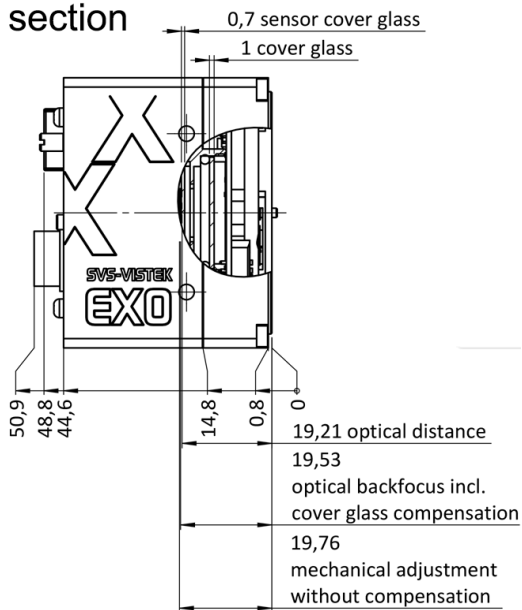

right side

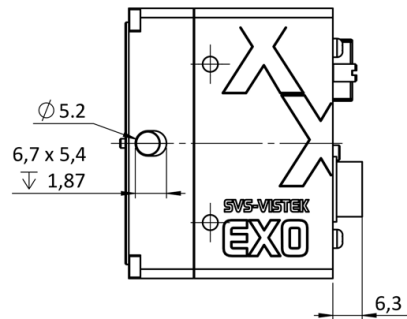

top

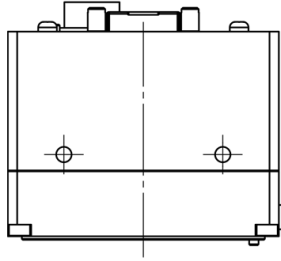

bottom

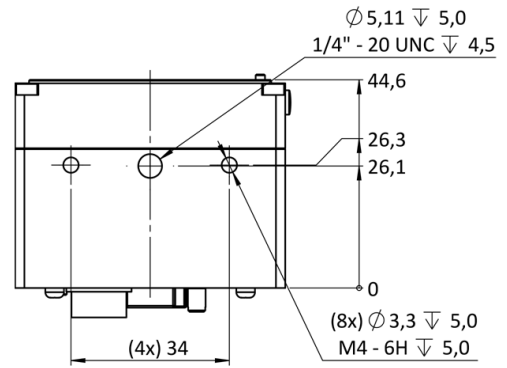

3D

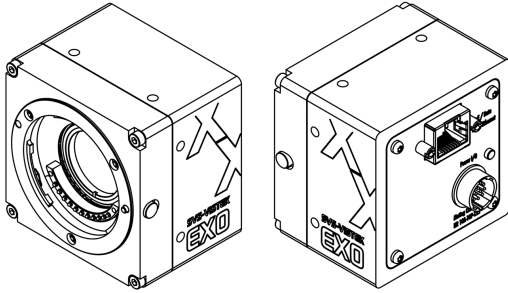

## I/O pin assignment



1	VIN - (GND)	7	OUT 1 (open drain)
2	VIN + (10 V to 25 V DC)	8	OUT 2 (open drain)
3	IN 4 (RXD RS232)	9	IN 3 + (opto In +)
4	OUT 4 (TXD RS232)	10	IN 3 - (opto In -)
5	IN 1 (0-24V)	11	OUT 3 (open drain)
6	IN 2 (0-24V)	12	OUT 0 (open drain)