

## Allgemein

Modell:	exo387MGETR
Produktcode:	F002212
Produktserie:	EXO Tracer
Status:	Available

## Sensor

Sensortyp:	Area scan
Chroma:	Mono
Spektrum:	Visible
Spektralbereich:	400 nm to 1000 nm
Auflösung:	5,456 × 3,076 (16.80 MP)
Sensormodell:	Sony IMX387LLA
Sensorarchitektur (Material):	cmos
Verschlusstyp(en):	global-shutter
Sensorgröße:	18.82 × 10.61 mm (21.61 mm, 21.7mm (Type 4/3))
Pixelgröße:	3.45 µm × 3.45 µm

## Pixelformate

Sensor-Bittiefe:	8-Bit, 12-Bit, 12-Bit
Monochrome Pixelformate:	mono8, mono12packed

## Bildgebungsleistung

Dynamikbereich:	70.5 dB
SNR:	39.9 dB

## Timing und Verstärkung

Max. Bildrate:	7.4
Max. Bildrate (Burst):	12 fps
Belichtungszeit:	41 µs to 60 s
Verstärkung:	0.0 dB to 48.0 dB

## I/Os und Stromversorgung

Nicht-isolierte Leitungen:	0 x LVDS input, 0 x LVDS output, 0 x TTL input, 0 x TTL output, 2 x 24V input, 4 x Open drain output,
Spezifische nicht-isolierte Leitungen:	1 x RS232 input, 1 x RS232 output, 0 x RS422 input, 0 x RS422 output,
Optisch isolierte Leitungen:	1 x Optical isolated input, 0 x Optical isolated output,
Stromversorgung:	10 to 25VDC, Power over Ethernet
Stromverbrauch:	External: 8 W (typical)

## Betriebsbedingungen

Betriebstemperatur (Gehäuse):	-10 °C to 65 °C
-------------------------------	-----------------

## Mechanische Eigenschaften

Gehäuseabmessungen (L x B x H in mm):	54 × 58 × 58
Filter-/Schutzglas:	K9 - AR coating
IP-Klasse:	IP40
Objektivanschluss/-anschlüsse:	MFT
Gewicht:	320 g

## Onboard-Speicher und FPGA

Bildpuffer (RAM):	192 MByte
Nichtflüchtiger Speicher (Flash):	32 MByte

## Schnittstellen

Digitale Schnittstelle:	gige
Schnittstellenanschluss:	(RJ-45)

## FW-Funktionen – Bildsteuerung

Belichtungsmodi:	Manual, Auto, External
Verstärkungsmodi:	Auto, Manual
Bildsteuerungsfunktionen:	FW Features - Image Control

## FW-Funktionen – Kamerasteuerung

Triggermodi/Synchronisation:	INTERNAL, SOFTWARE, EXTERNAL
Kamerasteuerungsfunktionen:	BurstMode, User Sets, POE, PWM(4), Sequencer,

# Monochrome

Sensor data – excludes camera cover- or IR-cut filter characteristics

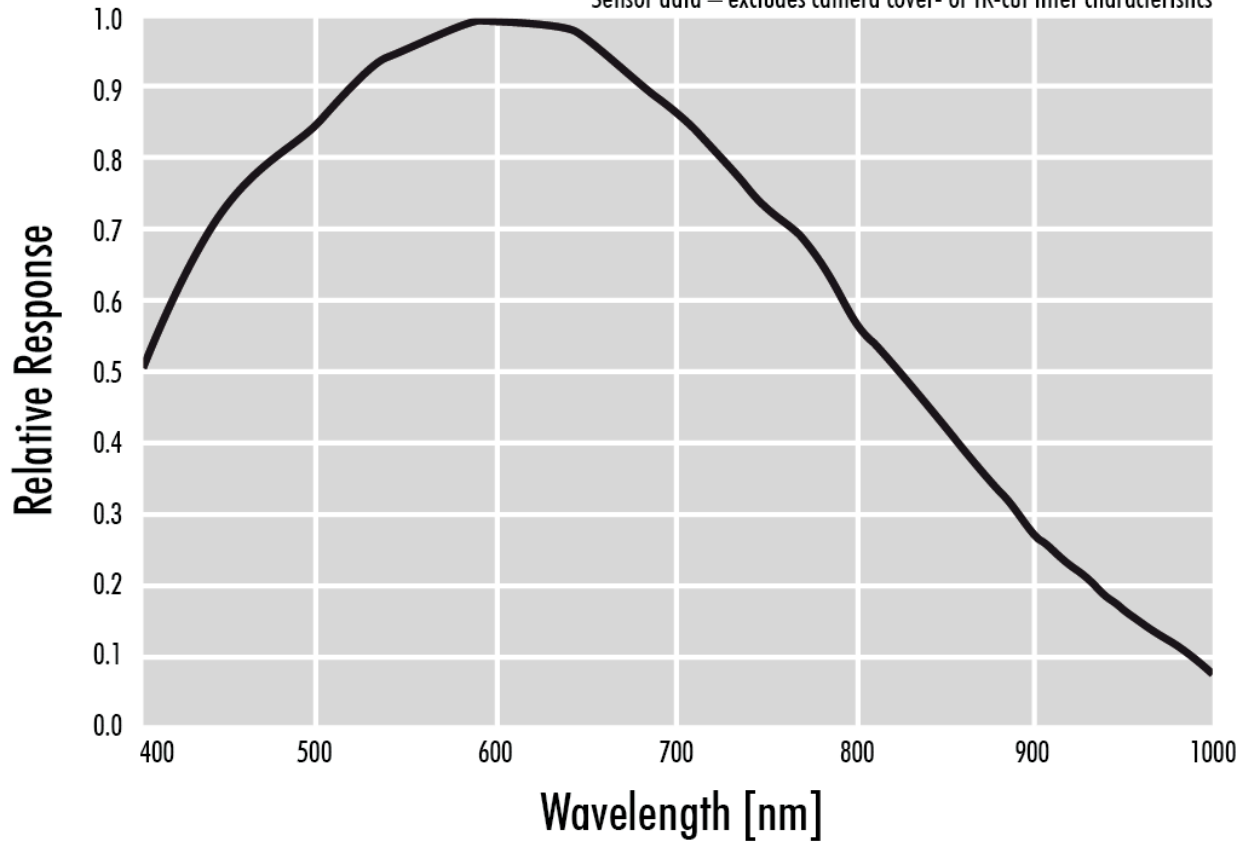

front

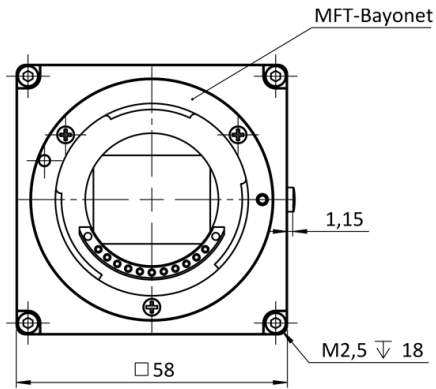

back

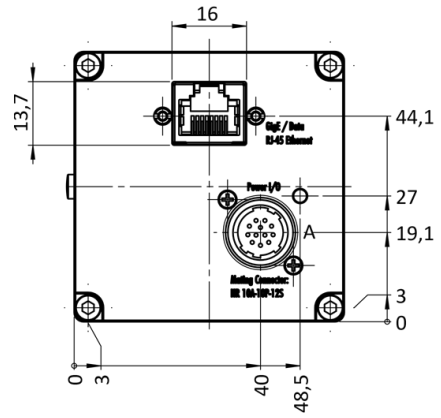

cross section

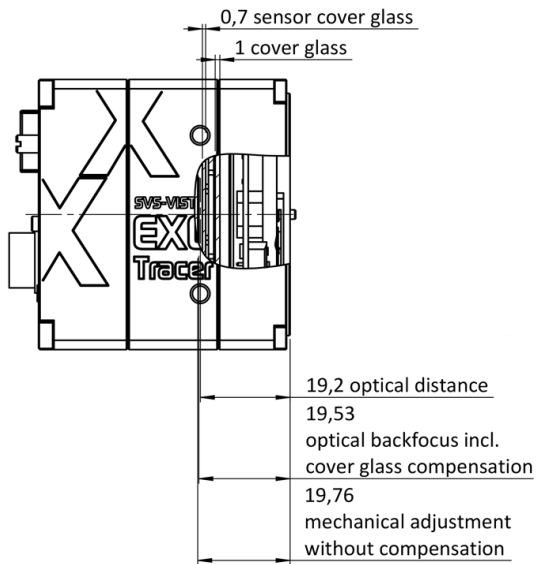

right side

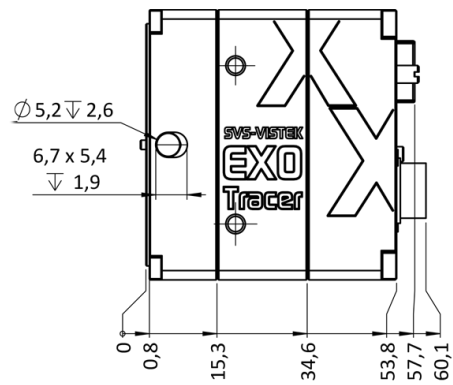

top

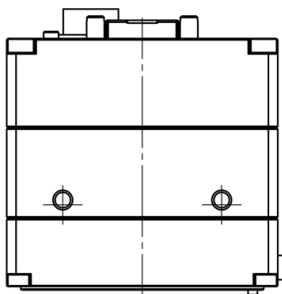

bottom

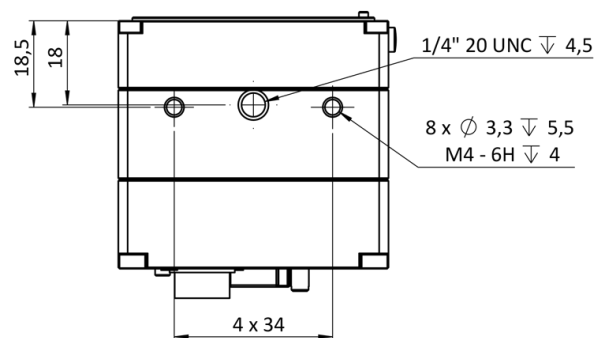

3D

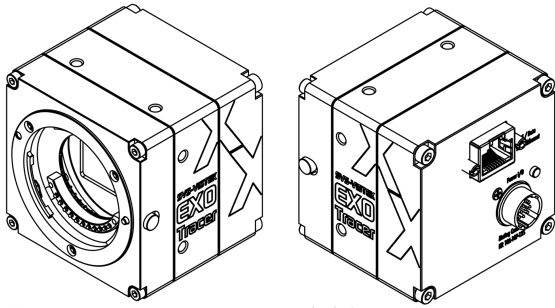

## I/O-Pin-Belegung

Hirose 12 Pin

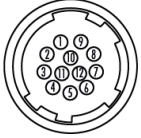

1	VIN - (GND)	7	OUT 1 (open drain)
2	VIN + (10 V to 25 V DC)	8	OUT 2 (open drain)
3	IN 4 (RXD RS232)	9	IN 3 + (opto In +)
4	OUT 4 (TXD RS232)	10	IN 3 - (opto In -)
5	IN 1 (0-24V)	11	OUT 3 (open drain)
6	IN 2 (0-24V)	12	OUT 0 (open drain)