



常规

型号:	shr661MXGE
产品代码:	F004143
产品系列:	SHR 10GigE
状态:	Available

传感器

传感器类型:	Area scan
色度:	Mono
光谱:	Visible
光谱范围:	400 nm to 1000 nm
分辨率:	13,392 × 9,528 (127.60 MP)
传感器型号:	Sony IMX661LLA
传感器架构 (材料) :	cmos
快门类型:	global-shutter
传感器尺寸:	46.2 × 32.87 mm (56.7 mm, 56.73mm (Type 3.6))
像素尺寸:	3.45 μm × 3.45 μm

像素格式

传感器位深度:	8-Bit,12-Bit,12-Bit
单色像素格式:	mono8, mono12packed

成像性能

动态范围: 74.4 dB

信噪比: 41.5 dB

时序与增益

最大帧率: 8.2

曝光时间: 163 μ s to 60 s

增益: 0.0 dB to 36.0 dB

I/O与电源

非电气隔离IO: 0 x LVDS input, 0 x LVDS output, 0 x TTL input, 0 x TTL output, 2 x 24V input, 4 x Open drain output,

特定非电气隔离IO: 1 x RS232 input, 1 x RS232 output, 0 x RS422 input, 0 x RS422 output,

光电隔离线路: 1 x Optical isolated input, 0 x Optical isolated input,

电源供应: 10 to 25VDC, Power over Ethernet (POE+, in option -P)

功耗: External: 18 W (typical)

工作条件

工作温度 (外壳): -10 °C to 60 °C

机械特性

机身尺寸 (L x W x H mm) : 83 x 80 x 80

滤光片/保护玻璃: Borofloat B270i - AR coating

IP防护等级: IP30

镜头接口: M72x0.75

重量: 580 g

板载内存与FPGA

非易失性存储器 (闪存) : 32 MByte

接口

数字接口: 10gige

接口连接器: (RJ-45)

固件功能 - 图像控制

曝光模式: Manual, Auto, External

增益模式: Auto, Manual

固件功能 - 图像控制

图像控制功能:

FW Features - Image Control

固件功能 - 相机控制

触发模式/同步:

INTERNAL, SOFTWARE, EXTERNAL

相机控制功能:

User Sets, POE, PWM(4), Sequencer,

Monochrome

(not included: lens- and light source characteristics)

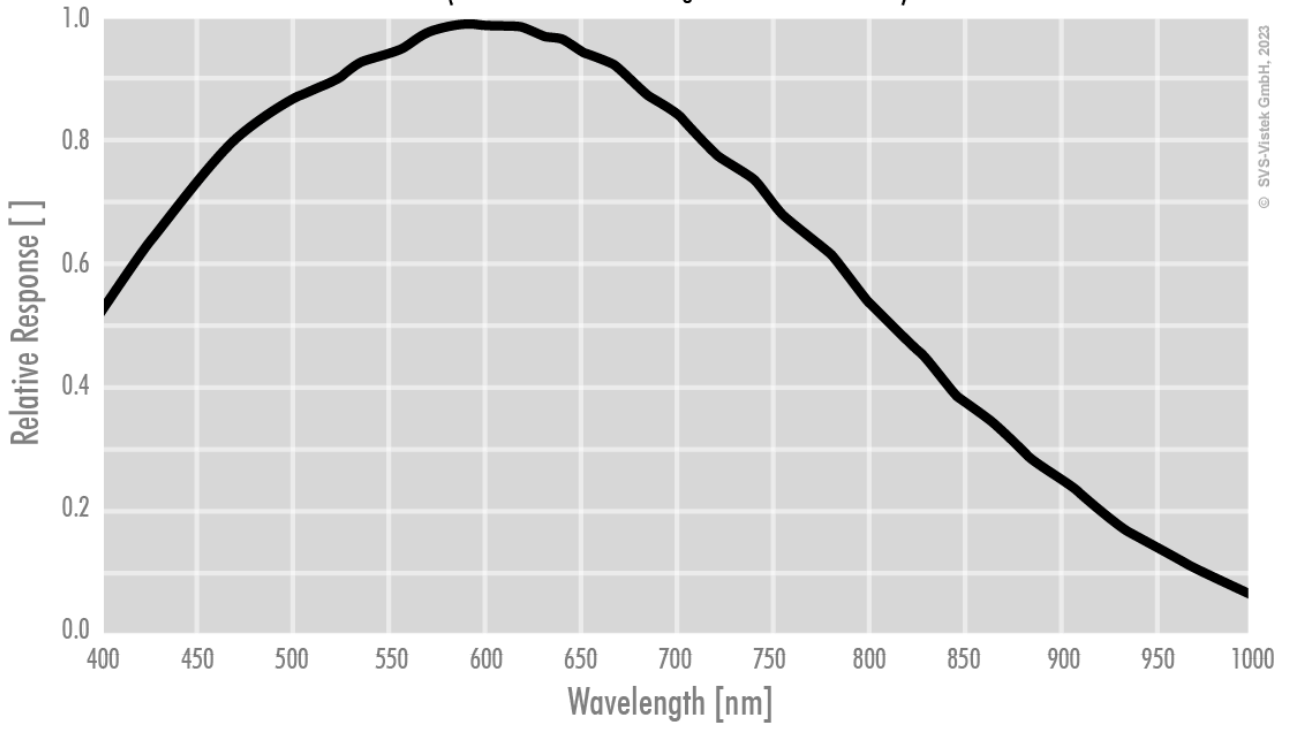

front

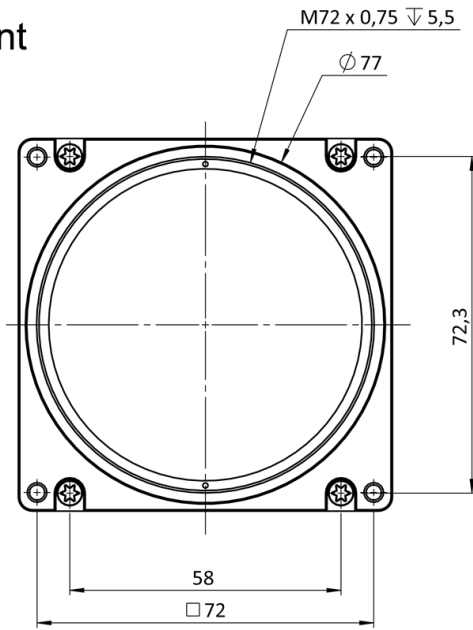

back

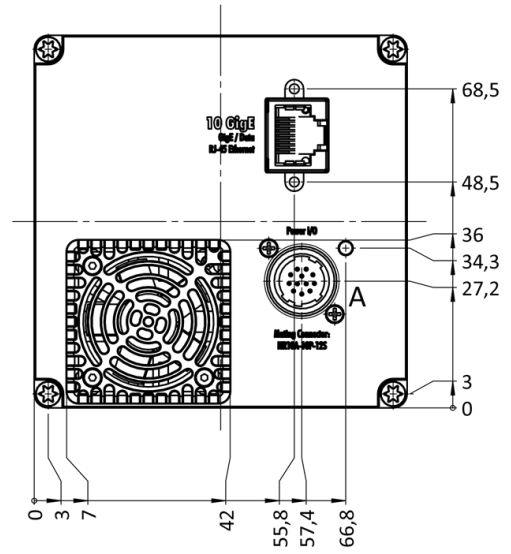

cross section

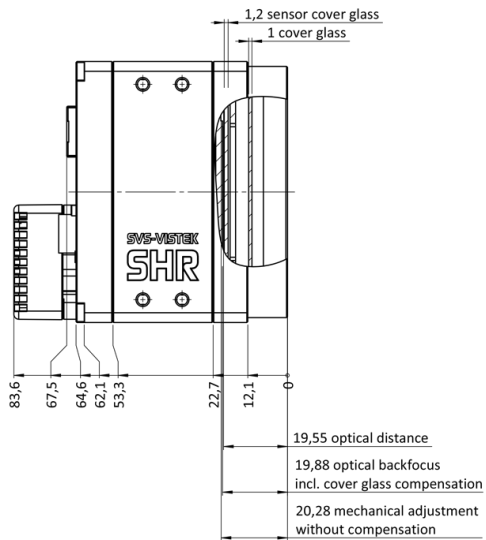

right side

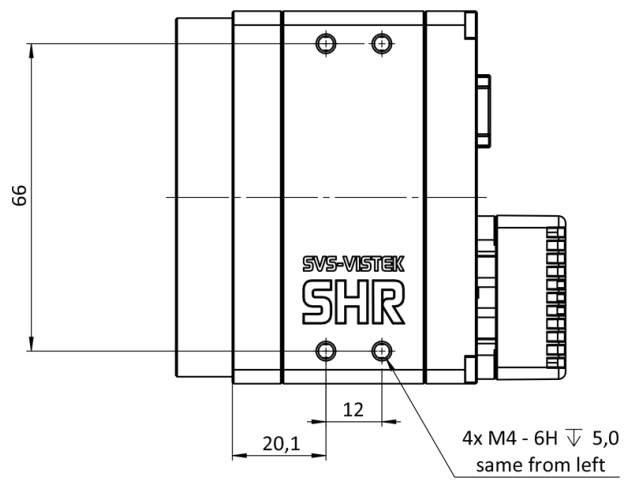

top

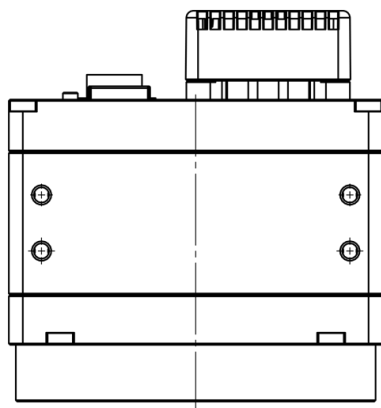

bottom

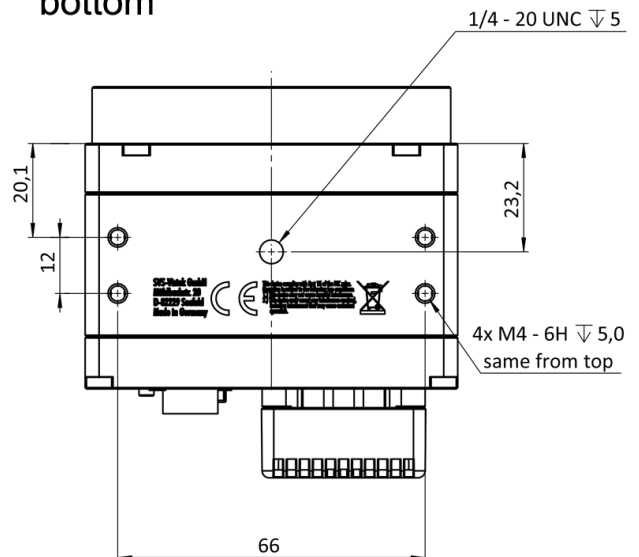

3D

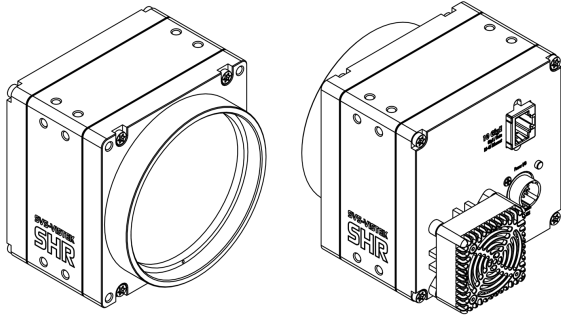

I/O pin assignment

Hirose 12 Pin



1	VIN -	(GND)	7	OUT 1	(open drain)
2	VIN +	(10 V to 25 V DC)	8	OUT 2	(open drain)
3	IN 4	(RXD RS232)	9	IN 3 +	(opto In +)
4	OUT 4	(TXD RS232)	10	IN 3 -	(opto In -)
5	IN 1	(0-24V)	11	OUT 3	(open drain)
6	IN 2	(0-24V)	12	OUT 0	(open drain)