

# HR Camera Link

hr65CCL



Preliminary product information. Features and technical specifications are subject to change without notice.

## 常规

型号:	hr65CCL
产品代码:	F004145
产品系列:	HR Camera Link
状态:	Prototype/engineering sample

## 传感器

传感器类型:	Area scan
色度:	Color
光谱:	Visible
光谱范围:	400 nm to 1000 nm
分辨率:	9,344 × 7,000 (65.00 MP)
传感器型号:	Gpixel GMAX3265
传感器架构 (材料) :	cmos
快门类型:	global-shutter
传感器尺寸:	29.9 × 22.4 mm (37.36 mm, 37.4mm)
像素尺寸:	3.20 μm × 3.20 μm

## 像素格式

传感器位深度:	8-Bit,10-Bit
RGB像素格式:	bayer8, bayer10

## 成像性能

动态范围: 65.6 dB

信噪比: 40 dB

## 时序与增益

最大帧率: 13 fps

曝光时间: 21  $\mu$ s to 60 s

增益: 0.0 dB to 18.0 dB

## I/O与电源

非电气隔离IO: 0 x LVDS input, 0 x LVDS output, 0 x TTL input, 0 x TTL output, 2 x 24V input, 4 x Open drain output,

特定非电气隔离IO: 1 x RS232 input, 1 x RS232 output, 0 x RS422 input, 0 x RS422 output,

光电隔离线路: 1 x Optical isolated input, 0 x Optical isolated input,

电源供应: 10 to 25VDC

功耗: External: 9 W (typical)

## 机械特性

机身尺寸 (L x W x H mm) : 76 x 70 x 70

滤光片/保护玻璃: IR-Cut 680

IP防护等级: IP30

镜头接口: M58x0.75

重量: 420 g

## 板载内存与FPGA

非易失性存储器 (闪存) : 32 MByte

## 接口

数字接口: camera link 80-bit

接口连接器: SDR

## 固件功能 - 图像控制

曝光模式: Manual, Auto, External

增益模式: Auto, Manual

白平衡模式: auto, manual

图像控制功能: FW Features - Image Control

## 固件功能 - 相机控制

触发模式/同步:

INTERNAL, SOFTWARE, EXTERNAL

相机控制功能:

User Sets, PWM(4), Sequencer,

preliminary

### Color

(not included: lens- and light source characteristics)

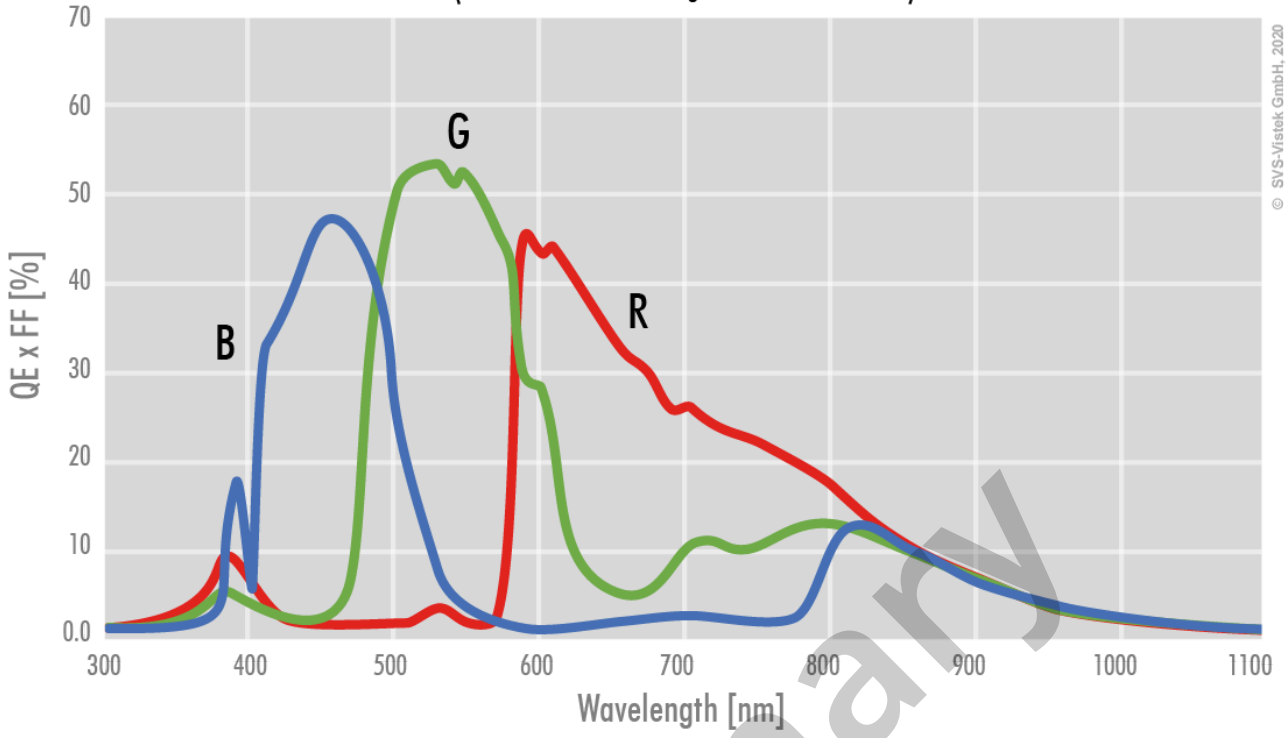

© SYS-Vistek GmbH, 2020

preliminary

front

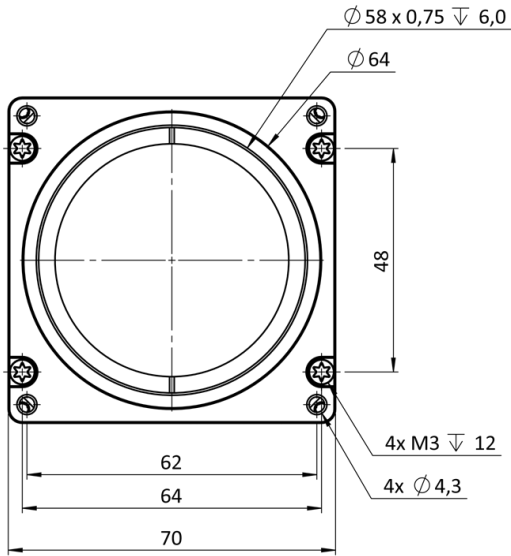

back

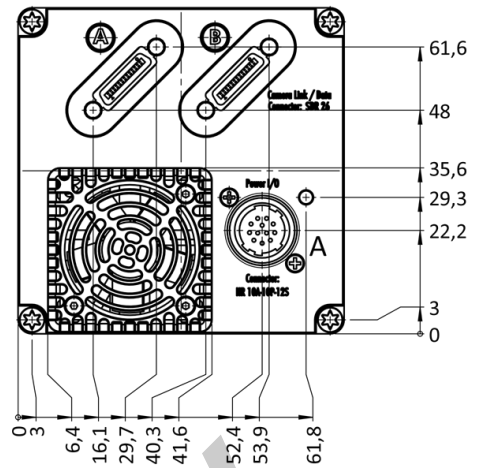

cross section

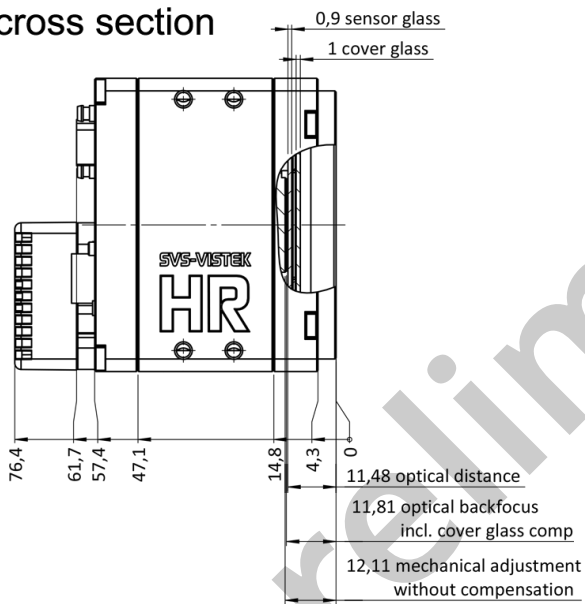

right side

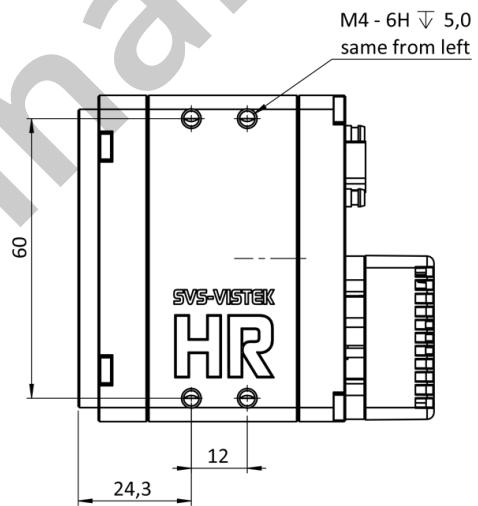

top

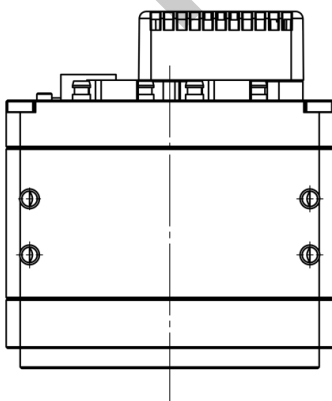

bottom

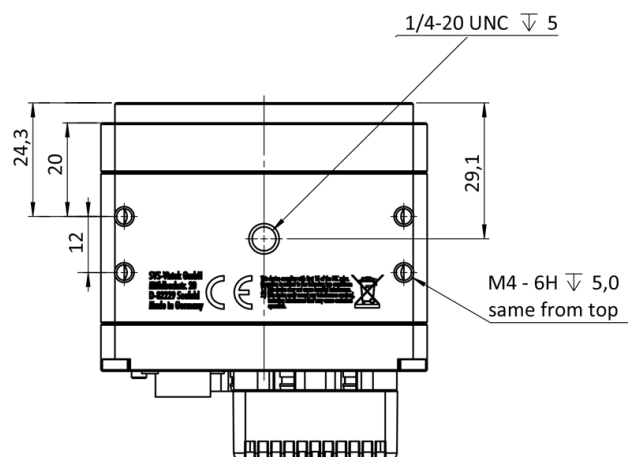

3D

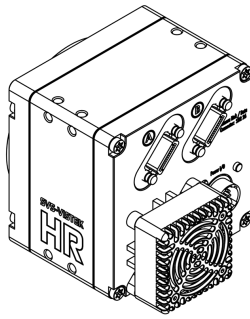
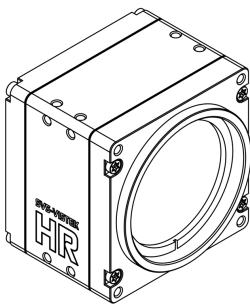

## I/O pin assignment

Hirose 12 Pin

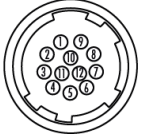

1	VIN -	(GND)	7	OUT 1	(open drain)
2	VIN +	(10 V to 25 V DC)	8	OUT 2	(open drain)
3	IN 4	(RXD RS232)	9	IN 3 +	(opto In +)
4	OUT 4	(TXD RS232)	10	IN 3 -	(opto In -)
5	IN 1	(0-24V)	11	OUT 3	(open drain)
6	IN 2	(0-24V)	12	OUT 0	(open drain)

preliminary