

HR Camera Link

hr25MCL



常规

型号:	hr25MCL
产品代码:	F004051
产品系列:	HR Camera Link
状态:	Available

传感器

传感器类型:	Area scan
色度:	Mono
光谱:	Visible
光谱范围:	400 nm to 1000 nm
分辨率:	5,120 × 5,120 (25.00 MP)
传感器型号:	ON Semiconductor NOIP1SN025KA-GDI
传感器架构 (材料) :	cmos
快门类型:	global-shutter
传感器尺寸:	23.04 × 23.04 mm (32.58 mm, 32.58mm (APS-H))
像素尺寸:	4.50 μm × 4.50 μm

像素格式

传感器位深度:	8-Bit,10-Bit
单色像素格式:	bayer8, bayer10

时序与增益

最大帧率:	31.8
曝光时间:	21 μ s to 60 s
增益:	0.0 dB to 18.0 dB

I/O与电源

非电气隔离IO:	0 x LVDS input, 0 x LVDS output, 0 x TTL input, 0 x TTL output, 2 x 24V input, 4 x Open drain output,
特定非电气隔离IO:	1 x RS232 input, 1 x RS232 output, 0 x RS422 input, 0 x RS422 output,
光电隔离线路:	1 x Optical isolated input, 0 x Optical isolated input,
电源供应:	10 to 25VDC
功耗:	External: 10 W (typical)

工作条件

工作温度 (外壳):	-10 °C to 65 °C
------------	-----------------

机械特性

机身尺寸 (L x W x H mm) :	56 x 70 x 70
IP防护等级:	IP40
镜头接口:	M58x0.75
重量:	420 g

板载内存与FPGA

非易失性存储器 (闪存) :	32 MByte
----------------	----------

接口

数字接口:	camera link 80-bit
接口连接器:	SDR

固件功能 - 图像控制

曝光模式:	Manual, Auto, External
增益模式:	Auto, Manual
图像控制功能:	FW Features - Image Control

固件功能 - 相机控制

触发模式/同步:	INTERNAL, SOFTWARE, EXTERNAL
相机控制功能:	User Sets, PWM(4), Sequencer,

Quantum Efficiency

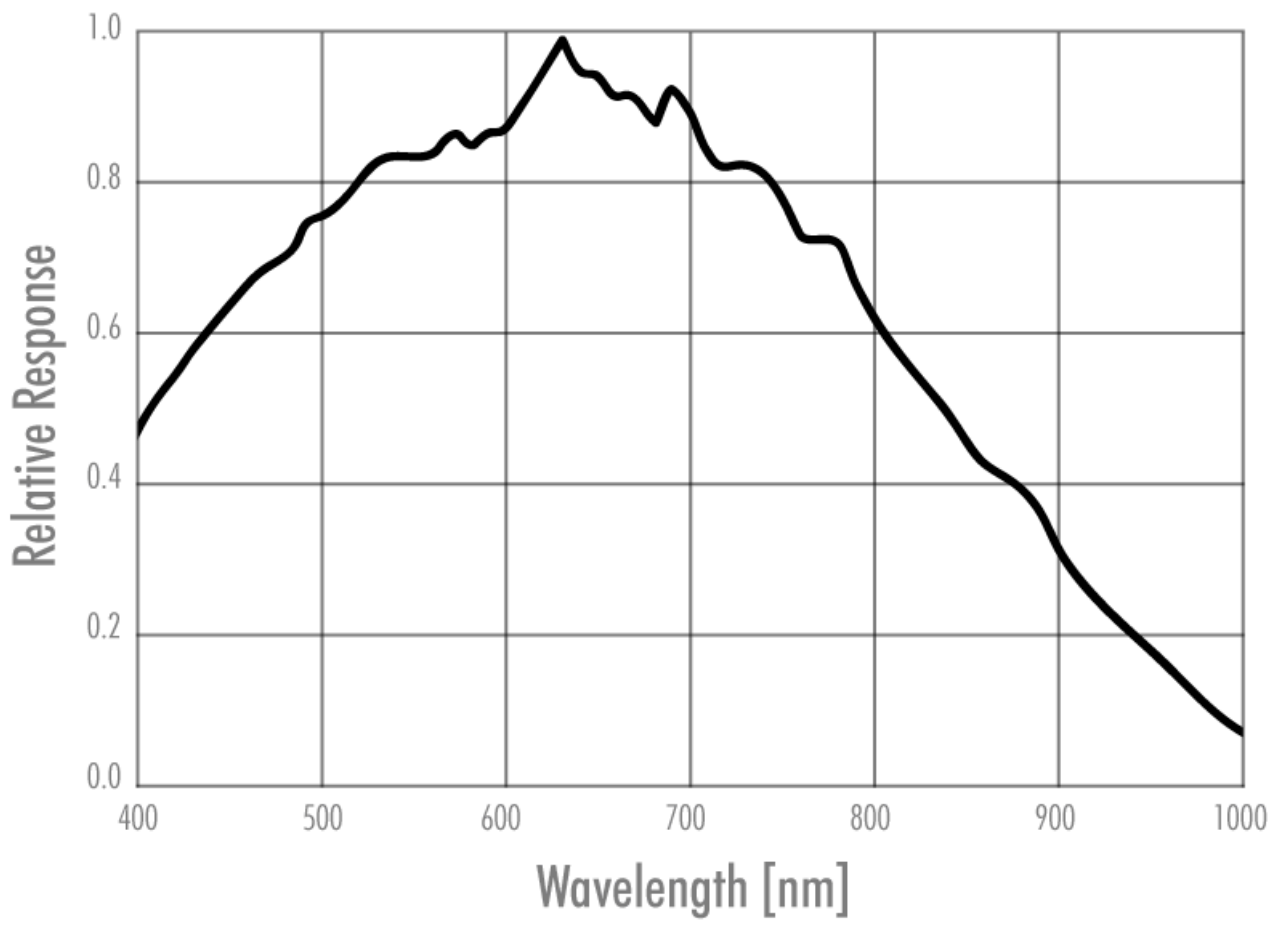

front view

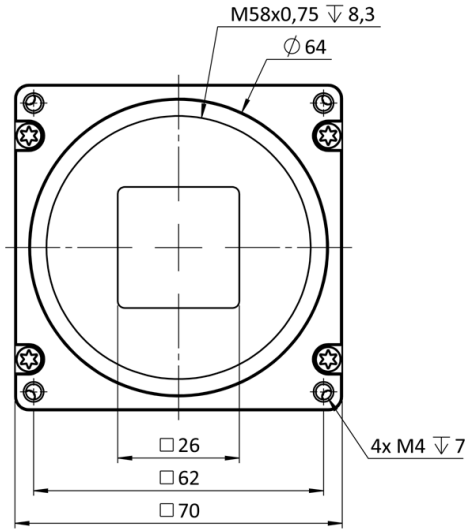

back view

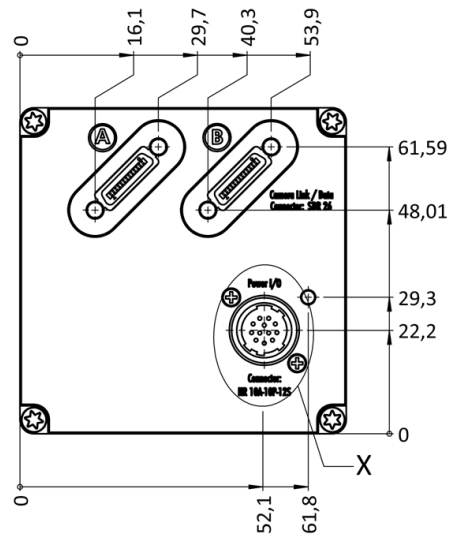

cross section

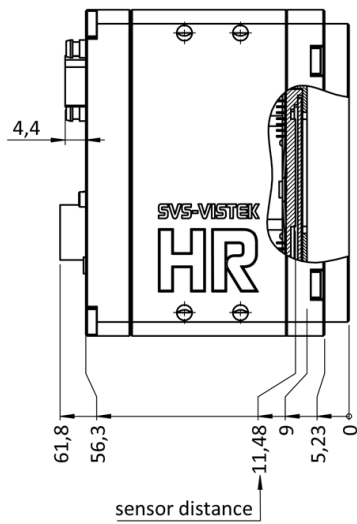

right view

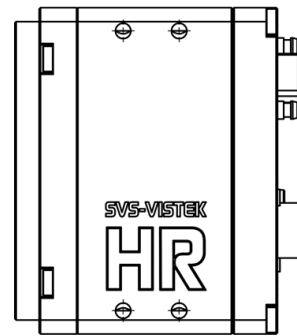

top view

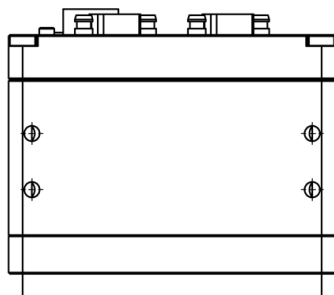

bottom view

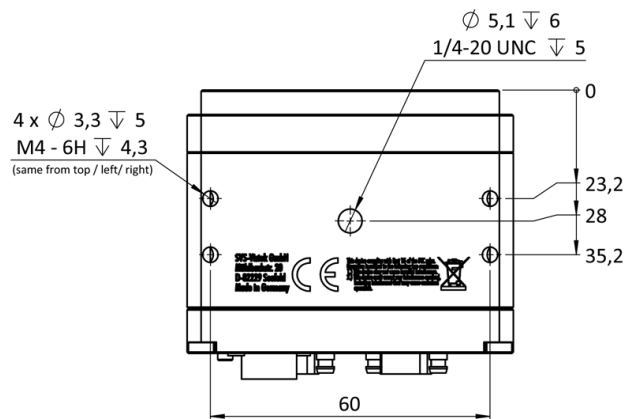

3D view

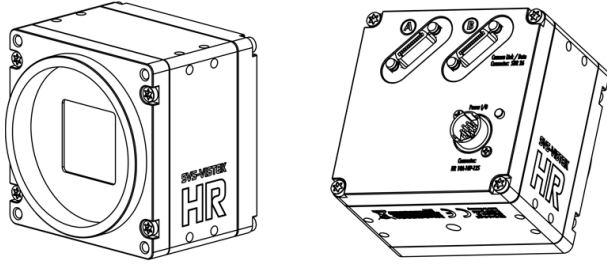

I/O pin assignment



Hirose 12 Pin

1	VIN - (GND)	7	OUT 1 (open drain)
2	VIN + (10 V to 25 V DC)	8	OUT 2 (open drain)
3	IN 4 (RXD RS232)	9	IN 3 + (opto In +)
4	OUT 4 (TXD RS232)	10	IN 3 - (opto In -)
5	IN 1 (0-24V)	11	OUT 3 (open drain)
6	IN 2 (0-24V)	12	OUT 0 (open drain)