



常规

型号:	fxo546MCX
产品代码:	F002154
产品系列:	FXO CoaXPress
状态:	Available

传感器

传感器类型:	Area scan
色度:	Mono
光谱:	Visible
光谱范围:	400 nm to 1000 nm
分辨率:	2,832 × 2,840 (8.00 MP)
传感器型号:	Sony IMX546LLA
传感器架构 (材料) :	cmos
快门类型:	global-shutter
传感器尺寸:	7.76 × 7.78 mm (10.99 mm, 11.1mm (Type 2/3))
像素尺寸:	2.74 μm × 2.74 μm

像素格式

传感器位深度:	8-Bit,12-Bit
单色像素格式:	mono8, mono12

时序与增益

最大帧率:	88
曝光时间:	7 μ s to 60 s
增益:	0.0 dB to 48.0 dB

I/O与电源

非电气隔离IO:	0 x LVDS input, 0 x LVDS output, 0 x TTL input, 0 x TTL output, 2 x 24V input, 4 x Open drain output,
特定非电气隔离IO:	1 x RS232 input, 1 x RS232 output, 0 x RS422 input, 0 x RS422 output,
光电隔离线路:	1 x Optical isolated input, 0 x Optical isolated input,
电源供应:	10 to 25VDC, Power over CoaXPress
功耗:	External: 8 W (typical)

工作条件

工作温度 (外壳):	-10 °C to 65 °C
------------	-----------------

机械特性

机身尺寸 (L x W x H mm) :	70 x 50 x 50
滤光片/保护玻璃:	K9 - AR coating - 400-850nm
IP防护等级:	IP30
镜头接口:	C-Mount
重量:	240 g

板载内存与FPGA

非易失性存储器 (闪存) :	32 MByte
----------------	----------

接口

数字接口:	cxp-12 with 1 connection
接口连接器:	(micro-BNC)

固件功能 - 图像控制

曝光模式:	Manual, Auto, External
增益模式:	Auto, Manual
图像控制功能:	FW Features - Image Control

固件功能 - 相机控制

触发模式/同步:	INTERNAL,SOFTWARE,EXTERNAL
----------	----------------------------

Monochrome

(not included: lens- and light source characteristics)

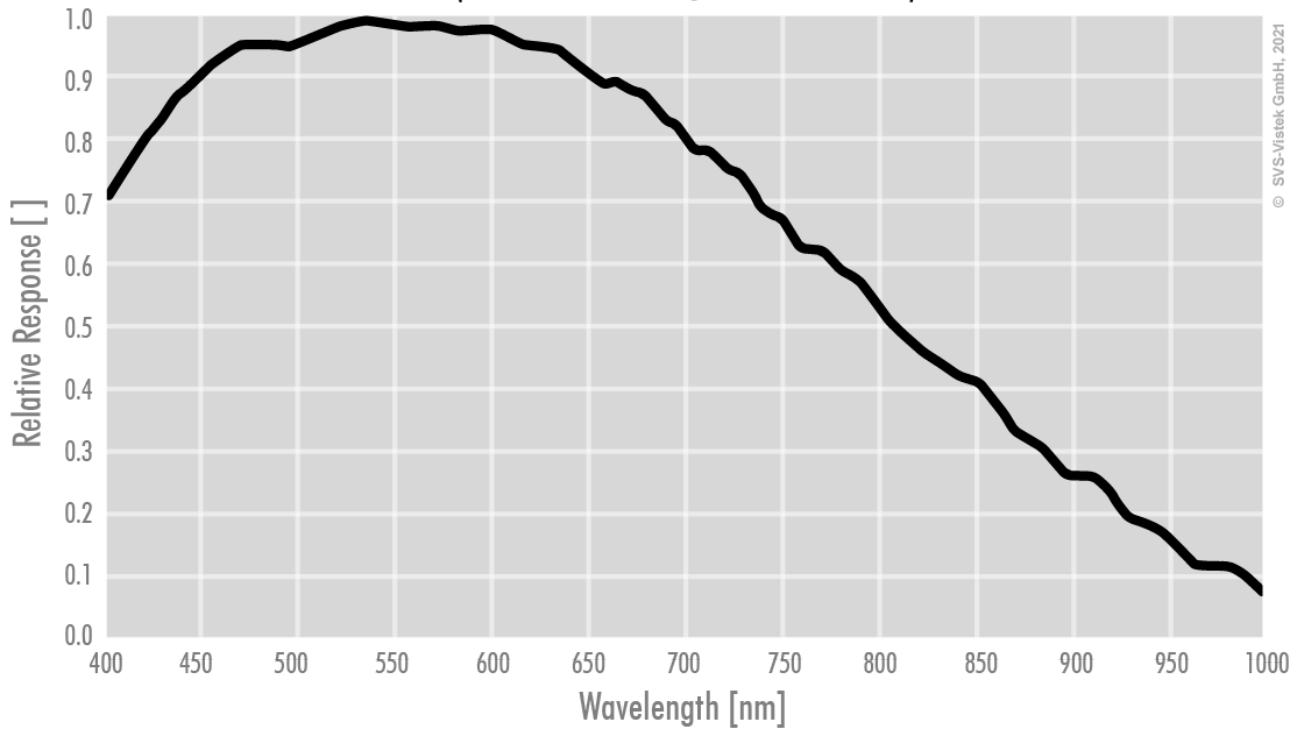

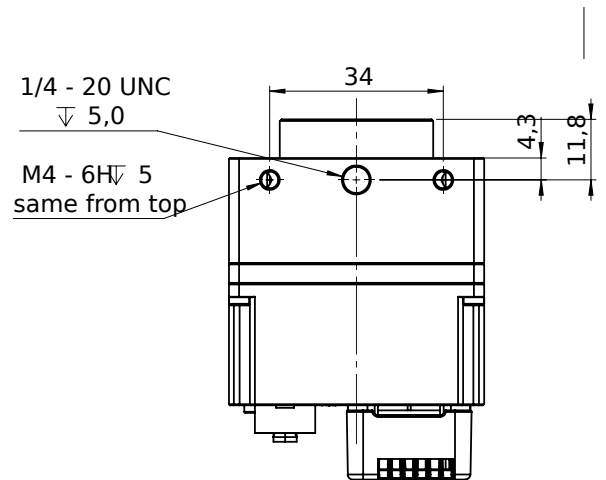
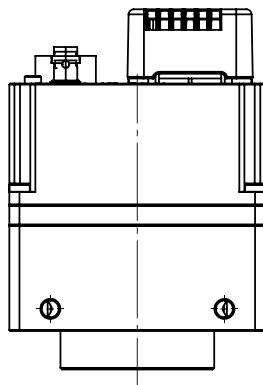
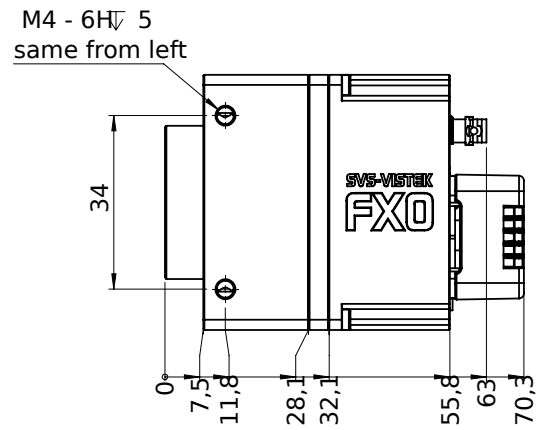
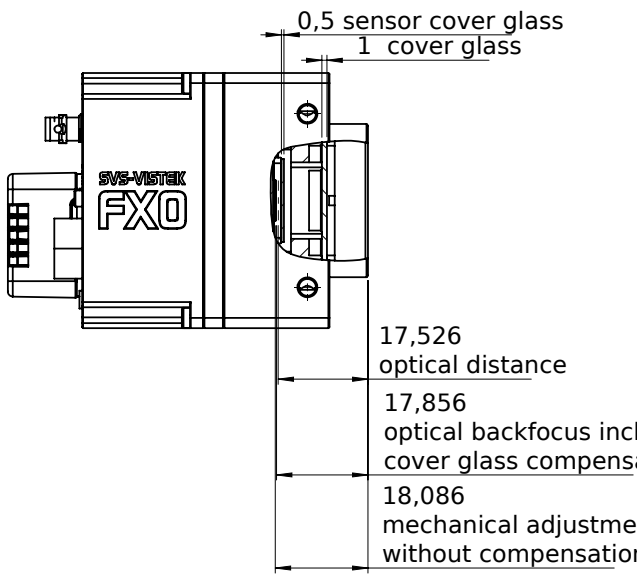
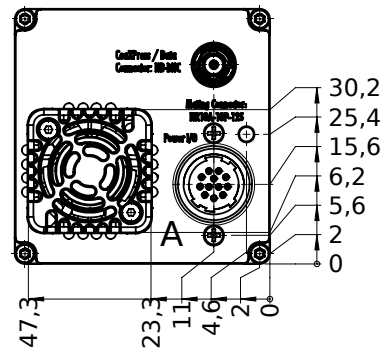
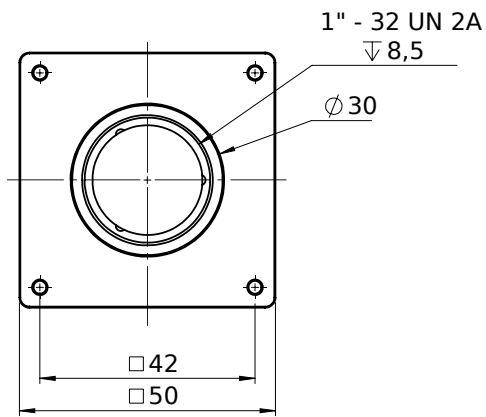

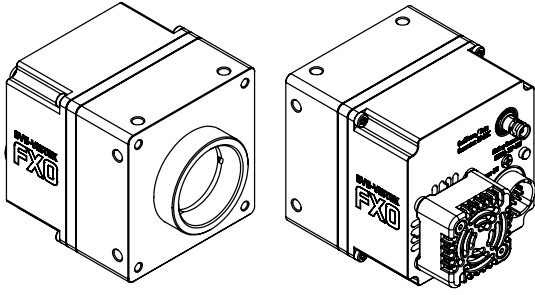

I/O pin assignment

Hirose 12 Pin



1	VIN - (GND)	7	OUT1 (open drain)
2	VIN + (10V to 25V DC)	8	OUT2 (open drain)
3	IN4 (RXD RS232)	9	IN3 + (opto In +)
4	OUT4 (TXD RS232)	10	IN3 - (opto In -)
5	IN1 (0-24V)	11	OUT3 (open drain)
6	IN2 (0-24V)	12	OUT0 (open drain)