



常规

型号:	fxo541CCX
产品代码:	F002087
产品系列:	FXO CoaXPress
状态:	Available

传感器

传感器类型:	Area scan
色度:	Color
光谱:	Visible
光谱范围:	400 nm to 1000 nm
分辨率:	4,480 × 4,504 (20.20 MP)
传感器型号:	Sony IMX541LQA
传感器架构 (材料) :	cmos
快门类型:	global-shutter
传感器尺寸:	12.28 × 12.34 mm (17.41 mm, 17.5mm (Type 1.1))
像素尺寸:	2.74 μm × 2.74 μm

像素格式

传感器位深度:	8-Bit,12-Bit
RGB像素格式:	bayer8, bayer12

成像性能

动态范围:	72 dB
信噪比:	39.8 dB

时序与增益

最大帧率:	35.7
曝光时间:	21 μ s to 60 s
增益:	0.0 dB to 48.0 dB

I/O与电源

非电气隔离IO:	0 x LVDS input, 0 x LVDS output, 0 x TTL input, 0 x TTL output, 2 x 24V input, 4 x Open drain output,
特定非电气隔离IO:	1 x RS232 input, 1 x RS232 output, 0 x RS422 input, 0 x RS422 output,
光电隔离线路:	1 x Optical isolated input, 0 x Optical isolated input,
电源供应:	10 to 25VDC, Power over CoaXPress
功耗:	External: 8 W (typical)

工作条件

工作温度 (外壳):	-10 °C to 65 °C
------------	-----------------

机械特性

机身尺寸 (L x W x H mm) :	70 x 50 x 50
IP防护等级:	IP30
镜头接口:	C-Mount
重量:	240 g

板载内存与FPGA

非易失性存储器 (闪存) :	32 MByte
----------------	----------

接口

数字接口:	cxp-12 with 1 connection
接口连接器:	(micro-BNC)

固件功能 - 图像控制

曝光模式:	Manual, Auto, External
增益模式:	Auto, Manual
白平衡模式:	auto, manual

固件功能 - 图像控制

图像控制功能:

FW Features - Image Control

固件功能 - 相机控制

触发模式/同步:

INTERNAL, SOFTWARE, EXTERNAL

相机控制功能:

PoCxP, User Sets, PWM(4), Sequencer,

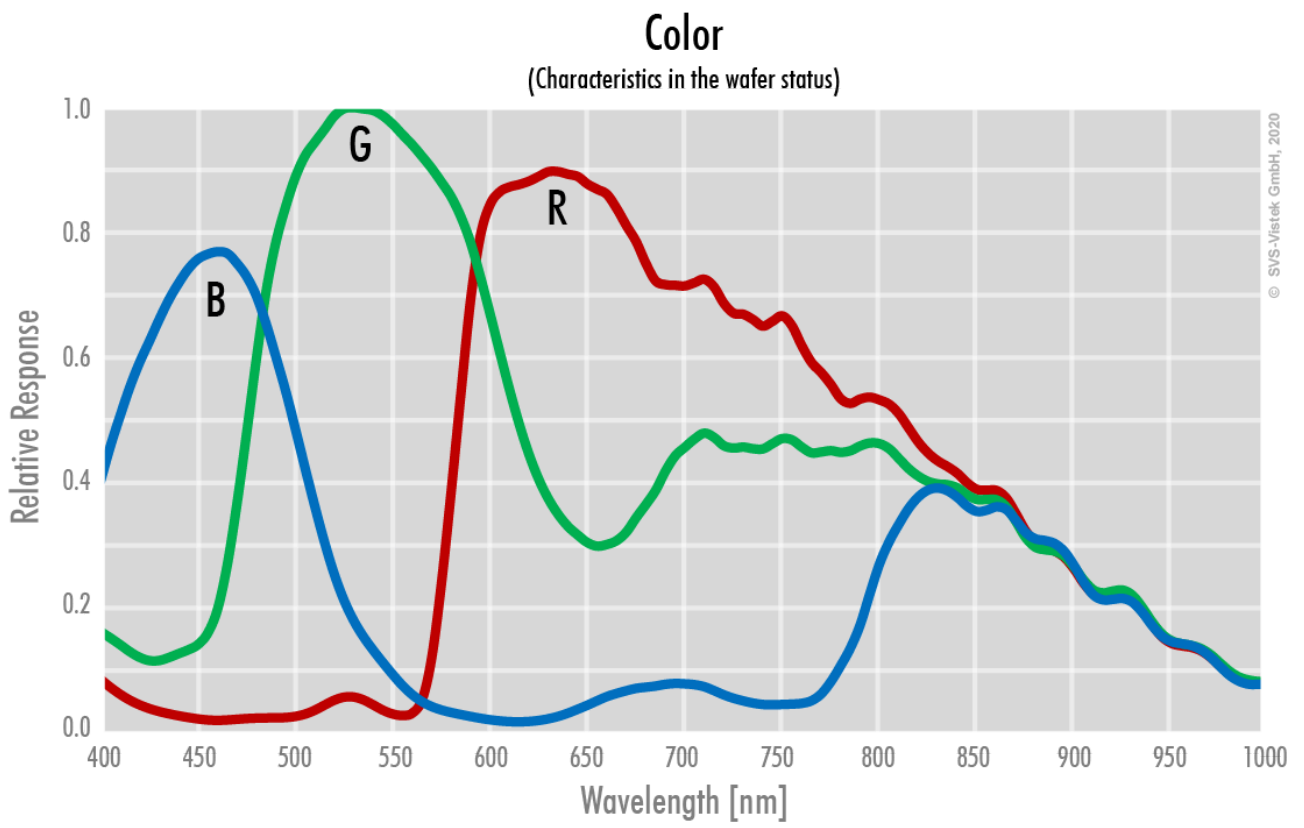

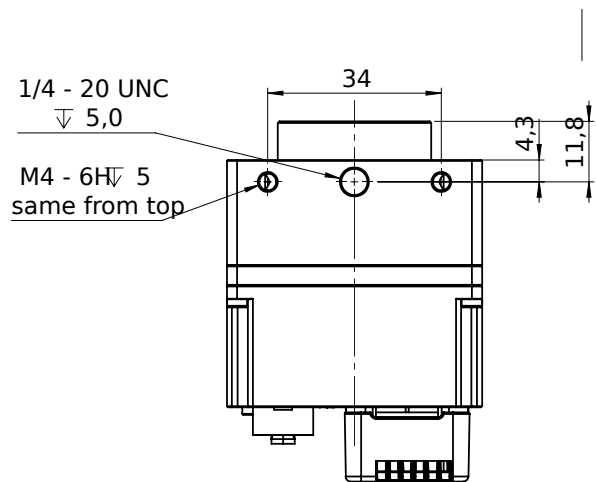
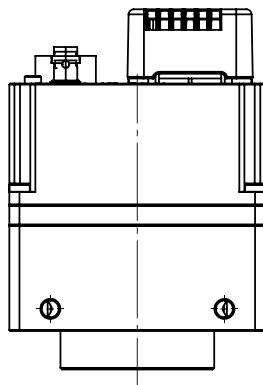
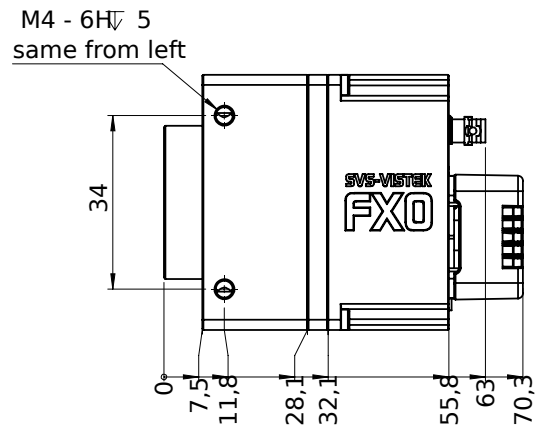
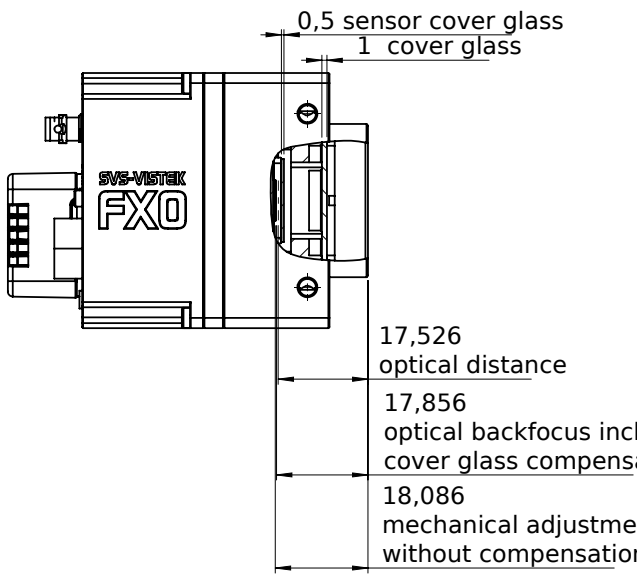
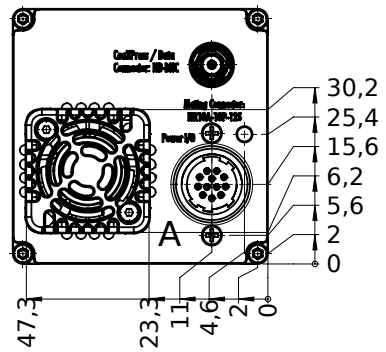
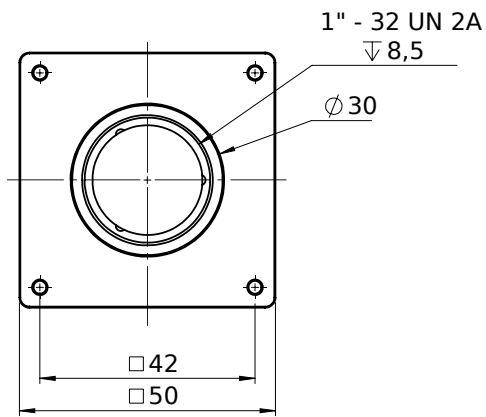

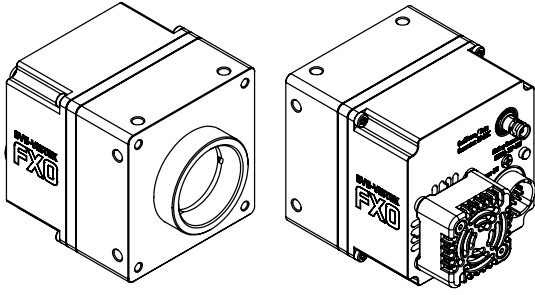

I/O pin assignment

Hirose 12 Pin



1	VIN - (GND)	7	OUT 1 (open drain)
2	VIN + (10 V to 25 V DC)	8	OUT 2 (open drain)
3	IN 4 (RXD RS232)	9	IN 3 + (opto In +)
4	OUT 4 (TXD RS232)	10	IN 3 - (opto In -)
5	IN 1 (0-24V)	11	OUT 3 (open drain)
6	IN 2 (0-24V)	12	OUT 0 (open drain)