



常规

型号:	exo542CGE
产品代码:	F002169
产品系列:	EXO GigE
状态:	Available

传感器

传感器类型:	Area scan
色度:	Color
光谱:	Visible
光谱范围:	400 nm to 1000 nm
分辨率:	5,320 × 3,032 (16.10 MP)
传感器型号:	Sony IMX542LQA
传感器架构 (材料) :	cmos
快门类型:	global-shutter
传感器尺寸:	14.58 × 8.31 mm (16.78 mm, 16.8mm (Type 1.1))
像素尺寸:	2.74 μm × 2.74 μm

像素格式

传感器位深度:	8-Bit,12-Bit,12-Bit
RGB像素格式:	bayer8, bayer12packed

时序与增益

最大帧率:	7
曝光时间:	17 μ s to 60 s
增益:	0.0 dB to 48.0 dB

I/O与电源

非电气隔离IO:	0 x LVDS input, 0 x LVDS output, 0 x TTL input, 0 x TTL output, 2 x 24V input, 4 x Open drain output,
特定非电气隔离IO:	1 x RS232 input, 1 x RS232 output, 0 x RS422 input, 0 x RS422 output,
光电隔离线路:	1 x Optical isolated input, 0 x Optical isolated input,
电源供应:	10 to 25VDC, Power over Ethernet
功耗:	External: 4.5 W (typical)

工作条件

工作温度 (外壳):	-10 °C to 65 °C
------------	-----------------

机械特性

机身尺寸 (L x W x H mm) :	43 x 50 x 50
滤光片/保护玻璃:	IR-Cut 680
IP防护等级:	IP40
镜头接口:	C-Mount
重量:	143 g

板载内存与FPGA

图像缓存 (RAM) :	192 MByte
非易失性存储器 (闪存) :	32 MByte

接口

数字接口:	gige
接口连接器:	(RJ-45)

固件功能 - 图像控制

曝光模式:	Manual, Auto, External
增益模式:	Auto, Manual
白平衡模式:	auto, manual
图像控制功能:	FW Features - Image Control

固件功能 - 相机控制

触发模式/同步:

INTERNAL, SOFTWARE, EXTERNAL

相机控制功能:

PTP, User Sets, POE, PWM(4), Sequencer,

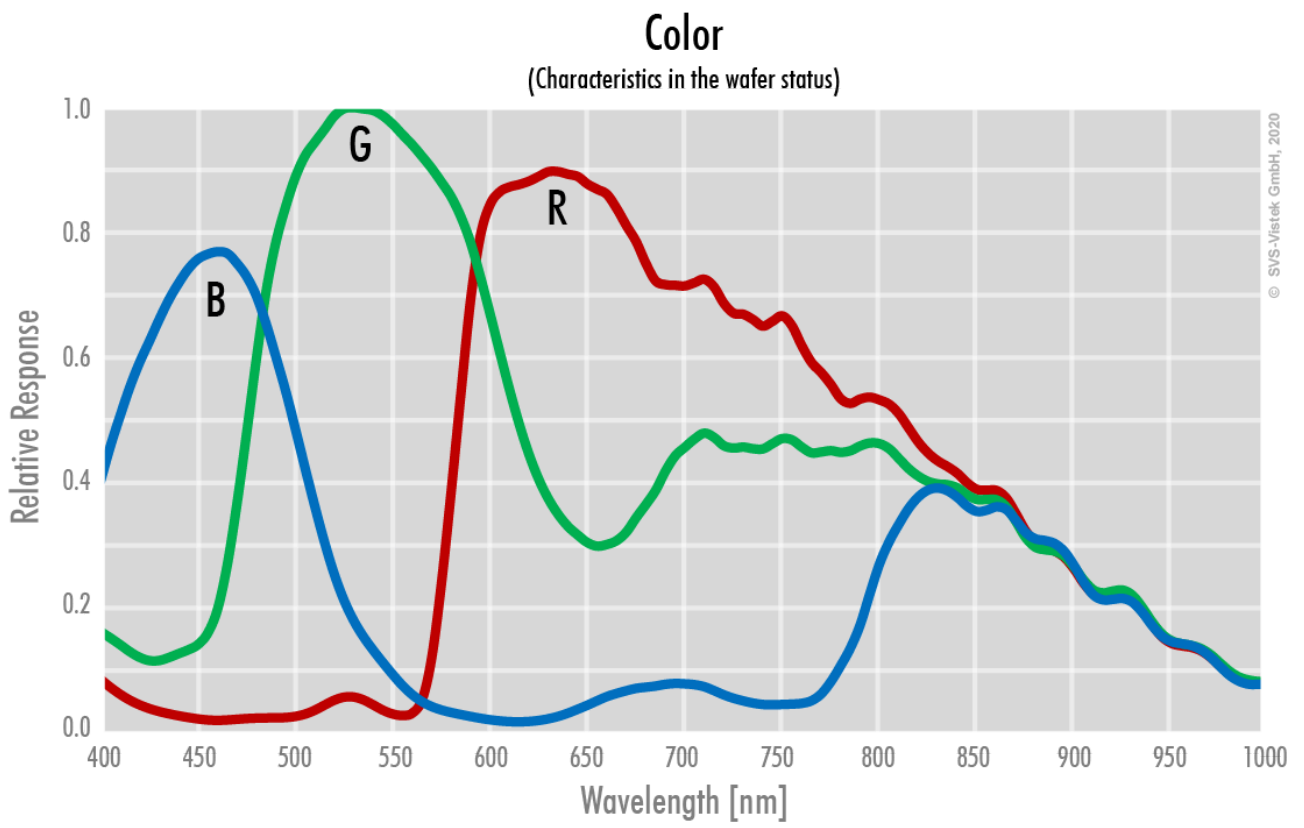

front

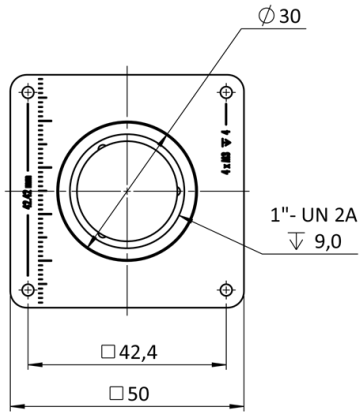

back

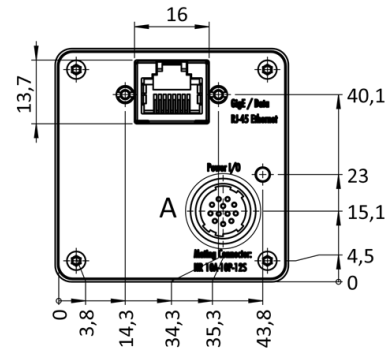

cross section

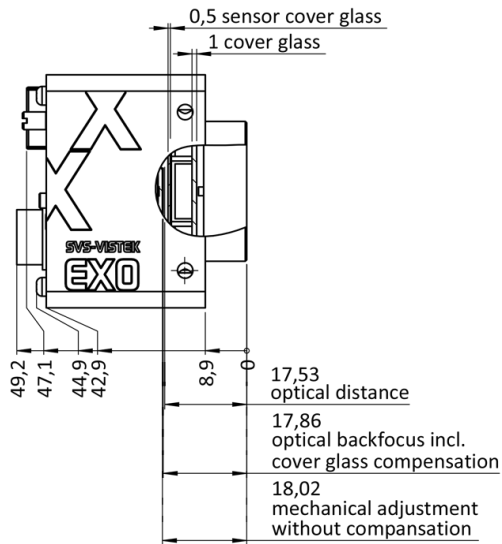

right side

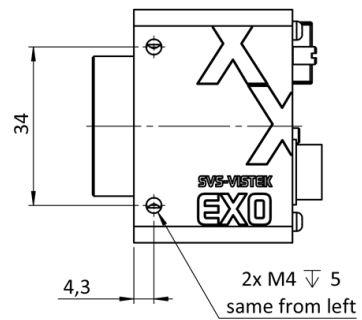

top

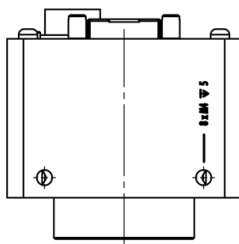

bottom

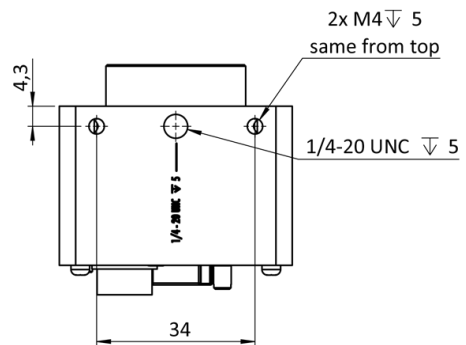

3D

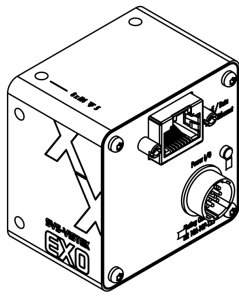
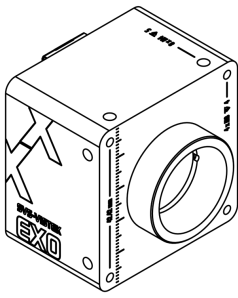

I/O pin assignment

Hirose 12 Pin

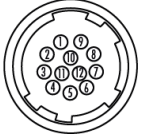

1	VIN -	(GND)	7	OUT 1	(open drain)
2	VIN +	(10 V to 25 V DC)	8	OUT 2	(open drain)
3	IN 4	(RXD RS232)	9	IN 3 +	(opto In +)
4	OUT 4	(TXD RS232)	10	IN 3 -	(opto In -)
5	IN 1	(0-24V)	11	OUT 3	(open drain)
6	IN 2	(0-24V)	12	OUT 0	(open drain)