



常规

型号:	exo265MGE
产品代码:	F002186
产品系列:	EXO GigE
状态:	Available

传感器

传感器类型:	Area scan
色度:	Mono
光谱:	Visible
光谱范围:	400 nm to 1000 nm
分辨率:	2,048 × 1,536 (3.10 MP)
传感器型号:	Sony IMX265LLR
传感器架构 (材料) :	cmos
快门类型:	global-shutter
传感器尺寸:	7.07 × 5.3 mm (8.83 mm, 8.9mm (Type 1/1.8))
像素尺寸:	3.45 μm × 3.45 μm

像素格式

传感器位深度:	8-Bit,12-Bit,12-Bit
单色像素格式:	mono8, mono12packed

成像性能

动态范围: 72 dB

信噪比: 40 dB

时序与增益

最大帧率: 39

最大帧率 (突发) : 56 fps

曝光时间: 24 μ s to 60 s

增益: 0.0 dB to 48.0 dB

I/O与电源

非电气隔离IO: 0 x LVDS input, 0 x LVDS output, 0 x TTL input, 0 x TTL output, 2 x 24V input, 4 x Open drain output,

特定非电气隔离IO: 1 x RS232 input, 1 x RS232 output, 0 x RS422 input, 0 x RS422 output,

光电隔离线路: 1 x Optical isolated input, 0 x Optical isolated input,

电源供应: 10 to 25VDC, Power over Ethernet

功耗: External: 4.5 W (typical)

工作条件

工作温度 (外壳): -10 °C to 60 °C

机械特性

机身尺寸 (L x W x H mm) : 43 x 50 x 50

IP防护等级: IP40

镜头接口: C-Mount

重量: 138 g

板载内存与FPGA

图像缓存 (RAM) : 192 MByte

非易失性存储器 (闪存) : 32 MByte

接口

数字接口: gige

接口连接器: (RJ-45)

固件功能 - 图像控制

曝光模式: Manual, Auto, External

固件功能 - 图像控制

增益模式: Auto, Manual

图像控制功能: FW Features - Image Control

固件功能 - 相机控制

触发模式/同步: INTERNAL, SOFTWARE, EXTERNAL

相机控制功能: PTP, BurstMode, User Sets, POE, PWM(4), Sequencer,

Quantum Efficiency

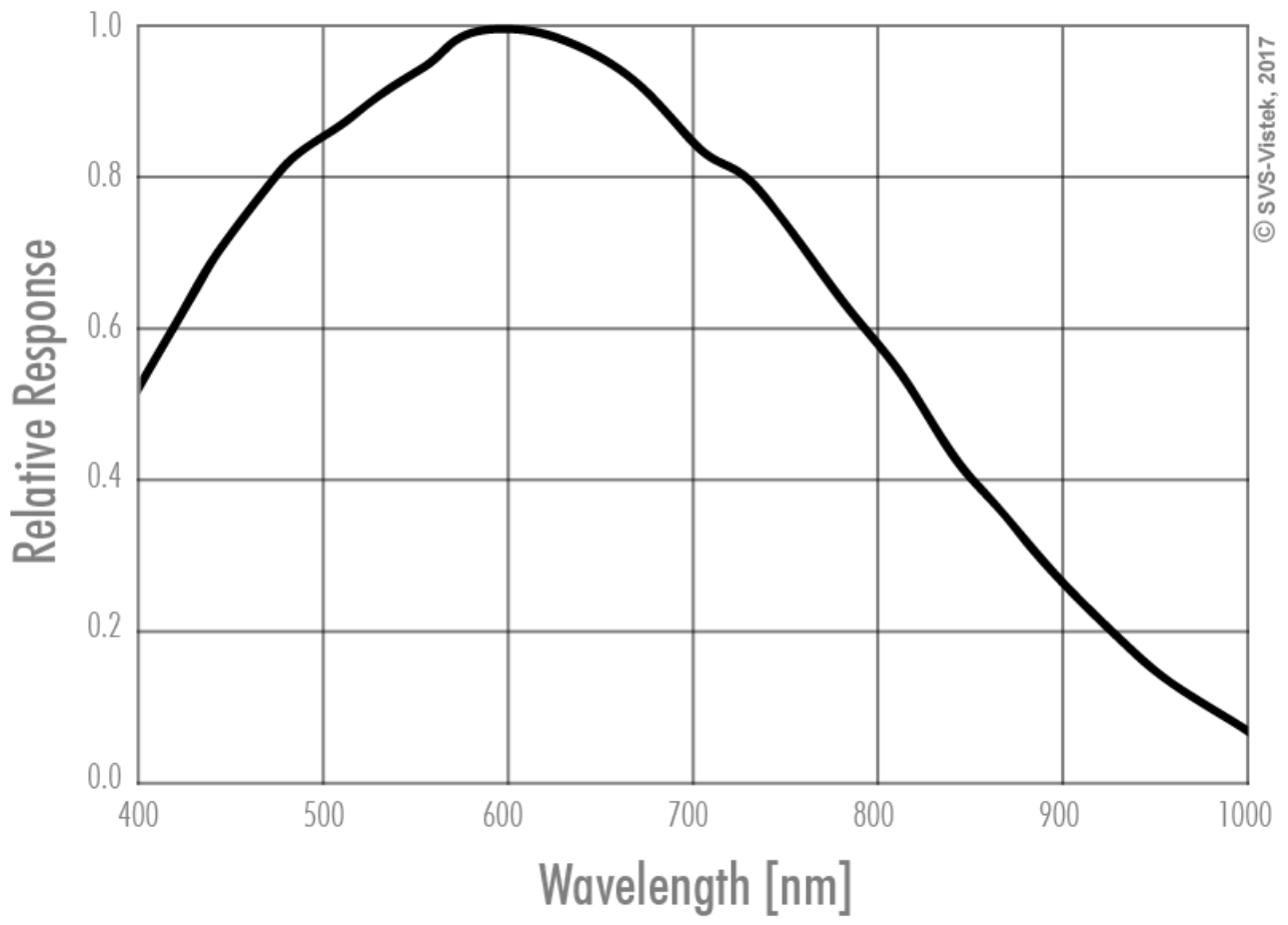

front

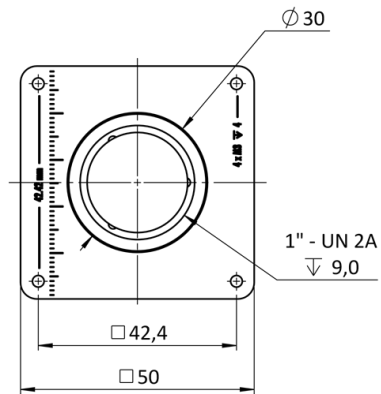

back

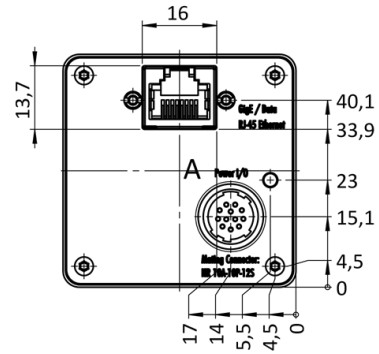

cross section

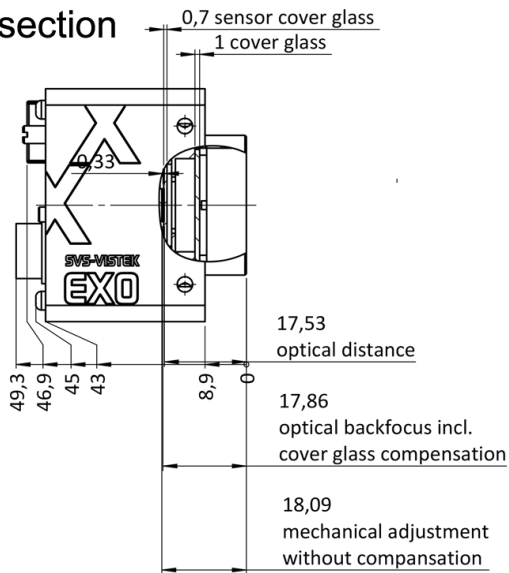

right side

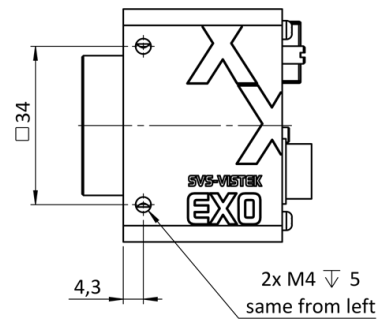

top

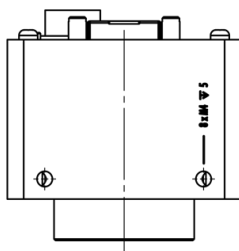

bottom

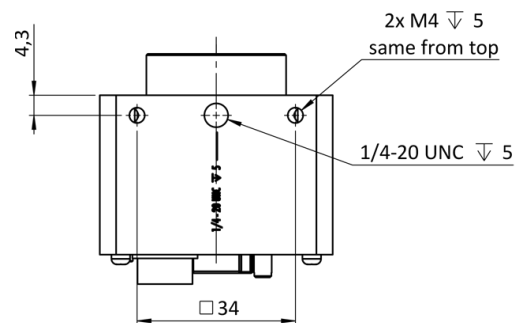

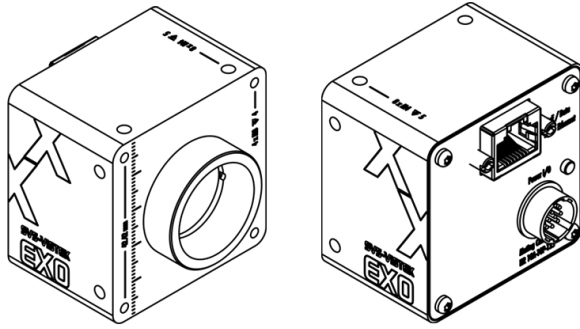

I/O pin assignment



1	VIN - (GND)	7	OUT 1 (open drain)
2	VIN + (10 V to 25 V DC)	8	OUT 2 (open drain)
3	IN 4 (RXD RS232)	9	IN 3 + (opto In +)
4	OUT 4 (TXD RS232)	10	IN 3 - (opto In -)
5	IN 1 (0-24V)	11	OUT 3 (open drain)
6	IN 2 (0-24V)	12	OUT 0 (open drain)