



## 常规

型号:	exo304CGE
产品代码:	F002160
产品系列:	EXO GigE
状态:	Available

## 传感器

传感器类型:	Area scan
色度:	Color
光谱:	Visible
光谱范围:	400 nm to 1000 nm
分辨率:	4,096 × 3,000 (12.30 MP)
传感器型号:	Sony IMX304LQR
传感器架构 (材料) :	cmos
快门类型:	global-shutter
传感器尺寸:	14.13 × 10.35 mm (17.52 mm, 17.6mm (Type 1.1))
像素尺寸:	3.45 μm × 3.45 μm

## 像素格式

传感器位深度:	8-Bit,12-Bit,12-Bit
RGB像素格式:	bayer8, bayer12packed

## 成像性能

动态范围:	72 dB
信噪比:	39.5 dB

## 时序与增益

最大帧率:	10
最大帧率 (突发) :	23.6 fps
曝光时间:	28 $\mu$ s to 60 s
增益:	0.0 dB to 48.0 dB

## I/O与电源

非电气隔离IO:	0 x LVDS input, 0 x LVDS output, 0 x TTL input, 0 x TTL output, 2 x 24V input, 4 x Open drain output,
特定非电气隔离IO:	1 x RS232 input, 1 x RS232 output, 0 x RS422 input, 0 x RS422 output,
光电隔离线路:	1 x Optical isolated input, 0 x Optical isolated input,
电源供应:	10 to 25VDC, Power over Ethernet
功耗:	External: 5 W (typical)

## 工作条件

工作温度 (外壳):	-10 °C to 60 °C
------------	-----------------

## 机械特性

机身尺寸 (L x W x H mm) :	43 x 50 x 50
滤光片/保护玻璃:	IR-Cut - 680nm
IP防护等级:	IP40
镜头接口:	C-Mount
重量:	140 g

## 板载内存与FPGA

图像缓存 (RAM) :	192 MByte
非易失性存储器 (闪存) :	32 MByte

## 接口

数字接口:	gige
接口连接器:	(RJ-45)

## 固件功能 - 图像控制

曝光模式:	Manual, Auto, External
增益模式:	Auto, Manual
白平衡模式:	auto, manual
图像控制功能:	FW Features - Image Control

## 固件功能 - 相机控制

触发模式/同步:	INTERNAL,SOFTWARE,EXTERNAL
相机控制功能:	PTP, BurstMode, User Sets, POE, PWM(4), Sequencer,

# Quantum Efficiency

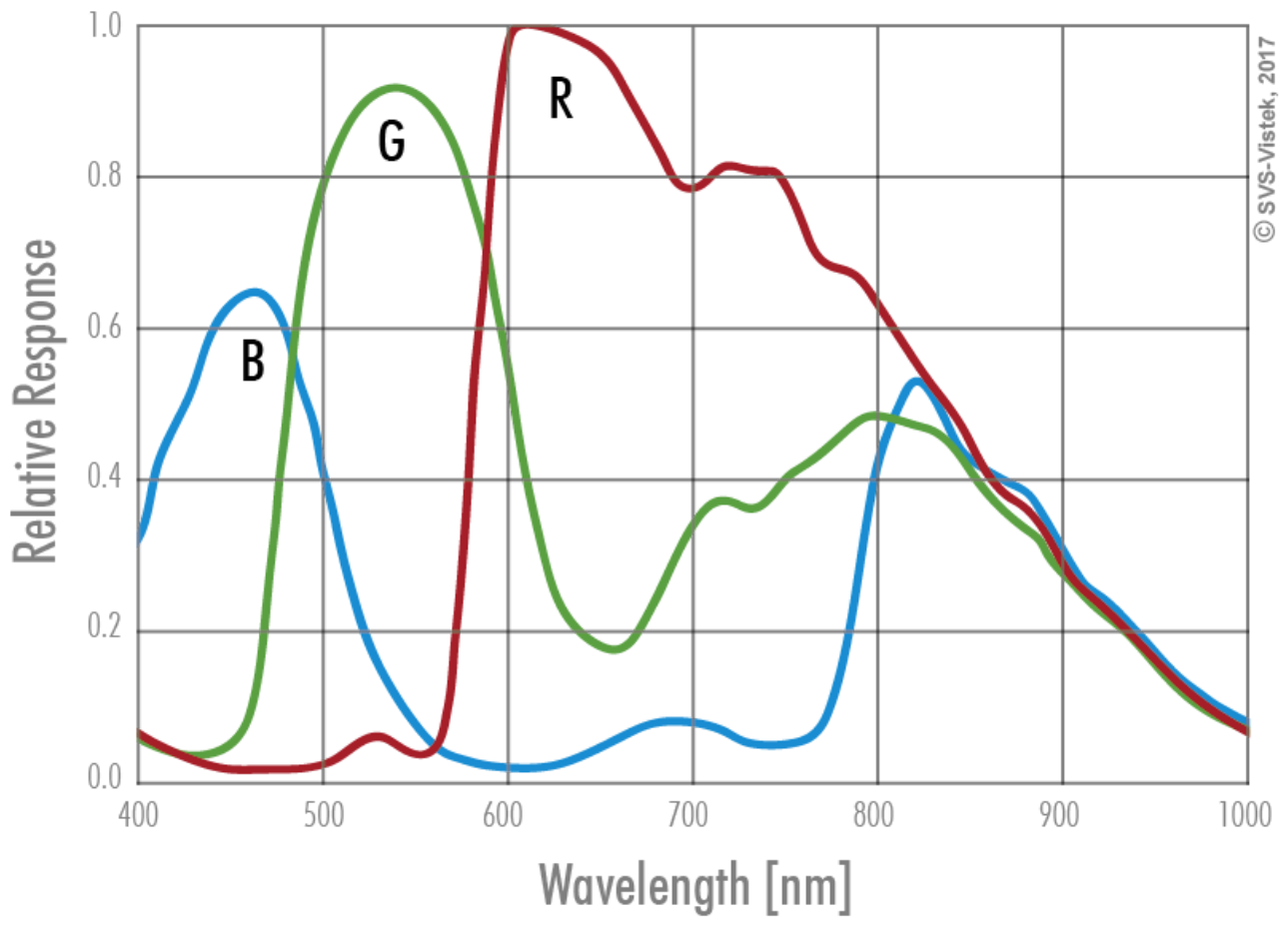

© SVS-Vistek, 2017

front

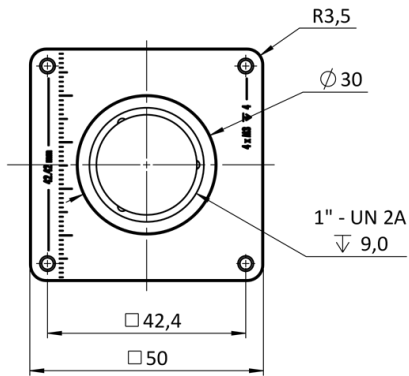

back

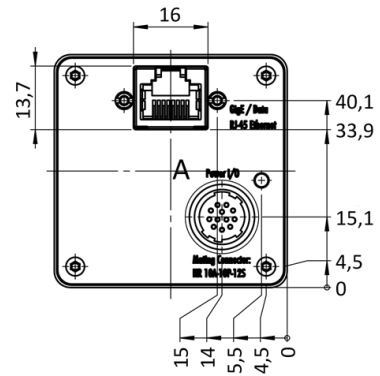

cross section

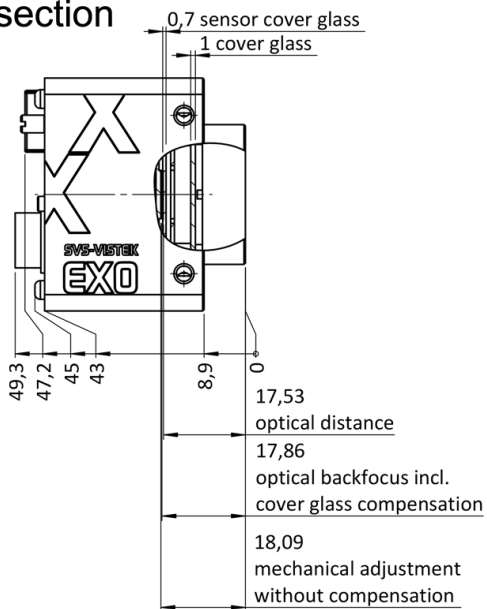

right side

right view

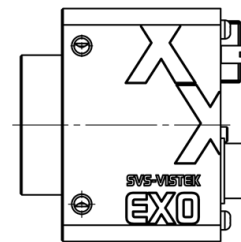

top

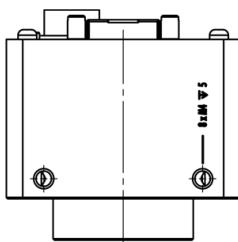

bottom

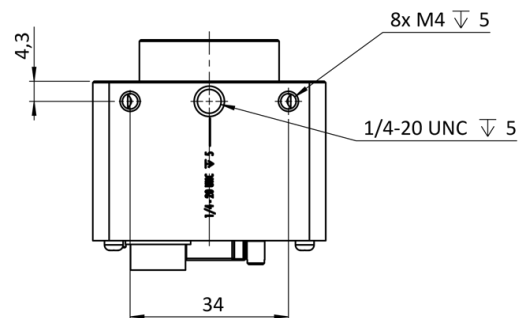

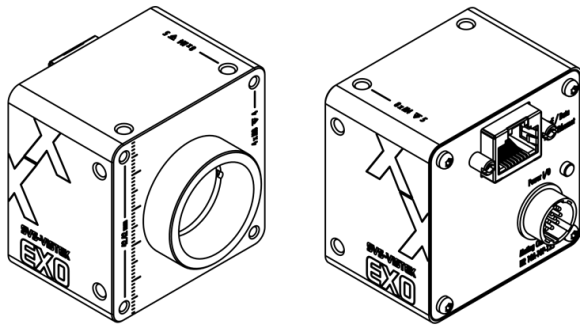

## I/O pin assignment



1	VIN - (GND)	7	OUT 1 (open drain)
2	VIN + (10 V to 25 V DC)	8	OUT 2 (open drain)
3	IN 4 (RXD RS232)	9	IN 3 + (opto In +)
4	OUT 4 (TXD RS232)	10	IN 3 - (opto In -)
5	IN 1 (0-24V)	11	OUT 3 (open drain)
6	IN 2 (0-24V)	12	OUT 0 (open drain)