



MotionBLITZ® EoSens® mini2 Manual

mini2MGE-CM2, mini2MGE-CM2HG, mini2MGE-CM4, mini2MGE-CM4HG,
mini2MGE-FGM2, mini2MGE-FGM2HG, mini2MGE-FGM4, mini2MGE-FGM4HG

Content

General information	7
1.1 Company information	7
1.1.1 Disclaimer	7
1.1.2 Copyright notice	7
1.2 Legal information	8
1.2.1 Registered trademarks	8
1.2.2 Conformity and use	8
1.2.3 Rules and regulations for USA and Canada	9
1.2.4 Rules and regulations for Europe	9
1.2.5 Warranty and non-warranty clause	9
1.3 Supplements	10
1.4 Tips and notes	10
1.5 Support	11
Introduction	12
2.1 Intended use	12
2.2 Scope of delivery	12
2.3 Accessories	13
2.4 System requirements	13
The camera	14
3.1 Camera description	14
3.2 Operating temperature	15
3.3 Cooling	16
3.4 Interfaces of the camera	17
3.4.1 Status LEDs	18
3.4.2 GigE interface	18
Setting up	19
4.1 Connecting the camera	19
4.2 Connecting external signals	20

4.2.1	Connecting the trigger input and SyncIN	20
4.2.2	Sync input timing	21
4.2.3	Sync / ARM output	21
4.2.4	Trigger connection	22
4.2.5	Trigger signal pulse width	23
4.2.6	Trigger signal processing	23
4.2.7	Analog input signal definition	23
4.3	Manually assigning an IP address	23
4.4	Using multiple network cards	25
4.5	Accelerating the network speed	26
4.6	Cleaning sensor and lens	28
4.7	Troubleshooting	29

The MotionBLITZ Director 2 software 31

5.1	Introduction	31
5.1.1	Supported cameras	31
5.1.2	System requirements	31
5.1.3	Installing the software	32
5.2	The user interface	32
5.2.1	Starting the software	32
5.2.2	The user interface	33
5.2.3	Connecting the camera	34
5.3	Settings	34
5.3.1	Overview	34
5.3.2	Camera settings	35
5.3.3	Camera IO	38
5.3.4	Record settings	39
5.3.5	Program settings	43
5.3.6	Advanced settings	46
5.4	Display window	47
5.4.1	Display window icons	47
5.4.2	Gamma correction panel	50
5.4.3	Bayer adjustment (white balance)	51
5.4.4	Open images	53
5.4.5	Image export	54
5.5	Recording	56
5.5.1	Overview	56

5.5.2	Start recording	57
5.5.3	Stop recording	57
5.5.4	Playback	57
5.5.5	Select a sequence	58
5.5.6	Remove a sequence	59
5.5.7	Save a sequence	59
5.5.8	Export directory	60
5.5.9	Available space	61
5.5.10	Export name	61
5.6	Multi-camera mode	62
5.6.1	Overview	62
5.6.2	MultiCam playback	63
5.6.3	Save a MultiCam sequence	63
5.6.4	Open a MultiCam sequence	63
	Technical data	64
6.1	Power connector	64

List of figures

Fig. 3-1:	Camera mounted to a heat sink (example)	16
Fig. 3-2:	Interfaces of the camera MotionBLITZ® EoSens® mini2	17
Fig. 4-1:	Connecting camera and image processing system	19
Fig. 4-2:	Trigger / Sync input signal definition	21
Fig. 4-3:	Sync / ARM output	22
Fig. 4-4:	Trigger connection	22
Fig. 4-5:	Trigger signal pulse width	23
Fig. 5-1:	User interface	33
Fig. 5-2:	Available cameras	34
Fig. 5-3:	Adjusting the ROI	36
Fig. 5-4:	Camera IO	38
Fig. 5-5:	Ring mode	41
Fig. 5-6:	Recording sequences	42
Fig. 5-7:	Multi-sequence recording	43
Fig. 5-8:	Program settings	43
Fig. 5-9:	Advanced settings	46

Fig. 5-10: Display window	48
Fig. 5-11: Adjusting white balance manually	51
Fig. 5-12: Histogram	52
Fig. 5-13: Multiple files side by side	53
Fig. 5-14: Image export dialog	55
Fig. 5-15: Save a sequence	59
Fig. 5-16: Select images	60
Fig. 5-17: MultiCam mode	62
Fig. 6-1: Pinning of matching power plug (solder side)	64

General information

1.1 Company information

Allied Vision Gilching GmbH

Ferdinand-Porsche-Str. 3

82205 Gilching

Germany

Tel.: +49 8105 3987-60

Fax: +49 8105 3987-699

Mail: info@alliedvision.com

Web: www.alliedvision.com

1.1.1 Disclaimer

This manual contains important instructions for safe and efficient handling of our products. This manual is part of the product and must be kept accessible in the immediate vicinity of the product for any person working on or with this product .

Read carefully and make sure you understand this manual prior to starting any work with this product. The basic prerequisite for safe work is compliant with all specified safety and handling instructions.

Accident prevention guidelines and general safety regulations should be applied.

Illustrations in this manual are provided for basic understanding and can vary from the actual model of this product. No claims can be derived from the illustrations in this manual.

The product has been produced with care and has been thoroughly tested. In case of any complaint, contact your local Allied Vision distributor. You will find a list of distributors in your area on [Allied Vision Distributors](#).

1.1.2 Copyright notice

Forwarding and duplicating of this document, as well as using or revealing its contents are prohibited without written approval. All rights reserved with regard to patent claims or submission of design or utility patent.

The specification is subject to change without notice in advance. The brand and product names are trademarks of their respective companies. Any configuration other than original product specification is not guaranteed.

1.2 Legal information

Errors and omissions excepted.

These products are designed for industrial applications only. Cameras from Allied Vision Gilching GmbH are not designed for life support systems where malfunction of the products might result in any risk of personal harm or injury. Customers, integrators and end users of Allied Vision Gilching GmbH products might sell these products and agree to do so at their own risk, as Allied Vision Gilching GmbH will not take any liability for any damage from improper use or sale.

1.2.1 Registered trademarks

In this manual the following registered trademarks may be used:

- ImageBLITZ®
- EoSens®
- GenICam®
- Microsoft® and Windows®
- Intel®

Throughout the manual, these trademarks are not specifically marked as registered trademarks. This in no way implies that these trademarks can be used in another context without the trademark sign.

1.2.2 Conformity and use

This equipment has been tested and found to comply with the limits for a Class A digital device, pursuant to Part 15 of the FCC Rules. These requirements are designed to provide reasonable protection against harmful interference when the equipment is operated in a commercial environment.

This equipment generates, uses, and can radiate radio frequency energy and, if not installed and used in accordance with the instructions given in this guide, may cause harmful interference to radio communications. Operation of this equipment in a residential area is likely to cause harmful interference in which case the user will have to correct the interference at its own expense.

You are herewith cautioned that any changes or modifications not expressly approved in this description could void your authority to operate this equipment.

1.2.3 Rules and regulations for USA and Canada

This device complies with part 15 of the FCC Rules. Operation is subject to the following conditions: (1) This device may not cause harmful interference, and (2) this device must accept any interference received, including interference that may cause undesired operation.

This equipment is compliant with Class A of CISPR 32. In a residential environment this equipment may cause radio interference.

This equipment has been tested and found to comply with the limits for a Class A digital device, pursuant to part 15 of the FCC rules.

It is necessary to use a shielded power supply cable. You can then use the "shield contact" on the connector which has GND contact to the device housing. This is essential for any use. If not done and the device is destroyed due to Radio Magnetic Interference (RMI) WARRANTY is void!

- Power: US/UK and European line adapter can be delivered. Otherwise use filtered and stabilized DC power supply.
- Shock & vibration resistance is tested. For detailed specifications refer to the section on specifications.

1.2.4 Rules and regulations for Europe

This device is CE tested, the following rules apply:

- EN 55032:2015
- EN 61000-6-2:2019

The product is in compliance with the requirements of the following European directives:

- 2011/65/EU
- 2015/863/EU

All products of Allied Vision Gilching GmbH comply with the recommendation of the European Union concerning RoHS rules.

1.2.5 Warranty and non-warranty clause

The camera does not contain serviceable parts. Do not open the body of the camera. If the camera has been opened, the warranty will be void.

The camera has to be used with a supply voltage according to the camera's specification. Connecting a lower or higher supply voltage, AC voltage, reversal polarity or using wrong pins of the power connector may damage the camera. Doing so will void warranty.

Our warranty does not protect against accidental damage, loss, or acts of nature.

Allied Vision Gilching GmbH cannot be held responsible for the loss of data. We recommend a backup plan.

1.3 Supplements

FOR CUSTOMERS IN CANADA

This apparatus complies with the Class A limits for radio noise emissions set out in Radio Interference Regulations.

POUR LES UTILISATEURS AU CANADA

Cet appareil est conforme aux normes Classe A pour bruits radioélectriques, spécifiées dans le Règlement sur le brouillage radioélectrique.

LIFE SUPPORT APPLICATIONS

The products described in this manual are not designed for use in life support appliances or devices and systems where malfunction of these products can reasonably be expected to result in personal injury.

Allied Vision Gilching GmbH customers using or selling these products for use in such applications do so at their own risk and agree to fully indemnify Allied Vision Gilching GmbH for any damages resulting from such improper use or sale.

1.4 Tips and notes

This manual contains notes that help to avoid data loss or camera damage, and tips that provide information to improve handling the camera. They are marked as follows:

TIPS

Provides information that may help to improve camera handling or avoid data loss.

NOTES

Provides information to avoid damage to the system.

1.5 Support

In case of issues with the camera we are happy to help. For being able to help you in a fast and efficient way, we ask you for a description of the issues using camera in your support request.

- Put your support request to us via the support form: [Support & Repair \(RMA\)](#)
- Fill the form with information about the camera model, the frame grabber model, and operating system. Our support team will come back to you.

Introduction

2.1 Intended use

The camera MotionBLITZ® EoSens® mini2 belongs to the product class of so-called recording cameras that can be used for a variety of purposes.

Recording cameras are designed to capture and record fast movement, processes or short events and replay at slower speed, for example for slow-motion replay of movements in sports, during manufacturing processes, or for scientific research.

OTHER USES

Any other use is regarded as unintended use and leads to the loss of guarantee and liabilities. Contact the manufacturer for other uses.

These products are designed for industrial applications only. **The cameras are not designed for life support systems where malfunction of the products might result in any risk of personal harm or injury.**

2.2 Scope of delivery

The following components are part of delivery. Before installing the camera, check if the delivery is complete:

- MotionBLITZ® EoSens® mini2 camera as ordered
- Shielded Gigabit Ethernet cable
- USB storage device with MotionBLITZ® Director2 software and documentation
- Lens as ordered

2.3 Accessories

OPTIONAL

- BNC break out cable; part no.: KKRKAVERTMC137X or with the right-angle plug KKRKAVERTMC137XW
- Hand trigger cable; part no.: KKRTMBC05L (5 m) or KKRTMBC10L (10 m)

REQUIRED ADDITIONALLY

- Power supply MIK-NTCAM137XL1.5, Lemos 6-pin plug, 12 V DC / 3.5 A output, 1.5 m cable

2.4 System requirements

The PC or image processing system that is connected with the camera must be equipped with:

- Windows 7/8/10 (or higher) operating system
- 1 Gbit Ethernet controller 100/1000 BaseT to control the camera
- To reach high data transfer rates via Ethernet, your Ethernet controller should support jumbo frames that can carry up more than 8000 Bytes of payload.
- Either MotionBLITZ® Director2 software or a GenICAM SDK

MotionBLITZ® EoSens® mini2 cameras can easily be parametrized and controlled by MotionBLITZ® Director2 software. For information on the software, refer to the MotionBLITZ® Director2 software guide.

The camera

3.1 Camera description

MotionBLITZ® EoSens® mini2 high-speed recording cameras were developed to record the fastest processes in extremely confined spaces. Due to its minute dimensions, the MotionBLITZ® EoSens® mini2 can be used flexibly.

Relying on the internal memory, the use of the high-speed recording camera is possible without connection to a PC. 6.5 seconds at full resolution and speed can be recorded without being dependent on an extensive experimental set-up. With its high recording speed, the MotionBLITZ® EoSens® mini2 guarantees a reliable control of even the fastest processes.

Due to its outstanding picture quality, sharp and crystal clear pictures with rich details can be recorded. Even if only confined space is available for the installation of strong lighting sources, there is an adequate solution. The extremely high photo sensitivity facilitates the use of the MotionBLITZ® EoSens® mini2, even under extremely demanding lighting conditions.

The camera MotionBLITZ® EoSens® mini2 is available in monochrome and color. Initially, frames are stored in the internal frame memory of the camera.

The color and monochrome cameras are supplied with the following features:

- Analog / Digital gain
- Autosave mode
- Defective pixel correction
- ImageBLITZ
- Image information field
- Multi-sequence mode
- Record until end
- Ring mode

BAYER FILTER

The sensor of the MotionBLITZ® EoSens® mini2 colour cameras is supplied with a Bayer colour filter. In order to get the colour information, the imaging software has to decode the information of each pixel into red, green, and blue

(RGB) by using the values of its neighbouring pixels. Each red, green and blue filter element covers exactly one pixel on the sensor. A matrix of 2 x 2 filter elements builds a filter element matrix. A Bayer pattern image therefore must have an even number of pixels and an even number of lines.

IDENTIFICATION PLATE

The identification plate at the back of the camera shows the following information:

- Camera name
- MAC No. - the unique hardware address of the network adapter. This address will be used as identifier in networks.
- Serial number
- Voltage: allowed voltage DC 10.5 – 30 V
- Invisible optional features are listed under options with the following abbreviations:

Abbreviation	Meaning
C	Color
FM	F-mount
IB	ImageBLITZ option
M	Memory upgrade
MS	Multi sequence mode
HG	HiG shock-proofed
PR	Power on recording

3.2 Operating temperature

Despite of its high performance, the fanless mini2 camera is compact and works silently. If the camera is mounted on mechanical parts, the heat generated during operation will be dissipated by the cooling fins at the rear of the camera and the mechanical parts.

The camera body temperature must not exceed the values specified in the technical data (see ["Technical data" on page 64](#)).

In case of overheating, the camera will automatically be switched off and the communication between camera and PC will be interrupted.

Durability of the camera will be reduced when being operated in an environment that is constantly exceeding the maximum permissible operating temperature. In this case, take additional cooling measures as described below.

The camera is not intended for use on an isolated mounting plate or in a closed housing because the temperature of the camera will rise continuously.

3.3 Cooling

During operation, the heat from the camera's sensor dissipates to the housing. To maintain reliable performance, it is crucial to adhere to the operating temperature range specified in the camera's technical data.

- Install the camera so that the housing openings at the back or at the sides are not blocked and ventilation is possible under all operating conditions.
- Check the unhindered air flow after installation of surrounding components such as cables.

ADDITIONAL COOLING

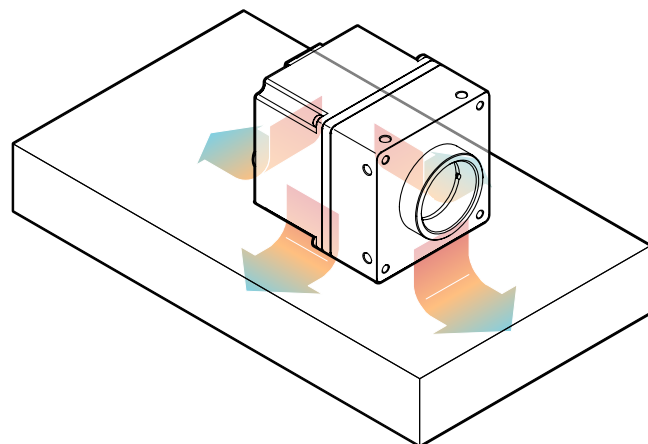

Fig. 3-1: Camera mounted to a heat sink (example)

If the temperature consistently exceeds the maximum operating temperature specified for the camera, additional cooling measures are necessary. This can be achieved by:

- Mounting the camera housing to a heat sink or other heat-dissipating material. For optimal cooling efficiency, ensure that the contact area between the camera housing and the cooling material is as large as possible, allowing for better heat transfer.
In addition, vibrations will be minimized within the entire system.
- If available, activating the built-in fan or adjust the fan control threshold.
- If available, activating the built-in thermoelectric cooling feature.
- Using an air- or water-cooling system.

Even if the housing temperature remains below the maximum operating temperature, using additional cooling is recommended to ensure optimal image quality and power efficiency.

3.4 Interfaces of the camera

The connectors, buttons, and the LED lights are situated at the back of the camera.

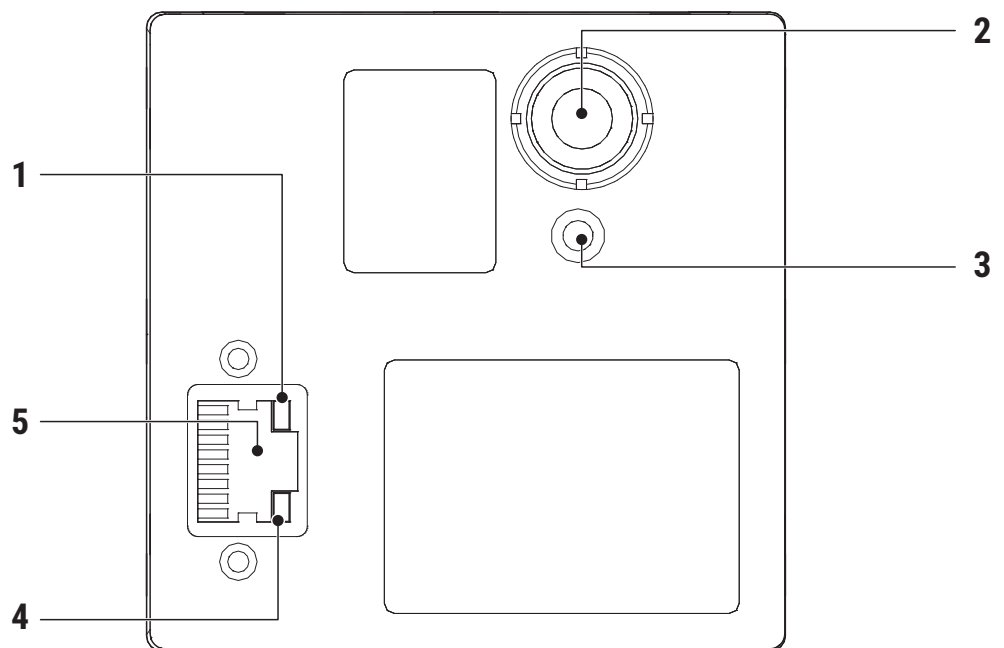

Fig. 3-2: Interfaces of the camera MotionBLITZ® EoSens® mini2

1	Data transfer LED	2	Power connector
3	LED power status	4	1 Gbit transfer LED
5	GigE Vision Interface 100/1000BaseT		

POWER CONNECTOR

The power connector of the camera can either be used to connect a power supply unit directly or via a BNC break-out cable. The BNC break-out cable provides the power and additionally three BNC connectors: trigger IN, sync IN and strobe OUT to connect external signals.

3.4.1

Status LEDs

The multicolor status LED indicates camera and connection states.

POWER LED

Color	LED status	Operating status
RED	Solid	Boot failure (switch off the camera and restart)
ORANGE	After power on for 3 sec	Powering-up in progress
GREEN	Solid	Ready for the first recording after power-up
ORANGE	Toggling	Circular recording in progress, waiting for stop
ORANGE	Solid	Circular recording stopped, waiting for next start

3.4.2

GigE interface

We recommend to use the setting "Jumbo Packet" (see ["Accelerating the network speed" on page 26](#)).

The GigE interface can be used to transfer data from the camera to an image processing system (e.g. a PC) or to control the camera (e.g. starting or stopping a recording).

When downloading frames from the camera to a PC or image processing system, up to 85 MB/s can be transferred.

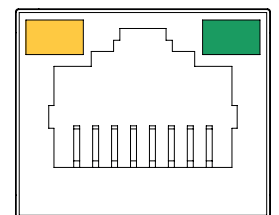

The data transfer status is indicated by the data transfer LEDs:

LED Color	Data transfer
orange	Data transfer in progress
green	Data transfer at 1 Gbit/s

Setting up

4.1 Connecting the camera

The camera must only be connected to non-PoE network cards. Connecting a PoE network card damages the camera board.

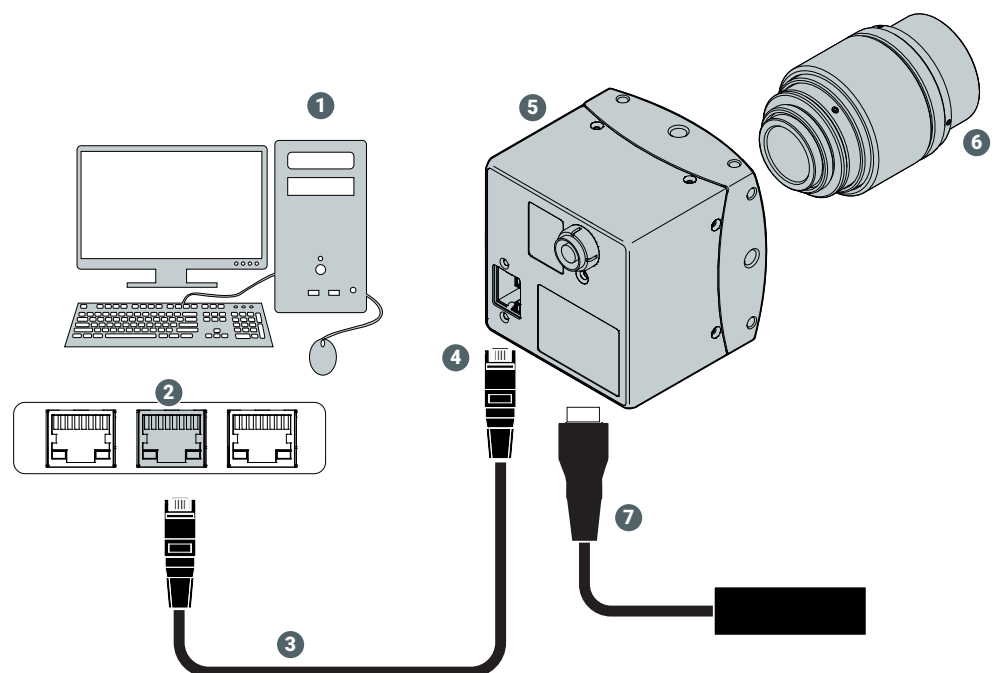

Fig. 4-1: Connecting camera and image processing system

1. Make sure that your network card (2) has been installed properly on the PC (1, see the manual of the network card).
2. Unscrew the dust protection cover of the camera (5).
3. Mount the lens (6).
4. Connect the power supply (7) with the camera.
5. Connect the power supply with the main supply. The status LED of the camera turns orange and changes to green after a few seconds.

Connect only the power supply provided or a power supply with exactly the same technical data and pinning. Connecting a wrong power supply can damage the camera!

6. Connect the shielded Gigabit Ethernet cable (3) with the camera (5).
7. Connect the Gigabit Ethernet cable (3) with the network card (2) of the PC (2). The data transfer status is indicated by the Ethernet status LED.

LED color	Data transfer
Orange	Data transfer in progress
Green	Data transfer at 1 Gb/s

An IP address will be assigned automatically. This may take a few minutes. To accelerate this process or to assign an IP address, see ["Manually assigning an IP address" on page 23](#).

4.2 Connecting external signals

When applying external signals, e.g. to trigger events or synchronize one or more cameras it is important to know the internal circuits of the cameras.

4.2.1 Connecting the trigger input and SyncIN

The trigger connector of the camera provides a trigger input and a SyncIN. Both are isolated from the rest of the circuit by an optocoupler. The pull-up resistors R33 / R32 are powered by an internal DC / DC converter (X3.3 V). The optocoupler will switch as soon as the input is connected to the optocoupler GND (pin 1) of the trigger connector (see ["Trigger connector"](#)).

- A rising edge on the SyncIN input will output the next image if the polarity of the SyncIN has been set to rising edge in the menu "Camera IO" of Director2.
- A rising edge on the trigger input will stop recording in ring mode if the polarity of the trigger has been set to rising edge in the menu "Camera IO" of Director2.

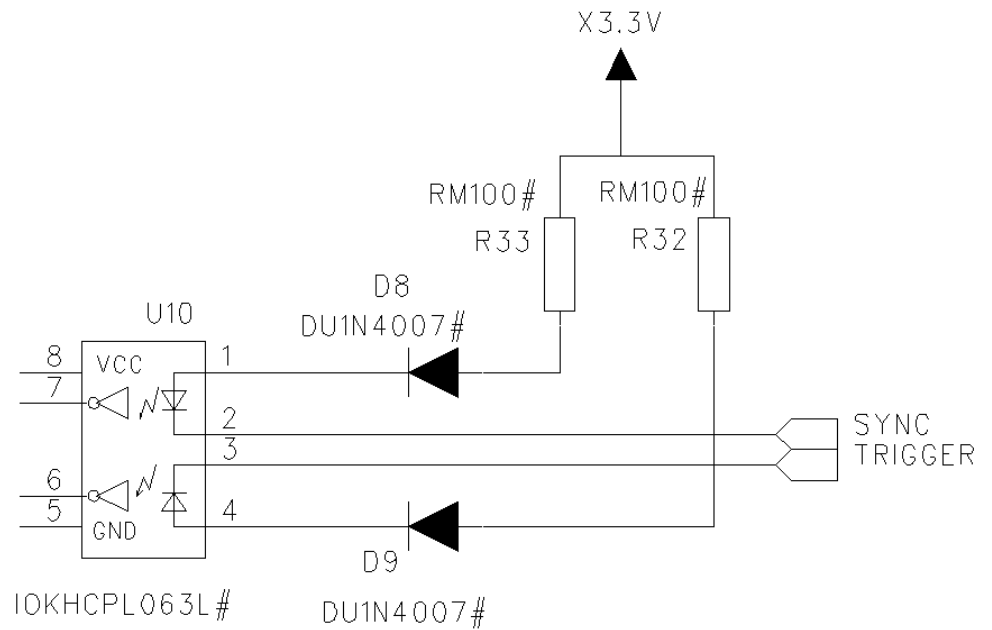

Fig. 4-2: Trigger / Sync input signal definition

The minimum diode current for an active signal is 5 mA.

When using photo electronic sensors for triggering, the maximal voltage drop in connected through status must not exceed 0.2 V.

1. Connect the sensor ground connection with the camera optocoupler ground connection.
2. Connect the sensor (load) output connection with the camera trigger input connection.

4.2.2 Sync input timing

1. In the Camera IO menu, select a rising or a falling edge as active edge. The frequency of the external signal has to be lower than the selected frame rate of the camera.

4.2.3 Sync / ARM output

According to the settings in the menu "Camera IO" of Director2, this pin will either output a Sync or an ARM signal. If SyncOUT is selected, this output will carry a strobe that corresponds to the selected exposure time of the camera. If ARM is selected, it will be active when the camera runs in ring mode and is recording.

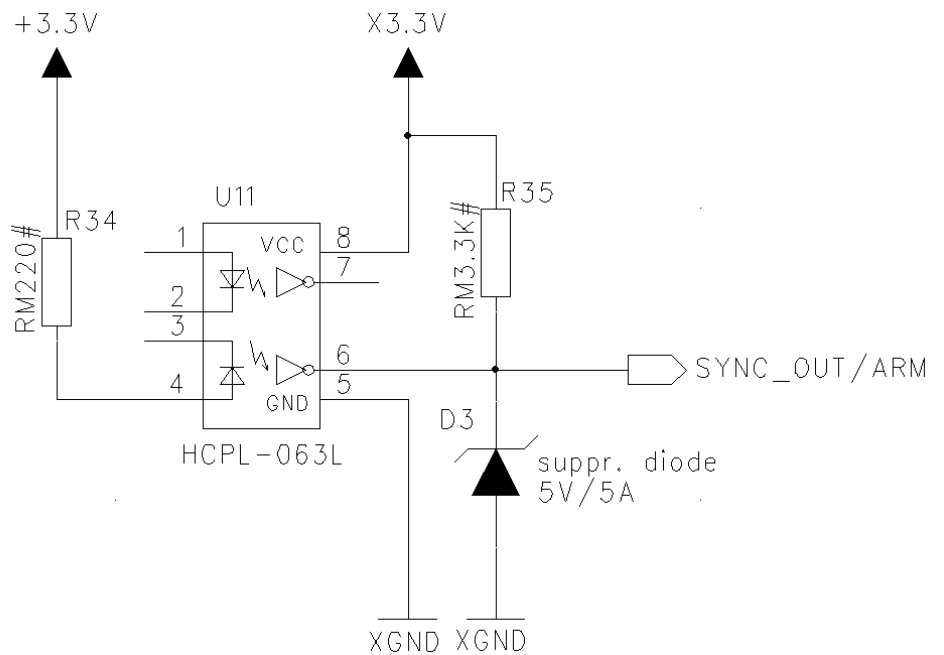

Fig. 4-3: Sync / ARM output

The optocoupler output will sink 13 mA with max. 0.6 V output voltage. The output polarity is positive if the selected signal is active. The suppressor diode protects the output against reverse voltages. It starts conducting if the voltage on the output pin is greater 6 V.

4.2.4

Trigger connection

1. Connect the TriggerIN (digital 4) pin of the trigger connector with the external trigger.
2. Enable External Trigger in the menu "Camera IO" of the software Director2 and decide whether a rising or a falling edge of the signal will stop recording. Recording can either be stopped by a trigger switch or by a low or high external signal.

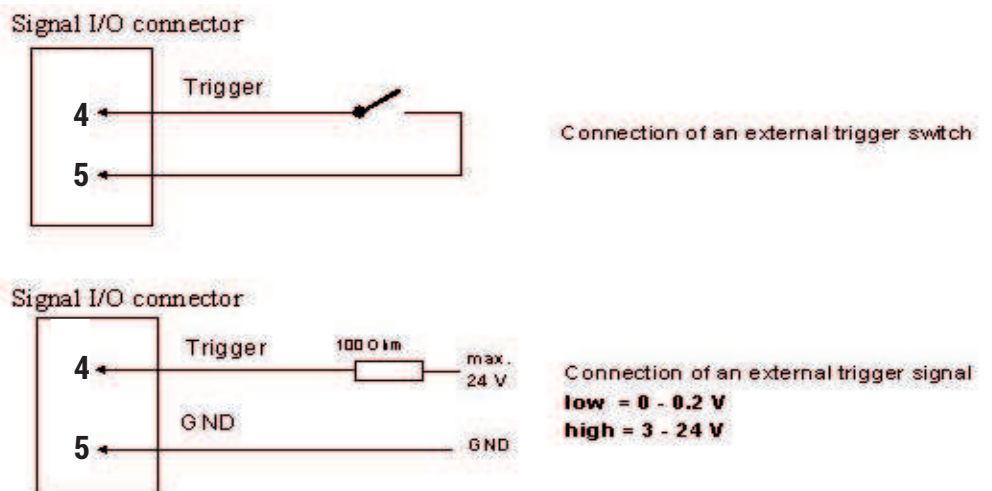

Fig. 4-4: Trigger connection

4.2.5 Trigger signal pulse width

The trigger signal is debounced. Therefore an external mechanical switch can be used. Minimum pulse width according to the camera model is given in the following table.

Trigger polarity	Shape	MotionBLITZ EoSens
Rising		100 ns
		5 ms
Falling		5 ms
		5 μs

Fig. 4-5: Trigger signal pulse width

4.2.6 Trigger signal processing

5 Microseconds after the end of the exposure time (falling edge of camera's strobe signal) the trigger input will be processed. If a trigger becomes active after this point of time, the next frame will be the trigger frame, otherwise (the trigger becomes active before this point of time) the most recently exposed frame will be the trigger frame.

4.2.7 Analog input signal definition

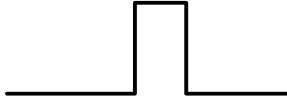
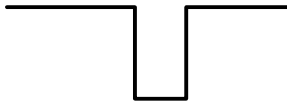
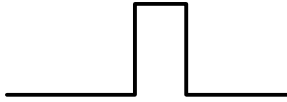
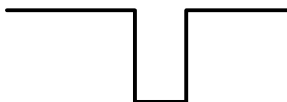
The analog input is protected by a 330 kΩ series resistor and adjusted to deliver the digital value of 255 for 2.55 V input voltage.

4.3 Manually assigning an IP address

The image processing system (e.g. PC) communicates with the camera via Ethernet. Therefore, an appropriate IP address must be assigned to the network card.

In most cases, the IP address will be assigned automatically after connecting a camera. This may take some time.

To accelerate this process, or to assign a fixed IP address, proceed as described below.

To make changes to the settings, administrator rights on the PC are required.

1. Connect the camera via Gigabit Ethernet with the image processing system.
2. Open the *Control Panel Items* in Windows.
3. Open *Network and Sharing Center*.
4. Open *LAN connection*.

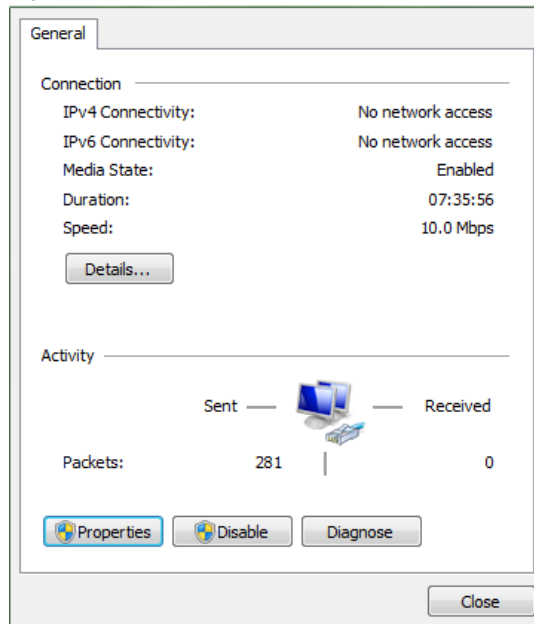

5. Select **Properties**.

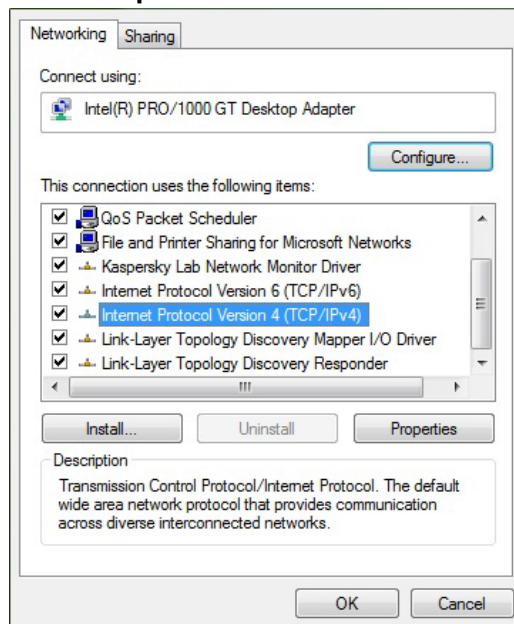

6. Check if Internet Protocol Version 4 (PCT / IPv4) is enabled.

7. Select **Properties**.

General

You can get IP settings assigned automatically if your network supports this capability. Otherwise, you need to ask your network administrator for the appropriate IP settings.

Obtain an IP address automatically

Use the following IP address:

IP address:

Subnet mask:

Default gateway:

Obtain DNS server address automatically

Use the following DNS server addresses:

Preferred DNS server:

Alternate DNS server:

Validate settings upon exit

Advanced...

OK Cancel

8. Assign a valid IP address that is currently not in use, e.g. "192.168.110.1", subnet-mask: "255.255.255.0".

9. Click **OK**.

4.4 Using multiple network cards

When using multiple network cards, it is necessary to assign an IP address to each. Proceed for each card as described below and make sure that the subnet of the two differs.

If for example the IP address "169.122.77.22" is assigned to the first network controller, the IP address of the second controller has to differ in at least one address part above the 255 in the subnet mask.

EXAMPLE

In the example below the subnet mask includes twice the number 255. The IP address of the second card has therefore either to differ in the first or the second three digits, e.g. "169.121.77.22".

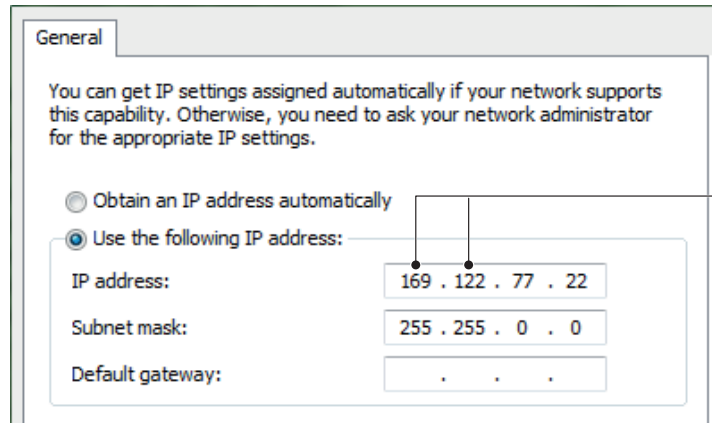

At least one of these triplets in the IP address must be different to the IP address of the network card

4.5 Accelerating the network speed

If the network speed is not fast enough, you should set it to 1000 MB/s Full Duplex.

A fast hard disk in combination with a 1 Gbit Ethernet card allows the use of Jumbo Packet which is faster than full duplex mode.

To make changes to the settings, administrator rights on the PC are required.

1. Open *Network and Sharing Center* in the Windows Control panel.
2. Select *LAN connection*.

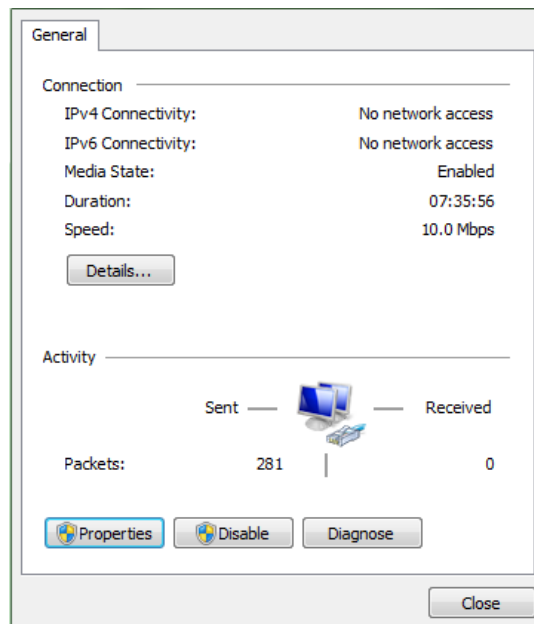

3. Select **Properties**.

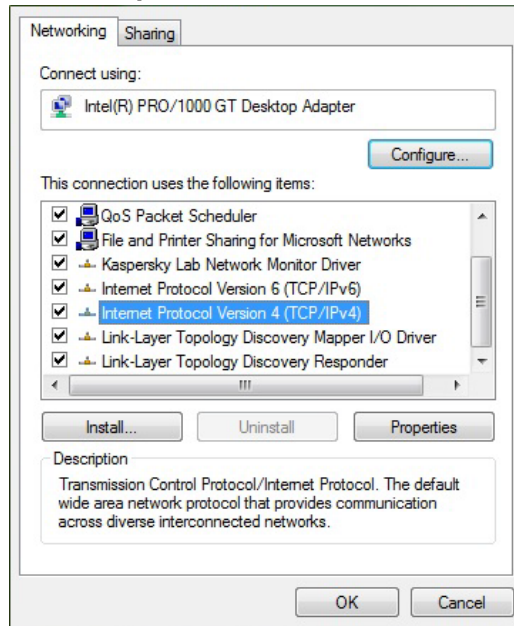

4. Select **Configure**.

5. Open the tab **Advanced**.

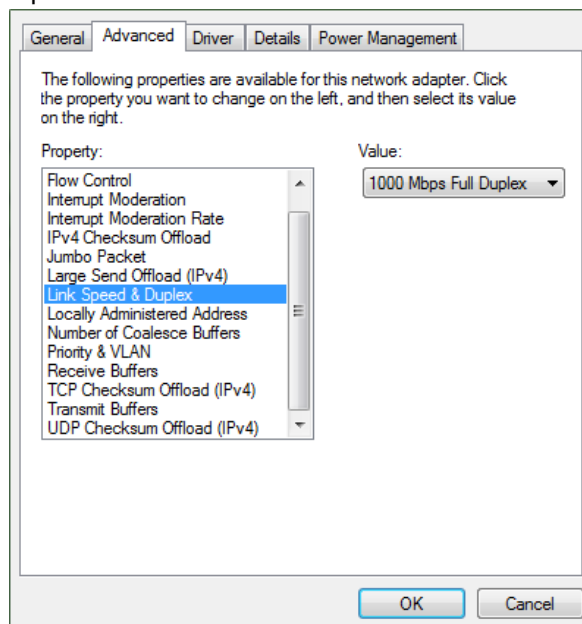

6. Select *Jumbo Packet*. If *Jumbo Packet* is not available, select *Link Speed & Duplex* and set the value to "1000 MB/s Full Duplex".

7. Click **OK**.

4.6

Cleaning sensor and lens

1. If there are coarse particles on the lens or the window of the sensor, use a vacuum cleaner to remove them before cleaning to prevent scratches.
2. Clean the window of the sensor and the lens with a dry and soft lens-cleaning tissue.

Do not use tools that may harm the sensor or lens.

4.7

Troubleshooting

Software does not start	Check whether all the software prerequisites have been installed.
No cameras detected after clicking Connect and / or Error: timeout	<ul style="list-style-type: none">• Check whether camera and PC are connected.• Check the Camera LED status as described in the reference guide of your camera.• Check if an IP address has been assigned to the network card.• Check if the windows firewall allows MotionBLITZ Director2 to work. If the firewall is active, disable the firewall, close MotionBLITZ Director2 and restart the software. If it works, configure MotionBLITZ Director2 in the firewall as an exception and enable the firewall. Disable any anti-virus program, close MotionBLITZ Director2 and restart it. If it works, configure MotionBLITZ Director2 in the anti-virus program settings as an exception and enable the anti-virus program.
Camera performance is very slow	<ul style="list-style-type: none">• Check if the speed of the Gigabit Ethernet network adapter amounts to 1 Gbit/s. Usually the LED in the slot cover of the network card indicates whether the actual transmission speed amounts to 1 Gbit/s. If it is less than 1 Gbit/s, it is too slow. If the network speed is too low, change the settings of the network card to duplex mode.• Contact the Allied Vision Gilching GmbH support team on how to increase the performance of the software.
Timeout in live mode or while recording and Sync in is activated	<ul style="list-style-type: none">• If "Sync in" is activated but no sync-in-signal is provided, no images will be recorded by the camera.• Either deactivate Sync in or deliver a sync-in-signal.

Accelerate frame upload and download

- Frame upload and download can be accelerated by using Jumbo Frames and special settings in the mfggb.ini file. A fast hard disks in combination with a 1 Gbit Ethernet card makes use of Jumbo Frames / Packets. Select "Advanced" in the Properties window of the Windows Device Manager, select "Jumbo" and select the largest packet / frame size possible. *Administrator rights are required.*
- Set the time needed for image export to about 40 MB/s by changing the parameters in the file "mfggb.ini":
 - Exit Director2 software and open mfggb.ini with any ASCII editor in C:\<user-name>\..\AppData\Roaming\MotionBLITZDirector2
 - Change the settings to: RequestMode=1 OutputDataRate=0 OutputInterPacketDelay=0 BlockTransferMode=True GevSCPSPacketSize=0

The MotionBLITZ Director 2 software

5.1 Introduction

5.1.1 Supported cameras

The software supports the following camera series:

- mini cameras

All available functions and camera parameters can be set by the software.

5.1.2 System requirements

Before MotionBLITZ® EoSens® mini2 is used, the Gigabit Ethernet adapter and driver must be installed and updated.

MINIMUM REQUIREMENTS

- Microsoft Windows 7 or newer with the most recent system updates
- Intel Core-i CPU (2nd generation) or comparable CPU of another manufacturer
- 2 GB PC RAM and 128 MB graphics memory
- Display resolution of 1280 x 1024 pixels

RECOMMENDED

- Microsoft Windows 10 or newer with the most recent system updates
- Quad Core CPU
- 8 GB PC RAM and 256 MB graphics memory
- Display resolution of 1920 x 1080 pixels

5.1.3 Installing the software

All needed files are delivered on a storage medium.

Make sure to meet all requirements before using MotionBLITZ cameras with Director2 software.

In multi camera mode we recommend to connect all cameras via a switch with the Ethernet card of the PC.

1. Install the Director2 software from the storage media.
2. Connect the power supply cable first with the camera, then with the main supply.
3. Connect the Gigabit Ethernet interface cable first with the camera and then with the PC.
4. Start the Director2 software (see ["Starting the software" on page 32](#)).
5. Check "Available cameras".

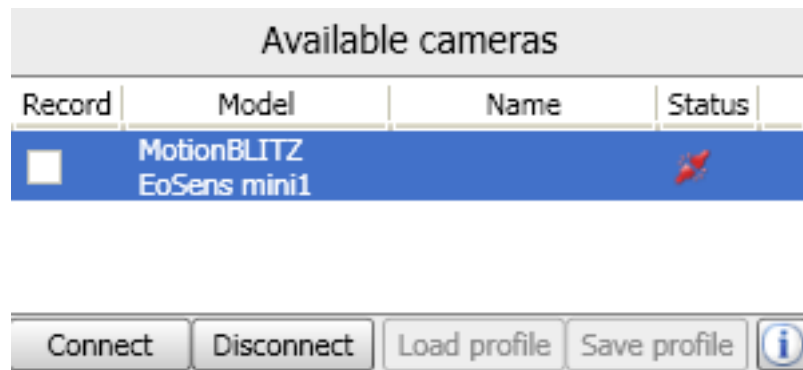

Detected cameras are displayed. This may take a few seconds. At first, the status is red.

6. Select the camera by checking the camera model.
7. Click [Connect] or double click the red status symbol. As soon as the connection to the camera is established, the status symbol turns green.
8. Repeat steps 6 and 7 to install further cameras for simultaneous use.

5.2 The user interface

5.2.1 Starting the software

The user interface helps you to set all parameters of the camera for recording, playback, and saving the frames after recording. Furthermore it allows to edit image sequences that have been stored after recording.

1. Start the software by double clicking the Director2 symbol on the PC desktop or by selecting the application in the windows start menu

2. Select your camera type by clicking on the appropriate entry in the list of „Available cameras“
3. Click [Connect].

5.2.2

The user interface

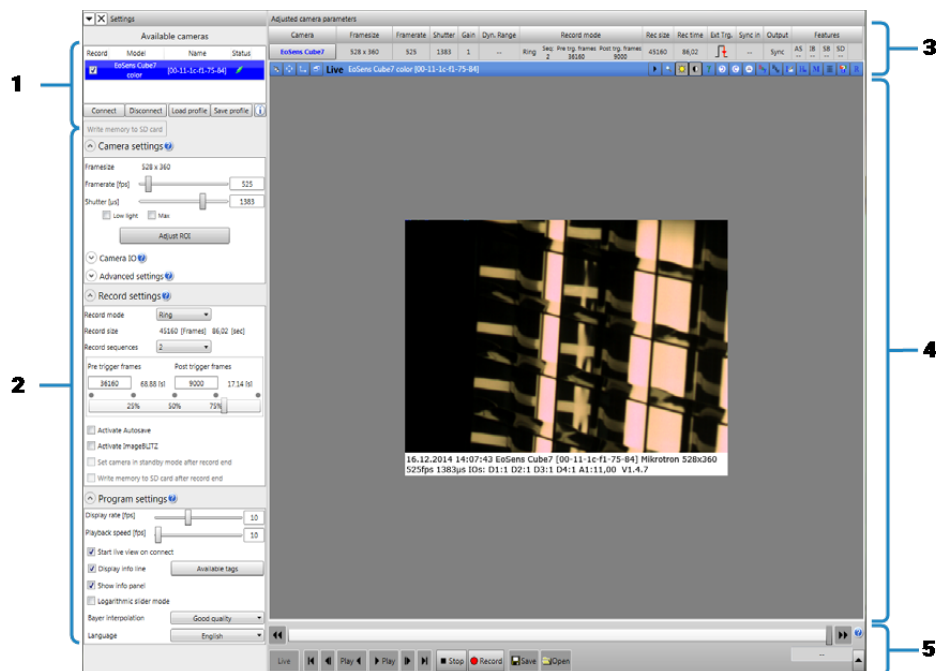

Fig. 5-1: User interface

The user interface consists of the following items:

- Available cameras (1) to connect or disconnect the camera and load and save profiles (see ["Connecting the camera" on page 34](#)).
- Setting panels (2) for the camera, recording, and program settings (see ["Settings" on page 34](#)).
- Info panel (3) displays the settings of the connected camera. The image processing and analysis bar (blue) provides imaging processing functions like zoom, change brightness of the image.
- Display window (4) displays the current frame (see ["Display window" on page 47](#)).
- Recording control bar (5) is context sensitive and provides buttons to start and stop recording, playback and to save or open files. The elements of the recording control bar are described in the section on the Display window.

GENERAL ACTIONS

The following actions apply to all items of the user interface.

- Select operation modes or change parameters by pressing a command button or by selecting an one of the control windows (e.g. camera settings).
- If the mouse cursor is moved slowly over a command button or symbol a tool tip will be displayed.
- On the left side, there is the control panel for the camera and program settings, in the middle the display window and below the panel for controlling the application. Each part may be enlarged or minimized, removed from the dock, and docked again.
- Select operation modes or change parameters by pressing a command button or by selecting an one of the control windows (e.g. camera settings).

5.2.3 Connecting the camera

When starting the application the camera is displayed in the "Available cameras" window.

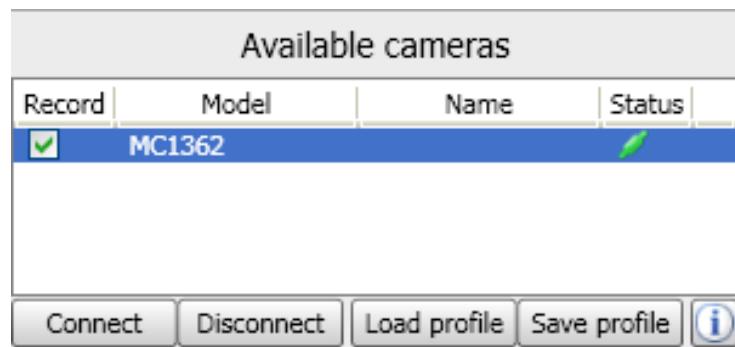

Fig. 5-2: Available cameras

- To connect the camera, double click on the camera or click **Connect**.

5.3 Settings

5.3.1 Overview

The software settings for the camera parameters are defined in the following panels:

- "Camera settings" for the configuration of frame rate, shutter settings and ROI (see ["Camera settings" on page 35](#))
- "Camera IO" for the configuration of input and output signals (see ["Camera IO" on page 38](#))
- "Record settings" for the configuration of the recording mode, recording directory and file handling (see ["Record settings" on page 39](#))

- "Program settings" for settings of the application, such as playback speed and display rate (see "Program settings" on page 43)
- "Advanced settings" for the configuration of black level, digital gain and the dynamic range (see "Advanced settings" on page 46)

The panels are opened by clicking at the corresponding expander controls .

When using more than one camera simultaneously, the settings of the selected camera are displayed.

OPENING THE CONTEXT-SENSITIVE HELP

The settings panels provide a context-sensitive help.

- Click the icon  next to the menu name to open the context-sensitive help.

5.3.2 Camera settings

FRAME RATE AND SHUTTER SETTINGS

The frame rate and exposure time may be adjusted with the slider „Frame rate [fps]“ and „Shutter [μ s]“ or by writing the values into the corresponding input fields.

- When changing the frame rate the maximum shutter value is automatically adjusted.
- The shutter time is set in μ s and depends on the frame rate. The value must not exceed the time needed to record one frame.

All changes will take effect immediately.

Low light mode

In low light mode the camera exposure time is extended to up to 99.9 milliseconds to increase its sensitivity. This mode is used for setting up the frame size and the focus in "Live" mode.

- Select the exposure time with the slider "Shutter [μ s]" or write it directly in the appropriate number field. Low light mode will be automatically finished if a recording is started.

Max

If this check box is activated, the maximal exposure time for the actual frame size and frame rate is be automatically used.

ADJUST THE ROI

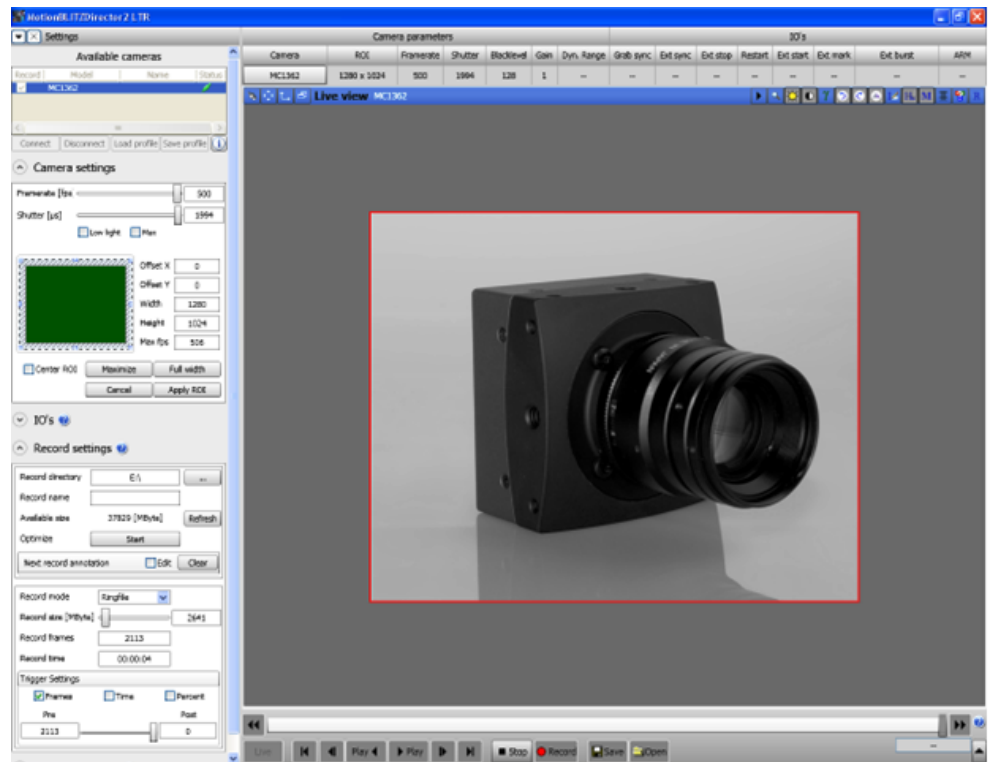

Fig. 5-3: Adjusting the ROI

1. Select **Adjust ROI** to adjust by one of the following options:
 - Writing the values for x-position (Offset X), y-position (Offset Y), width
 - Writing the height directly into the text fields
 - Moving the green box in the settings
 - Moving the red rectangle in the display window
2. Select **Apply ROI**. All settings will be applied to the selected camera.

FIXED FRAME RATE

When setting the ROI in this context a fixed frame rate can be set and changing the frame rate is automatically used to adjust the frame size. The higher the frame rate, the smaller the ROI.

CENTER ROI

1. Select **Center ROI** to center the ROI within the frame. If this box is checked, the ROI cannot be moved manually.
2. Select **Maximize** to cover the full sensor area.
3. Select **Full width** to adjust the width of the ROI to the full sensor width.

GAIN

The gain may be adjusted with the slider „Digital Gain“. Factors 1 to 4 are allowed.

The image quality decreases the more the gain is increased.

IMAGE INFORMATION FIELD

Each recorded frame holds various information in the first line of the image.

Byte	Description
0...1	image counter [1 ... 65535]
2	free, currently not in use
3	time-stamp origin** not used
4...7	high performance counter ticks (HighPart)
8...11	high performance counter ticks (LowPart)
12	digital inputs 0-7; lowest bit IO = 0; highest bit IO = 7
13	used for image markers
14	optional – used for ImageBLITZ®
15	optional – used for ImageBLITZ®
16...19	optional – used for IRIG timestamp (UTC seconds) not used
20...23	optional – used for IRIG (UTC microseconds) not used
24...27	internal
28...31	optional – MDIOS1 data*
32...35	optional – MDIOS2 data*

* The value is saved in the bits 0...21

** Origin of the timestamp data saved in bytes 16...23 (0 = interpolated, 1 = IRIG card)

5.3.3

Camera IO

With panel Camera IO the input and output ports of the camera can be configured to stop recording by an external trigger.

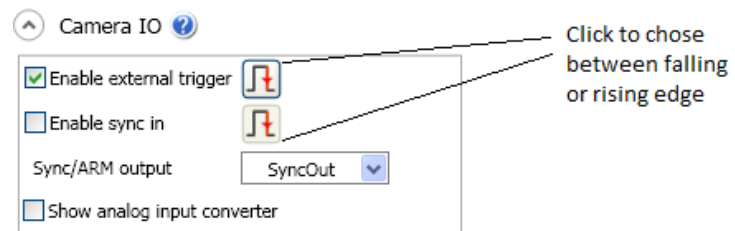



Fig. 5-4: Camera IO

- **Enable external trigger**, see ["Enable external trigger" on page 38](#)
- **Enable sync in**, see ["Enable sync in" on page 38](#)
- **Sync/ARM output** offers two settings. The SyncOUT connector of the camera outputs either a Sync or an ARM signal.
 - If SyncOut is selected, the SyncOUT connector carries a strobe corresponding to the selected exposure time of the camera.
 - If ARM is selected, the SyncOUT connector signals that the camera is ready for triggering in ring mode (circular recording mode). ARM can be active at a high or a low signal.

ENABLE EXTERNAL TRIGGER

This function is used when recording has to be stopped by an external trigger signal. Selects if a rising edge or a falling edge of the signal triggers a recording stop.

Use the adequate connector to connect the Trigger IN input of the camera with the external trigger (refer to the manual of the camera).

1. Select **Enable external trigger**.
2. Click at the trigger  to select whether the rising or falling edge stops the recording.
3. To complete a recording session that has been started with the camera's Trigger button, click **Disconnect** followed by **Connect** in the panel "Available cameras" (see ["Connecting the camera" on page 34](#)).

ENABLE SYNC IN

To synchronize several cameras either use an external clock generator or define one camera as master camera. When using multiple cameras, SyncOut must be configured for one camera whereas for all other cameras SyncIN must be set.

If Sync IN is enabled but no Sync IN signal is provided, the camera will not record any image and timeouts may occur!

1. Select **Enable sync in**.
2. Click at the trigger  to select whether a rising edge or a falling edge of the signal will be used to synchronize the cameras.
3. Use the adequate BNC connector to connect the SyncOut output of the master camera or clock generator with the SyncIN of the slave camera.
4. Select a frame rate for the slave camera.

When synchronizing a slave camera by a master camera, the frame rate of the slave camera has to be at least 2 fps higher than the master camera's frame rate, otherwise the slave camera will not provide the same frame rate as the master camera. As a result frames will be lost.

Example

To set 1000 frames per second, set the master camera to 1000 fps and select 1004 fps for each slave camera.

5.3.4

Record settings

SINGLE MODE

In single mode, the camera stops recording when the internal frame buffer is full. When setting the recording mode to "Single", choose between the following settings:

- Record until end
- Record while trigger is active
- Burst trigger mode.

Record until end

ImageBLITZ will not be available if Record until end is selected.

Recording runs until the selected record size is reached. After this, recording will be stopped automatically.

Alternatively, recording can be stopped by one of the following options:

- Selecting Stop  in the record control bar
- Pressing [F12]
- An external trigger signal
- To abort recording, press [ESC].

By pressing [ESC], all recorded images will be deleted.

Record while trigger is active

As long as the trigger is active, recording will proceed. If the trigger is deactivated before the image buffer is full, the camera will wait for the next trigger. A trigger can either be one of the following items:

- An external trigger signal connected with the camera trigger input, provided that **Enable external trigger** in "Camera IO" has been enabled (see "[Enable external trigger](#)" on page 38)
- The ImageBLITZ trigger (optional) is available

In this mode, the high / low status of the trigger is essential, not the edge. The active edge or the active status of the signal has to be selected in "Camera IO".

Recorded frames will only be displayed while the trigger is active.

Recording stops as soon as:

- The end of the buffer is reached
- **Stop**  in the record control bar is selected
- [F12] is pressed

Burst trigger mode

In Burst trigger mode a preset number of frames will be recorded for each trigger edge. The trigger can be one of the following items:

- An external trigger signal
- ImageBLITZ (optional)

Recorded frames are only displayed while the burst trigger is active.

The number of frames to be recorded can be set between 1 and 1022.

After recording the defined number of frames the camera will wait for the next edge as long as memory storage is available is not reached. If the memory is full, recording will be finished.

- Alternatively, recording can be stopped by one of the following items:
- Selecting **Stop** in the recording control bar
- Pressing [F12]

RING MODE

In ring mode, the camera records frames in circular mode (i.e. the oldest frames will be overwritten by the most recent ones) and waits for a trigger signal to stop. When the selected recording size is reached, the oldest frames will be overwritten by the most recent ones until recording is stopped.

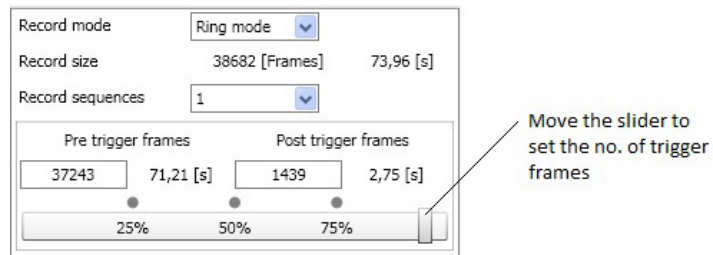

Fig. 5-5: Ring mode

Recording is stopped by one of the following options:

- Clicking **Stop** in the recording control bar
- Pressing [F12]
- External trigger event

The defined pre and post trigger frames will be recorded before recording is stopped.

- To abort recording, press [ESC]. According to the camera type connected and its memory capacity, the maximum number of frames and the time needed to record them are displayed.

By pressing [ESC], all recorded images will be deleted.

TRIGGER SETTINGS

This feature is only available in ring mode and defines the number of frames to be recorded after the trigger is activated.

Recording must be stopped by an external signal or by pressing the F12 key to open the trigger settings. Otherwise recording will be stopped immediately.

ACTIVATE AUTO SAVE

If **Activate Auto save** is enabled, the recorded event will be written automatically to a defined hard disk. After the sequence has been completely written to hard disc, the camera will automatically be rearmed.

File names (Autosave_ DATE_TIME.rec) are assigned automatically.

1. Enable **Activate auto save** to set the following parameters in Single Mode:
 - Export directory used to save the images to file
 - Export format (for fast image download the file format .REC (fast RAW format) is recommended).
2. Enable **Activate Auto save** to set the following parameters in Ring Mode:
 - Number of frames
 - Pre- and Post-trigger frames

- Export directory used to save the images to file
- Export format (for fast image download the file format .REC (fast RAW format) is recommended).

Frames will be saved automatically at the end of a triggered recording. If several sequences are selected, frames will automatically be saved after the last sequence.

Autosave can also be triggered by an internal trigger (e.g. ImageBLITZ) or by pressing [F12]. Each recording will be stored in a different file into the defined export directory.

To view the files, import the images.

If the disk runs out of space, Autosave will automatically be stopped. The available space is displayed in the Record settings window.

RECORD SEQUENCES

Record sequences triggers in multi-sequence mode but is only available when the camera is equipped with the optional MS-option.

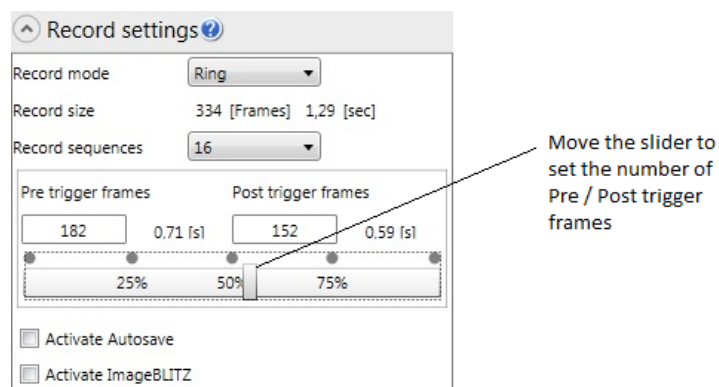

Fig. 5-6: Recording sequences

- Select the sequence settings 1, 2, 4, 8, or 16 in **Record sequences**.

Depending on the sequence settings, the internal memory of the camera can be divided into 1, 2, 4, 8, or 16 equal memory partitions. In each partition a trigger event (external trigger signal or ImageBLITZ trigger) is saved.

If a trigger event occurs, the defined number of post-trigger frames will be recorded. After the trigger event the camera continues with the next sequence and starts recording the pre-trigger frames. The recording proceeds until all sequences have been completed.

If a trigger event occurs before the defined number of pre-trigger frames are recorded, the number of pre-trigger frames will be less than defined, whereas the number of post-trigger frames will be as expected.

Multi-sequence recording

Multi-sequence mode is a software feature. It is not possible to start a multi-sequence recording session if the camera is not connected. If a multi-sequence recording is stopped, the active sequence will be completed.



Fig. 5-7: Multi-sequence recording

In multi-sequence mode, the active sequence is displayed live at the top of the display window during recording.

After the recording session is complete, the numbered sequence command buttons are displayed in the bottom control bar.

- Click on one of the sequence command buttons (0 to 15) to display the frame recorded after the trigger event in the current sequence.
- Double click on the sequence button to select the current sequence. Depending to the camera type connected and its memory size, the maximum number of frames and the time needed to record them are displayed.

5.3.5

Program settings

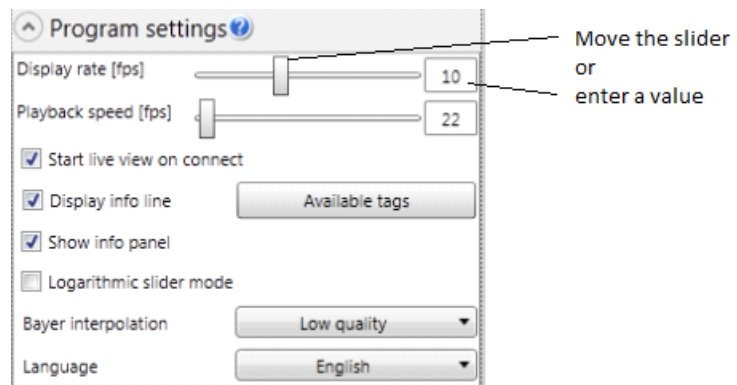

Fig. 5-8: Program settings

- **Display rate [fps]:** to reduce the CPU load in slow systems, the display rate during live view can be decreased (1 to 25 fps). The maximally possible display rate depends on the hardware used (CPU, graphics card).
- **Playback speed [fps]:** The playback speed can be set from 1 to 1000 fps for an opened image sequence. During playback not every frame will be displayed, some frames will be skipped.
- **Start live view on connect** sets the camera automatically into live mode as soon as a camera is connected.
- **Display info line** appends additional information to the bottom of each frame. The info line can contain various camera and record parameters, e.g.: frame rate, shutter time, IRIG time stamp (optional feature).

2/16/2011 2:03:42 PM MC1362 1280x1024 500fps 1994µs

- **Show info panel** displays the camera parameters at the top of the Display window. It contains information about the current camera settings, trigger settings, or recording.

Camera parameters																
Camera	ROI	Framerate	Shutter	Gain	Dyn.Range	Rec Mode			Rec size	Rec time	Ext.Trig.	Sync in	Output	AS	IB	PR
EsSens mini1	1280 x 1024	506	432	1	--	Ring	Seq: 1	Pre: 1636	Post: 0	1636	3,23		--	Sync	--	--

- **Logarithmic slider mode** uses a logarithmic scale for the shutter slider and the playback speed slider in order to adjust shutter speed more naturally. *The higher the image quality, the longer the computation time. In slow systems it is recommended to use the lowest quality in order to achieve a higher display rate.*
- **Bayer interpolation**, see "[Bayer interpolation](#)" on page 44
- **Language** adjusts the language of the interface.
 - After selecting a language, restart Director2 for the changes to be applied.
 - To add languages, edit the language files. *The language files are located in the directory Program Files -> Allied Vision Gilching GmbH -> camera directory-> Languages.*

BAYER INTERPOLATION

Three different qualities of the BAYER to RGB colour rendering are available. This feature is active for color cameras and BAYER image data only. During recording the lowest quality is automatically used to improve performance.

This feature is only available for color cameras.

Depending on your settings the following algorithm will be applied:

	Low quality	Good quality	High quality
Algorithm	Nearest Neighbor	Edge Sensing	Laplacian
Mask/ Filter Kernel	2 x 2	3 x 3	5 x 5
Comment	Green values will be averaged	Horizontal and vertical edges will be taken into account	Horizontal, vertical and diagonal edges will be taken into account

The higher the image quality, the longer the computation time. In slow systems it is recommended to use the lowest quality in order to achieve a higher display rate.

- Nearest Neighbor is the fastest algorithm but delivers the lowest image quality.
- Laplacian is the slowest algorithm but delivers the highest possible image quality.

EXAMPLE

The examples below show the difference between the quality levels.

- Low quality

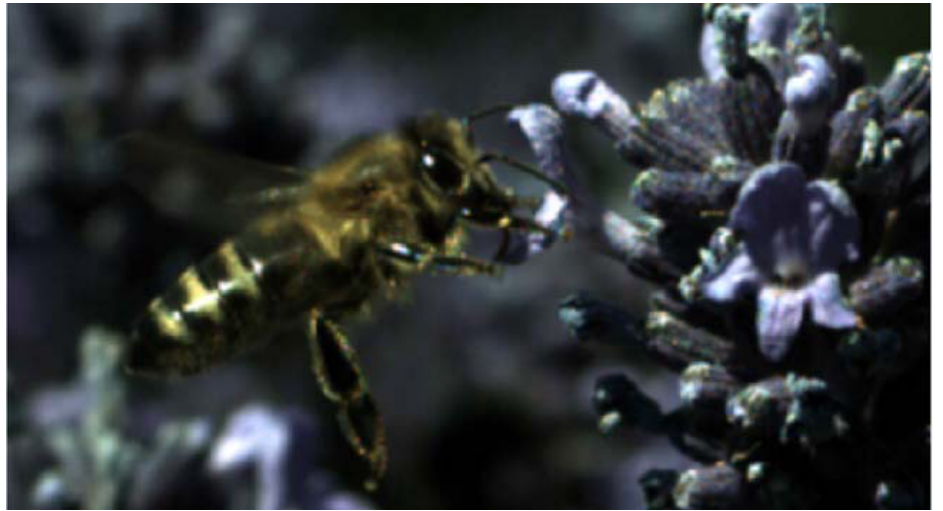

- Good quality



- High quality



5.3.6 Advanced settings

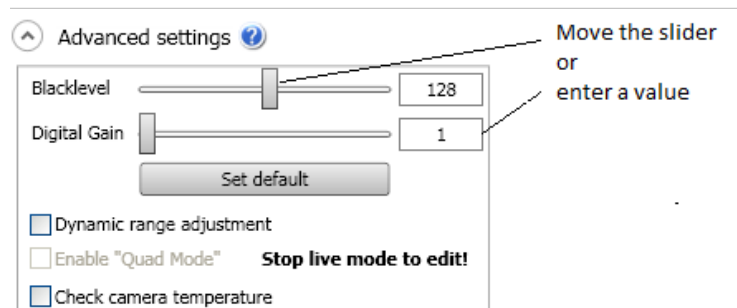

Fig. 5-9: Advanced settings

- **Black level**, see "[Black level](#)" on page 46
- **Digital Gain** increases the brightness of the frame. *The quality of the image decreases when increasing the gain. Increasing the gain, the sensitivity of the camera increases but noise increases, too.*
 - Select **Set default** to reset the default parameters.
- **Dynamic range adjustment**, see "[Dynamic range adjustment](#)"
- **Check camera temperature**, see "[Check camera temperature](#)" on page 47

BLACK LEVEL

Black level defines the brightness at the darkest part in the image. The base black level value can be set from 0 to 200. If the setting is correct, the sensor will deliver the pixel value 0 for a completely black image.

- If the value is too high, the sensor will deliver a pixel value above 0, which means gray.
 - If the value is too low, the sensor will deliver a pixel value 0 (totally black) for images that are gray.
1. In live mode, close the lens of the camera. This will produce a completely black image.
 2. Select **Histogram Control**.
 3. Enable Histogram Mode.
 4. Select **Set default**.
 5. Set Type to "Luminance".
 6. Adjust the black level until the black line in the Luminance selection touches the line "0" of the diagram.

CHECK CAMERA TEMPERATURE

1. Select "Check camera temperature" to enable measuring the internal camera temperature every minute.

If the temperature is in normal range, the temperature status will be indicated by a green "°C" in the Camera settings panel header.



If the temperature is too high, the green icon will turn red. In this case the camera has to be cooled in order to avoid quality loss or damages to the camera.

5.4 Display window

5.4.1 Display window icons

All changes in the display window are saved except for RAW Formats.

The top line of the display window offers several toggle buttons. They can be used to organize the screen and provide image processing functions. In addition, the name of the currently displayed file is shown in the windows title.

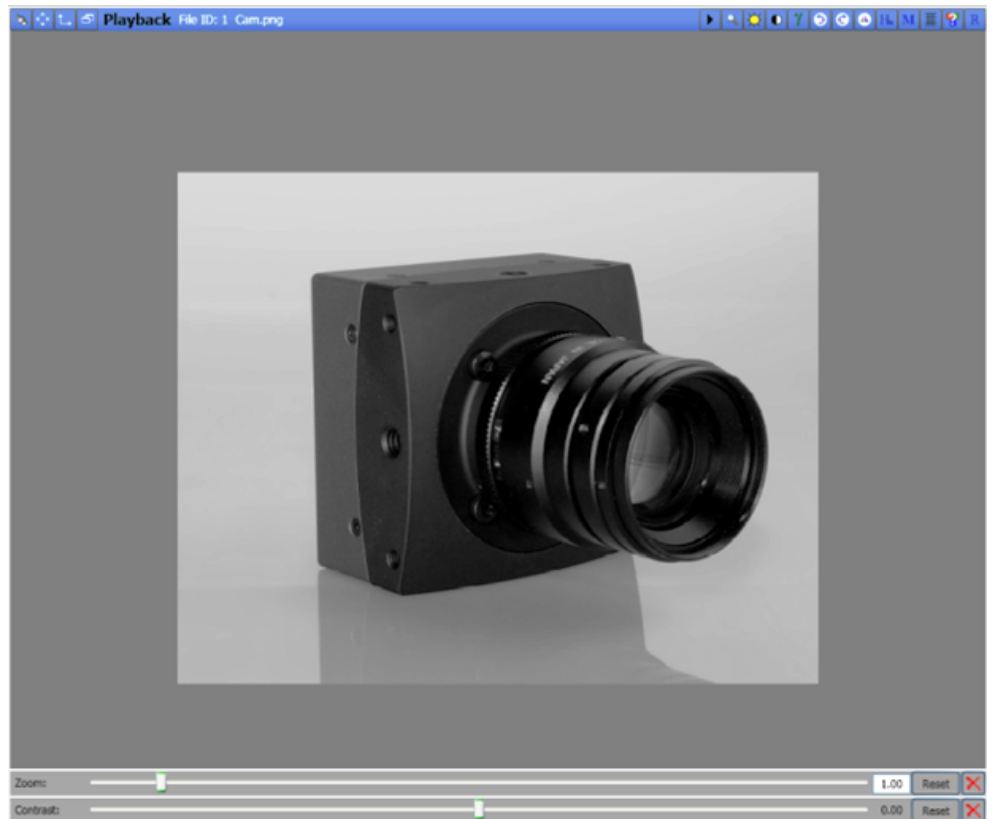





















Fig. 5-10: Display window

ICONS

Icon	Name	Meaning
	Dock and undock the display window	Depending on the current position of the window it is docked or undocked. In undocked state, the window can be moved and re-sized. In docked state the window is fixed.
	Display original size	Displays the image in its original size.
	Fit to window	Fits the image to window if the image is larger than the display area.
	Minimize / maximize the window	Depending on the current state of the window, it is maximized or minimized.
	Show / hide the toolbar	Depending on the current state the toolbar, it is shown or hidden. <i>In a minimized display window the toolbar is always hidden.</i>

Icon	Name	Meaning
	Zoom	<p>The image can be zoomed by the mouse wheel or by clicking the zoom button in the toolbar. When the button in the toolbar is clicked a control panel appears at the bottom of the window.</p> <ul style="list-style-type: none"> To reset the zoom, click on the mouse wheel when hovering over the image.
	Change brightness	Changes the brightness of the displayed image. The control panel appears at the bottom of the display window.
	Change contrast	Changes the contrast of the displayed image. The control panel appears at the bottom of the window.
	Gamma correction	To exponentially adapt the percentage brightness of the image you can use the gamma correction (see " Gamma correction panel " on page 50).
	Image rotation	Rotates the displayed image clock or anti-clockwise. The rotation is done in 90 degrees steps.
	Image flip	Flips the displayed image horizontally or vertically.
	Bayer adjustment	Invokes the Bayer adjustment for color cameras (see " Bayer adjustment (white balance) " on page 51).
	Display RAW image data	<p>Displays the RAW image data. Raw images are always shown as a gray color images because Bayer correction has not been executed.</p> <p><i>Display RAW image data is only available for color cameras. If enabled only the RAW image data is stored even when a non-RAW export format is selected.</i></p>
	Edit the info line	Opens a text field to add arbitrary text to the info line at the bottom of the image.
	Show histogram	Shows the histogram of the currently displayed image (see " Histogram " on page 52).

Icon	Name	Meaning
	Add image marker	Adds arbitrary markers to the image. The markers can be adjusted and moved with the mouse. Markers are used for tagging the position of an interesting part in the displayed sequence.
	Show grid lines	Displays a grid upon the image. The width and height of the grid can be freely adjusted.
	View RGB values	Shows the RGB values at the current mouse position. The values are displayed at the bottom of the display window.
	Revert changes	All settings are reset to its default state. <i>White balance settings are not affected.</i>

5.4.2

Gamma correction panel

The gamma correction panel is shown at the bottom of the window.

- A gamma value of 1 leaves the brightness unchanged.
- Values greater than 1 let dark parts become brighter.
- Values smaller than 1 let bright parts become darker.

GAMMA CORRECTION SAMPLES

- Gamma = 0.6: image becomes darker



- Gamma = 1.0: image remains unchanged



- Gamma = 2.0: image becomes brighter



5.4.3

Bayer adjustment (white balance)

Bayer adjustment is only available for color cameras.

Good illumination is extremely important for an optimal true colour display. Best results are achieved by using daylight or halogen light. In order to recalibrate the colour correction:

1. Start the live view of the camera.
2. Click "white balance".

The control panel at the bottom of the display window allows to adjust the white balance.

ADJUST WHITE BALANCE MANUALLY

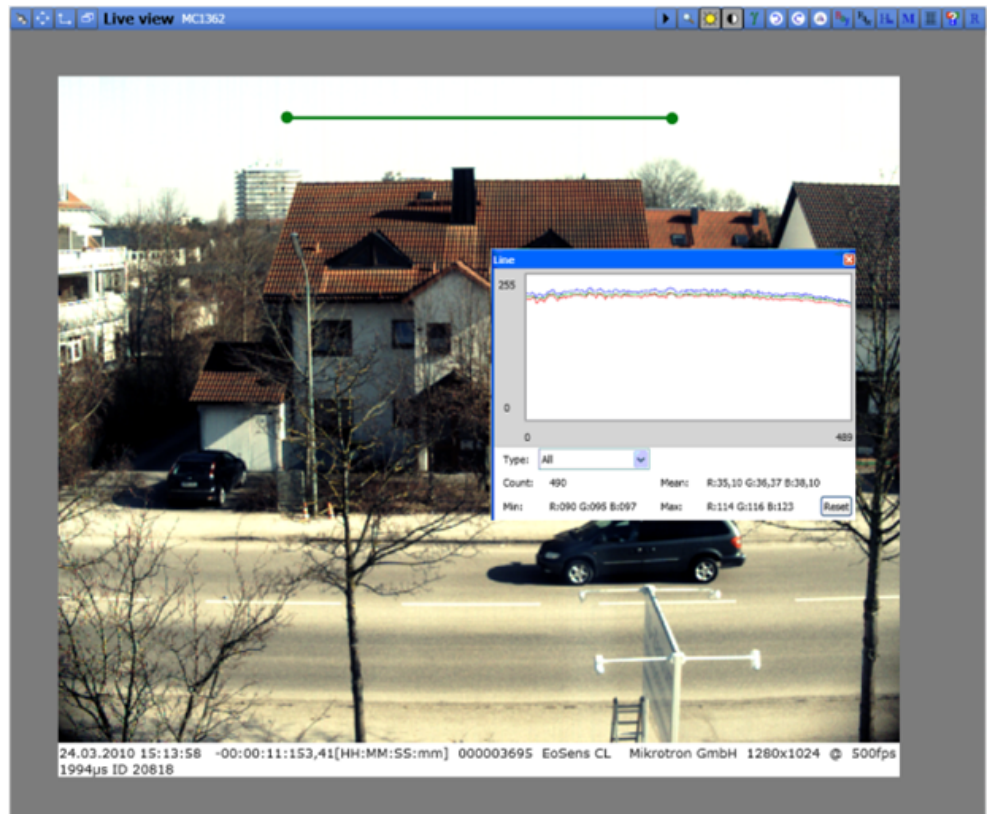

Fig. 5-11: Adjusting white balance manually

- To adjust the white balance manually, use the histogram window in line mode. Adjust the size of the green check line, which is automatically displayed in the camera image when the histogram window is opened.
- Use the mouse to move this line over a white area. (Click and hold on the line and move it). The values of the pixels along this line will be shown as three curves – red, green and blue.
- Using the "R", "G" and "B"-sliders, move the three curves until they are nearly congruent as shown in the figure above.

ADJUST WHITE BALANCE AUTOMATICALLY

- Take a picture of a scene that contains an area in the center, which is mostly white.
- Select **Auto WB** in the bottom control bar to adjust white balance automatically.

The line for manual balancing is not used for auto white balancing.

HISTOGRAM

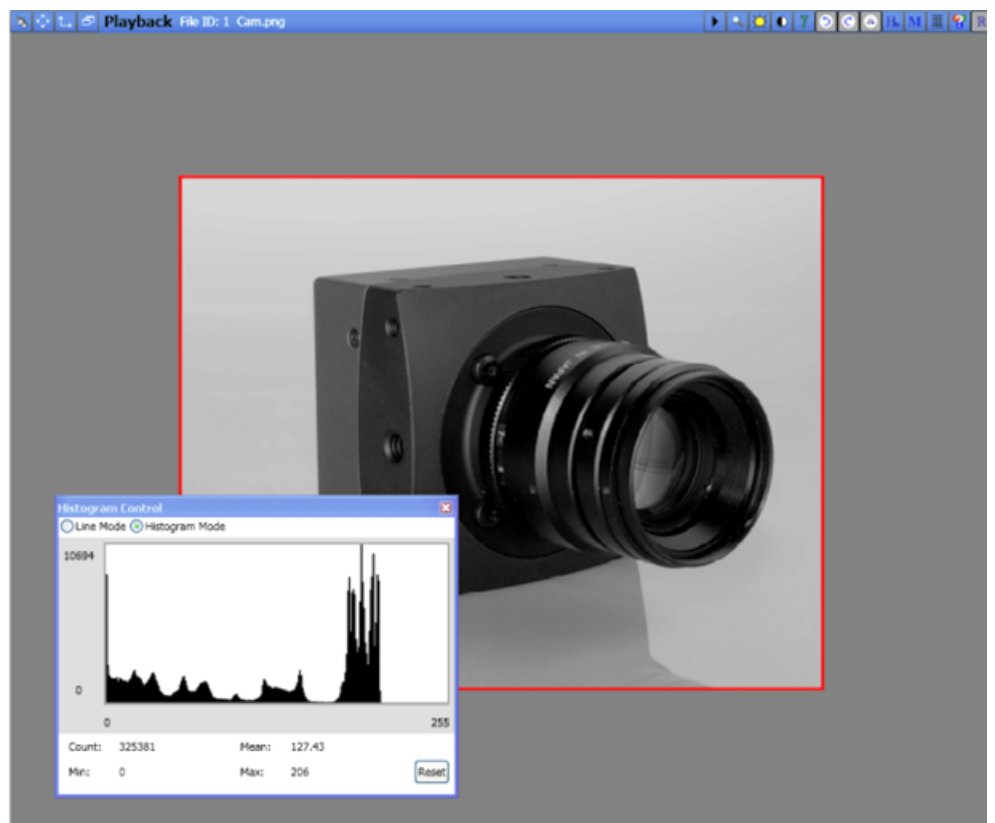

Fig. 5-12: Histogram

The area to be computed in the histogram can be defined by moving the red rectangle. Two modes are available:

- Line mode that shows all pixels on the selected line and
- Histogram mode

5.4.4

Open images

- Select **Open** in the recording control bar to select the images. The file information about the actually displayed sequence is shown in the info panel.

If a stack of single images is imported, all of them must have the same width and height. Otherwise they will not be displayed correctly.

The following file formats can be imported:

- REC (proprietary format),
- BMP
- TIFF
- JPG
- PNG

OPEN MULTIPLE FILES SIDE BY SIDE

LTR .dat files are synchronized to their trigger frame. All other file types are synchronized frame by frame.



Fig. 5-13: Multiple files side by side

Allows to open and to view up to 4 recorded sequences side by side. Since the files are streamed from HD a fast harddisc is required to view the streams fluently. To increase the performance during playback each playback stream can be disabled. Only the selected master file is used for image export.

To adjust multiple sequences an offset can be set for each sequence.

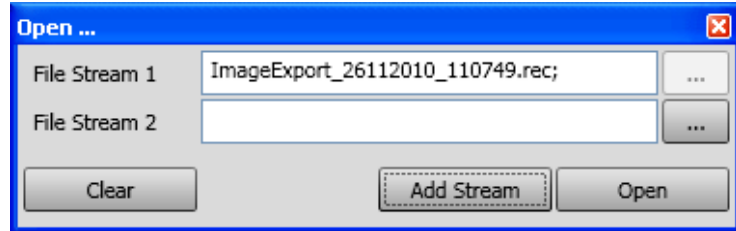

SYNC RECORD FILES

After checking the “sync record” box all sequences are synchronized to their trigger frame and cut. Afterwards, each sequence contains the same number of frames before and after the trigger. This mode assumes that all sequences were recorded with the same frame rate and stopped by a common signal.

All sequences can be exported at once.

5.4.5

Image export

The following formats are supported:

Format	Description
BMP	Images are stored uncompressed as BMP.
JPG	Images are stored in JPG format with the selected compression quality.
PNG	Portable Network Graphics (PNG) is a bitmapped image format that employs lossless data compression.
TIFF	Images are stored in TIFF format (Tagged Image File Format). Choose between non-compressed, LZW (Lempel-Ziv-Welch-Algorithm) and lossless compression.
DNG (RAW format)	Images are stored in Adobe DNG (Adobe Digital Negative) format. DNG is an open RAW format which can be directly imported into Adobe Photoshop to post process the data. Many other image processing tools also support DNG since it is a common file format for raw camera data.
AVI	Images are stored in the AVI container format. The AVI format allows compressed (Divx) or uncompressed storage.
DAT	proprietary container format

IMAGE EXPORT DIALOG

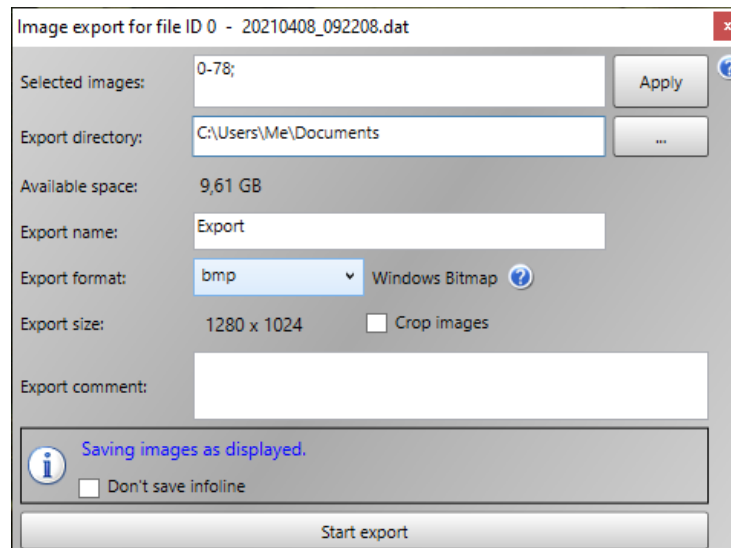
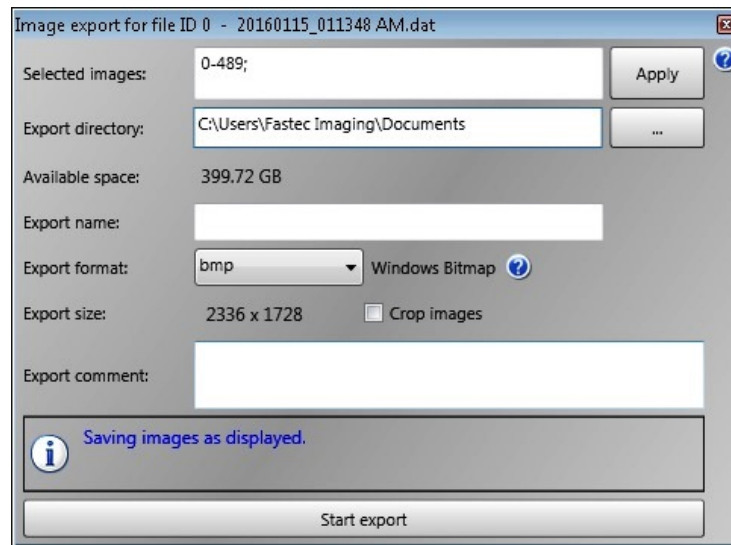

Fig. 5-14: Image export dialog

The image export dialog is opened by clicking **Save** in the bottom control.

EXPORT SIZE

The selected area is applied to the whole image sequence.

Images can be cropped before export.

The [Crop image] button displays a rectangle on the image. By moving the rectangle the export area is defined.

EXPORT COMMENT

A comment can be attached in order to describe the export sequence. If supported by the export format, the comment will be written into the file header. Otherwise it will be written into the additional export file (see ["Additional export file" on page 56](#)).

ADDITIONAL EXPORT FILE

During image export an additional file written into the export folder. Its file extension is *.exp. This file provides additional information about the recording and can be used to import the images all at once. The structure of the file is shown below.

```
[COMMENT]
Comment=No comment entered.
RecordAnnotation=No comment entered.
[EXPORTINFO]
Type=bmp
[CAMERA]
Manufacturer=Allied Vision Gilching GmbH
Model=EoSens® CL
Frame rate=500
Shuttertime=1994
Serial=00146
Firmware=B3.01-F2.96-V4.31
[RECORD]
StartTime=Unknown
ImageCount=11
[IMAGEDescription]
ImageWidth=1280
ImageHeight=1024
ImageFormat=COLOR_RGB32
[SEQUENCEINFORMATION]
NumberOfFrames_00=6
TriggerFrameNumber_00=39
TriggerRefTime_00=1170,0192
NumberOfFrames_01=5
TriggerFrameNumber_01=20
TriggerRefTime_01=1170,0192
[EXPORTEDIMAGES]
```

5.5 Recording

5.5.1 Overview

After configuring the parameters, the settings are checked by using "live mode".

In live mode, a single frame is recorded, displayed, and will be overwritten by the next frame. This mode can be used to define image details, adjust the focus, and for setting up various camera parameters.

- Click **Live** in the record control bar.

If the camera is ready for recording, two different recording modes are available:

- Ring mode: camera records frames continuously (i.e. the oldest frames will be overwritten by the most recent ones) and waits for a signal to stop
- Single mode: the camera stops recording when the internal frame buffer is full

The primary difference between single mode and ring mode is the usage of the camera image memory and trigger.

5.5.2 Start recording

Recording is started by one of the following actions:

- Pressing [F5]
- Clicking **Record** in the record control bar

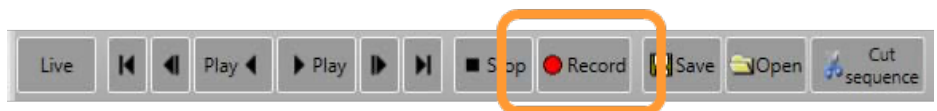

If recording is started by pressing the trigger button, reconnect by clicking **Disconnect**, followed by **Connect** in "Available cameras" after the recording sequence is complete. This saves the chronology of the pictures.

5.5.3 Stop recording

Recording is stopped by one of the following actions:

- Clicking **Stop** in the record control bar
- Applying a trigger signal to the appropriate camera input connector
- Changing the image within the ImageBLITZ area

Depending on the post trigger selected, it might take a while until recording stops. The sequence is complete after all post-trigger frames have been recorded.

5.5.4 Playback

To access the recorded frames, the camera must be connected.

1. Connect the camera with the PC via Gigabit Ethernet.
2. Wait until the camera is displayed in "Available cameras".
3. Click **Connect** and wait until the status is green.
If a recorded sequence is available, it is loaded automatically.

Use the play buttons to play the recorded frames forward or backward. To play back recorded files, you have to open the directory and select the file.



Use the buttons to start playback.

1. To change the playback speed, select "Program settings" on page 43.
2. To browse from one picture to another, use the arrow keys or the scroll bar.

If at least two sequences have been recorded a bar with numbered buttons is displayed below the scroll bar.

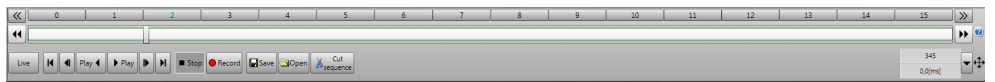

The number of the currently displayed image along with the time-stamp relative to the trigger frame is displayed in the right corner at the bottom.

To jump directly to the trigger frame (frame after the trigger occurred) use the **Jump to trigger**.



The line with the buttons changes, depending on the mode selected. The next record control line shows the buttons displayed when ring mode and 2 sequences are selected.

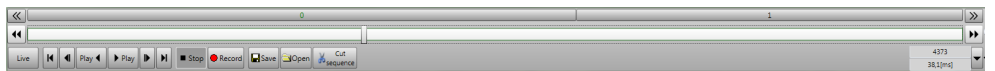

5.5.5

Select a sequence

It takes some time to save or playback all recorded frames. Selecting certain sequences can shorten this process.

Sequences can be selected arbitrarily as shown in the picture below.



1. Move the scroll bar knob to the frame the sequence should start
2. Click **Cut sequence** or press C on the keyboard.
3. Scroll to the frame the sequence should end.
4. Click **Cut sequence** again or press C on the keyboard.

5.5.6 Remove a sequence

1. To remove a selected sequence, move the scroll bar to the sequence.
2. Click **Sequence options**.
3. Select **Remove selection** or **Remove all selections**.

5.5.7 Save a sequence

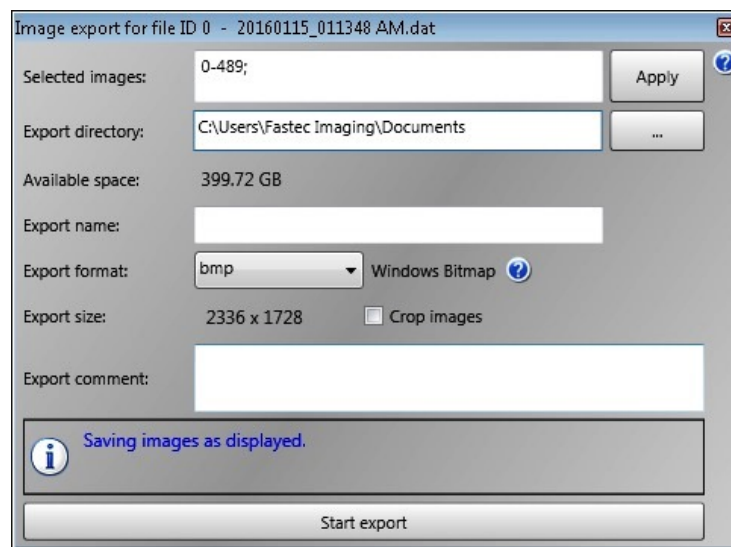
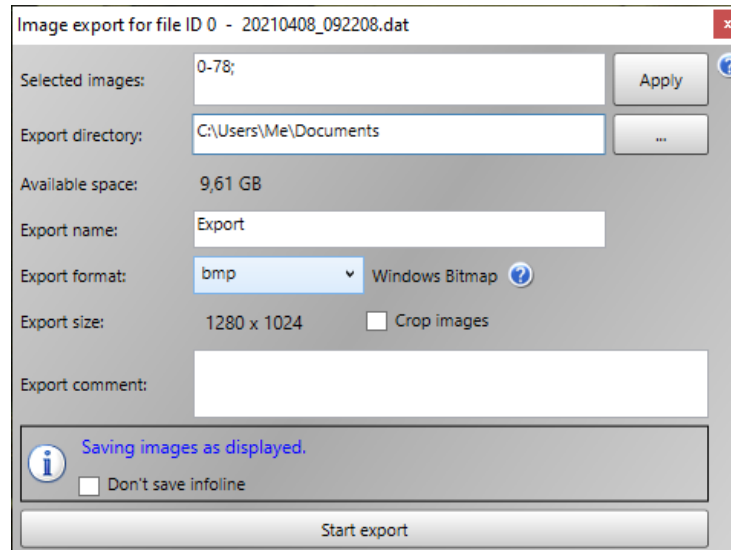

Fig. 5-15: Save a sequence

1. To save or export a sequence, click **Save** in the record control line.
2. Make all settings in the image export window, such as selecting the export directory, the exported file name and selecting the export format.
3. Add a comment to the exported file.
4. Click **Start export**.

SELECT IMAGES

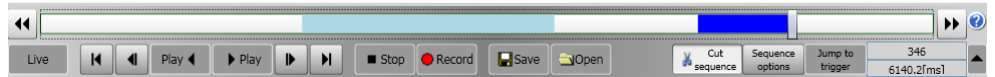

Fig. 5-16: Select images

Sequences can be selected arbitrarily. Images can either be selected by the cutting procedure or manually.

1. To select images manually, enter the range of image numbers to be exported. Values are separated by a semicolon e.g. 10-100;200-300
2. To select images by the cutting procedure select them in the scrollbar.
3. Click **Cut sequence** or press C on the keyboard.
4. Move the scroll bar knob to the frame the sequence should start.
5. Click **Cut sequence** or press C on the keyboard.
6. Scroll to the frame the sequence should end.
7. Click **Cut sequence** again or press C on the keyboard.

5.5.8

Export directory

For each export a unique folder (EXPORTNAME_DATE_TIME) is created in the selected export directory.

With each image export a file with the extension .exp is written into the export folder. The structure of the file looks as follows:

<p>[COMMENT] Comment=No comment entered.</p> <p>[EXPORTINFO] Type=bmp</p> <p>[CAMERA] Manufacturer=Allied Vision Gilching GmbH Model= MotionBLITZ EoSens Cube6 color Frame rate=500 Shuttertime=1 994 Serial= 00146 Firmware= B3.01-F2.96-V4.31</p> <p>[RECORD] StartTime=Unknown ImageCount=11</p>	<p>[IMAGEDESCRIPTION] ImageWidth=1280 ImageHeight=1024 ImageFormat=COLOR_RGB32</p> <p>[SEQUENCEINFORMATION] NumberOfFrames_00=6 TriggerFrameNumber_00=39 TriggerRefTime_00=1170,0192 NumberOfFrames_01=5 TriggerFrameNumber_01=20 TriggerRefTime_01=1170,0192</p> <p>[EXPORTEDIMAGES]</p>
---	--

ImageCount=	indicates the total number of exported frames
NumberOfFrames_00=	indicates the number of exported frames of the first selected sequence
NumberOfFrames_01=	indicates the number of exported frames of the secondly selected sequence and so on
TriggerFrameNumber_00	indicates the position of the trigger frame within the exported sequence

5.5.9

Available space

Displays how much space is available in the selected export directory.

5.5.10

Export name

The export file naming convention for the proprietary container format is:

- EXPORTNAME_SOURCE_RECORD_DATE_EXPORT_DATE.

Single image formats will be named:

- EXPORTNAME_IMAGENUMBER

5.6 Multi-camera mode

5.6.1 Overview

Up to four Cube and mini cameras are supported in MultiCam mode. Each camera can be set up independently. The info panel below displays in short the current settings of each camera.

MultiCam mode does not support multi-Sequence recording. If more than one sequence is recorded, the first available sequence will be used.

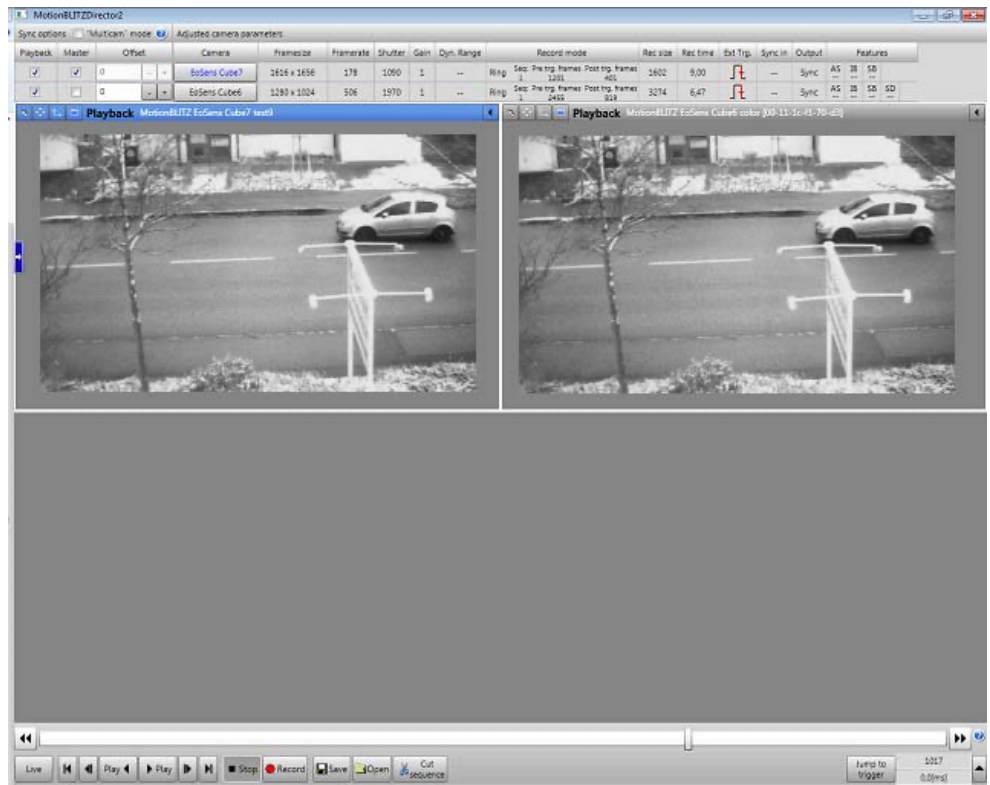

Fig. 5-17: MultiCam mode

- To increase space for the displayed windows, close the left setting area by clicking [X] in the left corner.

To display the recorded sequences synchronously, all recordings must be stopped by a common trigger signal and all cameras should have equal settings for recording mode.

The frame rate of the slave camera must be at least 2 fps higher than the master camera frame rate, otherwise the slave camera will not provide the same frame rate as the master camera and frames will be lost.

5.6.2 MultiCam playback

When multi-camera recording is finished, the sequences are synchronized relative to the trigger frame. The camera that has been enabled as master camera in the info panel synchronizes the other cameras.

By scrolling through the recorded frames the other displays are updated if a frame is available. This mode allows setting an image offset (info panel) to a displayed stream.

For performance reasons each display window can be enabled or disabled during playback.

EXAMPLE

Camera 1 is selected as master camera.

	Recorded frames	Trigger frame	Frames before trigger	Frames after trigger
Cam 1	300	100	99	200
Cam 2	200	150	149	50

- If frame 100 (Trigger frame) of Cam1 is selected, frame 150 of Cam 2 is displayed.
- If frame 105 (5 frames after trigger) of Cam 1 is selected, frame 155 of Cam 2 is displayed.
- If frame 160 (60 frames after trigger) of Cam 1 is selected, frame 200 of Cam 2 is displayed, since frame 210 is not available.

5.6.3 Save a MultiCam sequence

In MultiCam mode all sequences are exported one after another. Each exported sequence is written in a directory of its own.

Only the frames of the camera selected as master in the info panel are exported.

5.6.4 Open a MultiCam sequence

1. To import a previously exported MultiCam sequence, select the corresponding .exp file with the right mouse button.
2. In the context menu, select **Open with**.
3. Select Director 2.

Technical data

For technical data sheets visit [Documents and downloads - Technical documentation](#).

Search for a specific camera, using series and model name or by using the Allied Vision camera selector. The details and download section provides you with manuals, drawings, and certificates.

6.1 Power connector

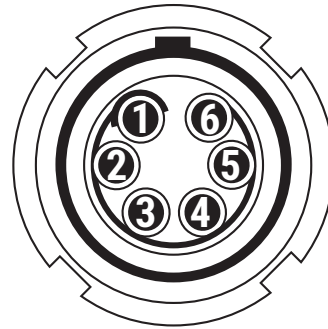

Fig. 6-1: Pinning of matching power plug (solder side)

Pin no.	Signal level	Description
1	Power	GND
2	Power	+10.5 to 30 V
3	Opto in	Sync
4	Opto in	Trigger
5	Opto (The optocoupler of the camera will switch as soon as the input is connected with opto GND.)	GND
6	Opto out	STRB / ARM



Allied Vision Gilching GmbH

Ferdinand-Porsche-Str. 3

82205 Gilching

Phone: +49 8105 3987-60

www.alliedvision.com

info@alliedvision.com

© January, 2026